

Roto Patio Inowa

Intelligent hardware

for tightly sealed sliding systems



Installation, maintenance and operation instructions
for timber and PVC profiles



Contact

Roto Frank
Fenster- und Türtechnologie GmbH

Wilhelm-Frank-Platz 1
70771 Leinfelden-Echterdingen
Germany
Phone +49 711 7598 0
Fax +49 711 7598 253
info@roto-frank.com
www.roto-frank.com

| | | |
|---|---|--|
|  | <p>1</p> <p>1.1</p> <p>1.2</p> <p>1.3</p> <p>1.4</p> <p>1.5</p> <p>1.6</p> <p>1.7</p> <p>1.8</p> <p>1.9</p> <p>1.10</p> <p>1.11</p> | <p>General information..... 10</p> <p>Version history..... 10</p> <p>Instructions..... 12</p> <p>Symbols..... 13</p> <p>Pictographs..... 14</p> <p>Product features..... 15</p> <p>Abbreviations..... 16</p> <p>Target groups..... 16</p> <p>Target groups' obligation to give instructions..... 17</p> <p>Copyright protection..... 18</p> <p>Limitation of liability..... 18</p> <p>Preserving the surface finish..... 19</p> |
|  | <p>2</p> <p>2.1</p> <p>2.2</p> <p>2.3</p> <p>2.3.1</p> <p>2.3.2</p> <p>2.4</p> <p>2.4.1</p> <p>2.5</p> <p>2.5.1</p> <p>2.5.2</p> <p>2.5.3</p> <p>2.6</p> | <p>Security..... 20</p> <p>Presentation and structure of warning instructions..... 20</p> <p>Security levels of warning instructions..... 20</p> <p>Stipulated use..... 20</p> <p>Misuse..... 21</p> <p>Usage restriction..... 21</p> <p>Stipulated use for end users..... 21</p> <p>Misuse..... 22</p> <p>Basic safety information..... 22</p> <p>Installation..... 22</p> <p>Use..... 23</p> <p>Ambient conditions..... 24</p> <p>Operation..... 24</p> |
|  | <p>3</p> <p>3.1</p> <p>3.2</p> <p>3.3</p> <p>3.3.1</p> <p>3.4</p> <p>3.4.1</p> | <p>Information on the product..... 26</p> <p>General hardware characteristics..... 26</p> <p>Application ranges..... 26</p> <p>Application diagrams..... 27</p> <p>200 kg..... 27</p> <p>Design variants..... 29</p> <p>Overview..... 29</p> |

| | | |
|-----|---|----|
| 3.5 | Hardware groove dimensions..... | 29 |
| 3.6 | Dimensions of the roller track..... | 30 |
| 3.7 | Dimensions of the tilt protection device..... | 30 |
| 3.8 | Component dimensions..... | 30 |



| | | |
|----------|--|-----------|
| 4 | Hardware overviews..... | 32 |
| 4.1 | Timber..... | 34 |
| 4.1.1 | Diagram A, K..... | 34 |
| 4.1.2 | Diagram A', K'..... | 38 |
| 4.1.3 | Diagram C..... | 42 |
| 4.1.4 | Diagram C'..... | 48 |
| 4.2 | PVC..... | 54 |
| 4.2.1 | aluplast smart-slide..... | 54 |
| 4.2.1.1 | Diagram A, K..... | 54 |
| 4.2.1.2 | Diagram A – RC 2 / RC 2 N..... | 58 |
| 4.2.1.3 | Diagram C..... | 62 |
| 4.2.2 | aluplast smart-slide neo..... | 66 |
| 4.2.2.1 | Diagram A, K..... | 66 |
| 4.2.2.2 | Diagram A – RC 2 / RC 2 N..... | 70 |
| 4.2.2.3 | Diagram C..... | 74 |
| 4.2.3 | GEALAN SMOOVIO..... | 78 |
| 4.2.3.1 | Diagram A..... | 78 |
| 4.2.3.2 | Diagram A – RC 2 / RC 2 N..... | 82 |
| 4.2.3.3 | Diagram C..... | 86 |
| 4.2.4 | Rehau Synego Slide..... | 90 |
| 4.2.4.1 | Diagram A..... | 90 |
| 4.2.4.2 | Diagram A – RC 2 / RC 2 N..... | 94 |
| 4.2.5 | Salamander evolutionDrive Plus+..... | 98 |
| 4.2.5.1 | Diagram A..... | 98 |
| 4.2.5.2 | Diagram A – RC 2 / RC 2 N..... | 102 |
| 4.2.5.3 | Diagram C..... | 106 |
| 4.2.6 | Schüco LivIng move..... | 112 |
| 4.2.6.1 | Diagram A..... | 112 |



| | | |
|---------|--------------------------------|-----|
| 4.2.6.2 | Diagram A – RC 2 / RC 2 N..... | 116 |
| 4.2.6.3 | Diagram C..... | 120 |
| 4.2.7 | ASAŞ Inova..... | 126 |
| 4.2.7.1 | Diagram A, K..... | 126 |
| 4.2.7.2 | Diagram A – RC 2 / RC 2 N..... | 130 |
| 4.2.7.3 | Diagram C..... | 134 |
| 4.2.8 | Decco 83 and 99..... | 138 |
| 4.2.8.1 | Diagram A..... | 138 |
| 4.2.8.2 | Diagram A – RC 2 / RC 2 N..... | 142 |



| | | |
|----------|------------------------------------|------------|
| 5 | Espagnolettes..... | 146 |
| 5.1 | VT espagnolette..... | 146 |
| 5.1.1 | Backset 25, 30, 35, 40, 50 mm..... | 146 |



| | | |
|----------|---------------------------------|------------|
| 6 | Jigs / tools..... | 149 |
| 6.1 | Drilling jigs..... | 149 |
| 6.1.1 | Roller unit / control unit..... | 149 |
| 6.1.2 | Centre closer..... | 149 |
| 6.1.3 | Strikers..... | 151 |
| 6.1.4 | Marker..... | 153 |
| 6.1.5 | Drilling aid..... | 153 |
| 6.1.6 | Tilt protection device..... | 153 |
| 6.2 | Positioning jigs..... | 154 |
| 6.2.1 | Activator..... | 154 |
| 6.2.2 | Stopper..... | 154 |
| 6.3 | Tools..... | 154 |
| 6.3.1 | Hex keys..... | 154 |
| 6.3.2 | Adjustment tools..... | 155 |
| 6.3.3 | Extractor handle..... | 155 |
| 6.3.4 | Tensioning tool..... | 155 |
| 6.3.5 | Mitre pliers..... | 156 |
| 6.4 | Punches..... | 156 |
| 6.4.1 | Pneumatic punch – PS 100..... | 156 |
| 6.4.2 | Hydropneumatic punch – DUO..... | 157 |

| | | | |
|---|----------|---|------------|
|  | 7 | Accessories..... 158 | 158 |
| | 7.1 | Control unit with Soft function..... | 158 |
| | 7.2 | Activator spare part for control unit with soft function..... | 159 |
| | 7.3 | Rubber buffer..... | 160 |
| | 7.4 | Label..... | 160 |
| <hr/> | | | |
|  | 8 | Brief instructions..... 162 | 162 |
| | 8.1 | Diagram A, A', K, K'..... | 162 |
| <hr/> | | | |
|  | 9 | Installation..... 163 | 163 |
| | 9.1 | Processing instructions..... | 163 |
| | 9.2 | Screw connections..... | 164 |
| | 9.2.1 | Overview..... | 165 |
| | 9.3 | Drilling and routing dimensions..... | 166 |
| | 9.3.1 | VT espagnolette..... | 166 |
| | 9.3.2 | VT espagnolette, lockable..... | 167 |
| | 9.3.3 | External recessed grip..... | 167 |
| | 9.3.4 | Diagram C – cam operating sequence control..... | 168 |
| | 9.3.5 | Striker H, can be routed in..... | 168 |
| | 9.3.6 | Rubber buffer..... | 169 |
| | 9.3.7 | Tilt protection device..... | 169 |
| | 9.4 | Force-fit connection..... | 170 |
| | 9.5 | Sash..... | 171 |
| | 9.5.1 | Cropping the hardware components..... | 171 |
| | 9.5.2 | Sash adapter profile..... | 172 |
| | 9.5.3 | Installation sequence..... | 174 |
| | 9.5.3.1 | Diagram A..... | 174 |
| | 9.5.4 | Corner drive..... | 175 |
| | 9.5.5 | Centre locks..... | 175 |
| | 9.5.5.1 | Centre lock, vertical..... | 175 |
| | 9.5.5.2 | Centre lock, horizontal..... | 176 |
| | 9.5.6 | VT espagnolette..... | 176 |
| | 9.5.7 | Handle and recessed grip..... | 177 |
| | 9.5.8 | Roller unit..... | 178 |

| | | |
|------------|--|------------|
| 9.5.9 | Control unit..... | 180 |
| 9.5.10 | Centre closer..... | 182 |
| 9.5.11 | Centre closer for anti-pushback function..... | 186 |
| 9.5.12 | Rubber buffer..... | 189 |
| 9.5.13 | Cover profile..... | 190 |
| 9.5.14 | Components in the floating mullion..... | 191 |
| 9.6 | Frame..... | 198 |
| 9.6.1 | Roller track..... | 198 |
| 9.6.2 | Operator track..... | 201 |
| 9.6.3 | Frame adapter profile..... | 204 |
| 9.6.4 | Gasket pad..... | 205 |
| 9.6.5 | Rubber buffer..... | 206 |
| 9.7 | Joining the sash and frame..... | 206 |
| 9.7.1 | Inserting the sash..... | 207 |
| 9.7.2 | Frame component position..... | 209 |
| 9.7.3 | Striker, screw-on..... | 212 |
| 9.7.3.1 | Preparing the frame for the striker, screw-on..... | 212 |
| 9.7.3.2 | Drilling the holes for the striker..... | 215 |
| 9.7.3.3 | Installing the striker..... | 216 |
| 9.7.4 | Striker to prevent incorrect operation..... | 217 |
| 9.7.4.1 | Drilling the holes for the striker to prevent incorrect operation..... | 217 |
| 9.7.4.2 | Installing the striker to prevent incorrect operation..... | 218 |
| 9.7.5 | MUL striker..... | 219 |
| 9.7.5.1 | Drilling the holes for the mullion striker..... | 219 |
| 9.7.5.2 | Installing the mullion striker..... | 220 |
| 9.7.6 | SEC MUL striker..... | 220 |
| 9.7.6.1 | Drilling the holes for the mullion security striker..... | 220 |
| 9.7.6.2 | Installing the SEC MUL striker..... | 221 |
| 9.7.7 | Striker for anti-pushback function..... | 222 |
| 9.7.8 | Activator and packer..... | 223 |
| 9.7.8.1 | Preparing the positioning jig..... | 223 |
| 9.7.8.2 | Diagram A..... | 224 |
| 9.7.8.3 | Diagram C..... | 227 |

| | | |
|----------|---|-----|
| 9.7.9 | Tensioning the control unit with soft function..... | 228 |
| 9.7.10 | Tilt protection device..... | 229 |
| 9.7.11 | Buffer..... | 231 |
| 9.7.11.1 | Drilling the holes for the buffer..... | 231 |
| 9.7.11.2 | Installing the buffer..... | 232 |
| 9.7.12 | End stop with packer..... | 233 |
| 9.7.13 | Operator track stopper..... | 234 |
| 9.7.14 | Notes on final assembly..... | 236 |



| | | |
|-----------|---|------------|
| 10 | Installation drawings..... | 237 |
| 10.1 | Explanation..... | 237 |
| 10.2 | Diagram A, K, A', K'..... | 238 |
| 10.3 | Diagram A, K RC 2 / RC 2 N PVC..... | 239 |
| 10.4 | Diagram C, C'..... | 240 |



| | | |
|-----------|--|------------|
| 11 | Adjustment..... | 241 |
| 11.1 | Striker..... | 241 |
| 11.2 | Adjusting the locking cam..... | 241 |
| 11.3 | MUL locking cam / pin for anti-pushback function – adjustable..... | 242 |





| | | |
|-----------|----------------------------|------------|
| 12 | Operation..... | 244 |
| 12.1 | Operating information..... | 244 |
| 12.1.1 | Roto Patio Inowa..... | 244 |
| 12.2 | Fault assistance..... | 244 |



| | | |
|-----------|----------------------------|------------|
| 13 | Maintenance..... | 245 |
| 13.1 | Maintenance intervals..... | 245 |
| 13.2 | Cleaning..... | 246 |
| 13.3 | Care..... | 246 |
| 13.3.1 | Roto Patio Inowa..... | 247 |
| 13.4 | Performance test..... | 247 |
| 13.5 | Repair..... | 248 |



| | | |
|-----------|--------------------------|------------|
| 14 | Dismantling..... | 249 |
| 14.1 | Unhinging the sash..... | 249 |
| 14.2 | Hardware components..... | 251 |

| | | | |
|---|-----------|---|------------|
|  | 15 | Transport..... | 252 |
| | 15.1 | Transporting elements and hardware..... | 252 |
| | 15.2 | Storing the hardware..... | 253 |
|  | 16 | Disposal..... | 254 |
| | 16.1 | Disposing of packaging..... | 254 |
| | 16.2 | Disposing of hardware..... | 254 |

1 General information

1.1 Version history

| Version | Date | Changes |
|---------|------------|--|
| v0 | 16/11/2015 | |
| v1 | 11/12/2015 | |
| v2 | 03/03/2016 | |
| v3 | 10/12/2017 | <p>General information, Security, Maintenance, Transport and Disposal chapters added.</p> <p>Installation of frame components, end stop, operator track stop and packer added.</p> <p>Jigs changed.</p> <p>Centre closers changed.</p> <p>Hardware overviews and parts lists changed.</p> |
| v4 | 22/10/2018 | <p>Brief instructions added → <i>from page 162</i>.</p> <p>Notes on final assembly added → <i>from page 236</i>.</p> <p>Routing pattern for timber mullion striker removed.</p> <p>Incorrect material no. amended.</p> <p>Installation of roller unit, control unit and centre closer; assignment of drilling jig to diagram amended.</p> <p>Installation of diagram C components</p> <p>Frame component positions changed → <i>from page 209</i>.</p> |
| v5 | 13/06/2019 | <p>Diagram C / C' CL component, vertical, on the mullion side: combinations added.</p> <p>Diagram C instruction sticker added.</p> <p>Incorrect material no. amended.</p> <p>Dimensions for installing components in the mullion amended.</p> <p>Pin for anti-pushback function amended.</p> <p>Installation dimensions for operator track stopper amended.</p> <p>Diagram C installation drawings amended.</p> |
| v6 | 06/09/2019 | <p>Hardware overview with RC 2 parts list for PVC added .</p> <p>Installation of mullion security striker added → <i>from page 220</i>.</p> <p>Installation of anti-pushback function added → <i>from page 222</i>.</p> <p>Installation drawing diagram A – RC 2 / RC 2 N – PVC added .</p> <p>Incorrect material no. amended.</p> <p>Routing depth for VT gearbox amended → <i>from page 166</i>.</p> <p>Assignment of dimensions in the first opening sash and figure showing the position of the anti-lifting device amended → <i>from page 191</i>.</p> <p>Table of strikers, on the locking side, can be routed in, changed → <i>from page 209</i>.</p> |

| Version | Date | Changes |
|---------|------------|--|
| v7 | 31/10/2019 | <p>Frame component positions for RC and striker for anti-pushback function added → <i>from page 209</i>.</p> <p>All hardware overviews amended.</p> <p>In parts lists, size-dependent combinations for CL component, vertical, amended.</p> <p>Drilling jig for mullion security striker amended → <i>from page 220</i>.</p> <p>Drilling jig for striker for anti-pushback function amended → <i>from page 222</i>.</p> <p>Drilling pattern for striker H, can be routed in: dimensions amended → <i>from page 168</i>.</p> <p>Components in the floating mullion – PVC: positions in the second opening sash amended → <i>from page 191</i>.</p> <p>Frame component positions amended → <i>from page 209</i>.</p> <p>Striker to prevent incorrect operation: dimensional drawings in the open sliding position amended → <i>from page 217</i>.</p> <p>Operator track stopper position amended → <i>from page 234</i>.</p> <p>All installation drawings amended (dimensioning of the sizes rounded up) → <i>from page 237</i>.</p> |
| v8 | 23/04/2021 | <p>Centre fixing is undone by being screwed down. Changed for roller unit, control unit and centre closer.</p> <p>Roller unit, control unit and centre closer changed.</p> <p>Installation drawings changed → <i>from page 237</i>.</p> <p>Component drawings added → <i>from page 30</i>.</p> <p>Components with Soft function added → <i>from page 158</i>.</p> <p>Mullion locking cam – now also adjustable – added.</p> <p>Adjustment of adjustable components added → <i>from page 242</i>.</p> <p>Operation changed → <i>from page 244</i>.</p> |
| v9 | 26/08/2022 | <p>Application range 3:1 added → <i>from page 27</i>.</p> <p>Tilt protection device added.</p> <p>Roller track dimensions added → <i>from page 30</i>.</p> <p>Hardware overviews divided according to timber and PVC and added accordingly.</p> <p>Customer-specific hardware overviews added → <i>from page 54</i>.</p> <p>Order quantities added to parts lists.</p> <p>Mat. no. CL 480 in “Size-dependent combination” tables amended.</p> <p>Structure of centre locks in parts list amended.</p> <p>Some drilling jigs for REHAU removed. Replacement: combination drilling jig.</p> <p>Drilling jig for activator added → <i>from page 154</i>.</p> <p>Drilling jig for stopper added → <i>from page 154</i>.</p> |

| Version | Date | Changes |
|---------|------------|---|
| v10 | 28/07/2023 | <p>Maximum sash weight changed to 250 kg.</p> <p>Maximum sash rebate width for diagram C changed to 1500 mm.</p> <p>Diagram C tilt protection device added.</p> <p>Diagram C added for Salamander evolutionDrive Plus+ → <i>from page 106.</i></p> <p>aluplast smart-slide neo added → <i>from page 66.</i></p> <p>Schüco Living move added → <i>from page 112.</i></p> <p>Screw overview added → <i>from page 165.</i></p> <p>Notching of customer-specific profile added → <i>from page 190.</i></p> <p>Installation of asymmetrical components added.</p> <p>Notes on the component test for centre closers added → <i>from page 182.</i></p> <p>Diagram C for GEALAN Smoovio VT espagnolette for second opening sash changed to BS 25 → <i>from page 86.</i></p> <p>Formula for cutting the adapter profile amended → <i>from page 172.</i></p> <p>Formula for cutting the operator track amended → <i>from page 201.</i></p> <p>Installation of activator with packer amended (new drilling jigs) → <i>from page 223.</i></p> <p>REHAU Synego Slide VT espagnolette BS 35 removed.</p> |

1.2 Instructions

This manual contains important information, instructions, application diagrams (max. sash sizes and weights) and assembly instructions for the installation, maintenance and operation of hardware.

The information and instructions contained in this document refer to products belonging to the Roto hardware system named on the front page.

All steps must be completed in sequence.

The following documents apply in addition to these instructions:

- Handles catalogue: CTL_1

The following guidelines also apply:

Gütegemeinschaft Schlösser und Beschläge e.V.

- Directive TDK: Attachment of supporting fitting components for turn-only and tilt&turn fittings
- Directive VHBE: Hardware for windows and balcony doors – Guidelines/ advice for end-users
- Directive VHBH: Hardware for windows and balcony doors – Guidelines/ advice on the product and on liability

VFF (German Window and Facade Association)

- TLE.01: Correct handling of ready-to-install windows and external doors during transport, storage and installation
- WP.01: Maintenance of windows, facades and external doors – Maintenance, care and inspection – Information for sales
- WP.02: Maintenance of windows, facades and external doors – Maintenance, care and inspection – Measures and documents
- WP.03: Maintenance of windows, facades and external doors – Maintenance, care and inspection – Maintenance agreement

Additional guidelines

- Instructions and information issued by profile manufacturers, e.g. manufacturers of windows and balcony doors
- Instructions and information issued by screw manufacturers
- The applicable regulations, directives and national laws

Storing the instructions

These instructions are an important part of the product. The instructions must be stored so that they are always to hand.

Explanation of the markings

The manual uses the following markings for emphasis (e.g. in figures or instructions):

| Marking | Meaning |
|---------|---|
| | Sash |
| | Frame |
| | Drill holes, routing or screw positions |
| | Unaffected components / indirectly affected components |
| | Components, arrows or movements that have just been described |
| | Item number |
| [1] | Legend |
| [A] | Steps |



INFO

Any dimensions without a unit in the instructions are given in millimetres (mm). Other units of measurement are clearly indicated by the presence of the differing unit.















INFO

Figures are provided in the left-hand version. The process for the right-hand version is mirror-inverted.

1.3 Symbols

















| Symbol | Meaning |
|--------|----------------------------|
| ■ | First-level list |
| □ | Second-level list |
| → | (Cross-)reference |
| ▷ | Result |
| ▶ | Unnumbered step |
| 1. | Numbered step |
| a. | Numbered second-level step |
| ⇨ | Requirement |



1.4 Pictographs

| Symbol | Meaning |
|---|--|
|  | Timber / PVC |
|  | Timber |
|  | PVC |
|  | Sash rebate width |
|  | Sash rebate height |
|  | Handle position vertically upwards |
|  | Handle position vertically downwards |
|  | Sash handle height (centre-left) |
|  | Left of sash |
|  | Top of sash |
|  | Top right and bottom right of sash |
|  | Top and bottom of sash |
|  | Top left and right and bottom left and right of sash |
|  | Right of sash |
|  | Bottom of sash |
|  | Sash diagram C, second opening sash, right |
|  | Left of frame |
|  | Bottom left of frame |
|  | Top left of frame |
|  | Top right of frame |
|  | Top and bottom right of frame |
|  | Bottom of frame |

| Symbol | Meaning |
|---|----------------------|
|  | Bottom left of frame |

1.5 Product features

| Symbol | Meaning |
|---|-------------------------------|
|  | Cropping range |
|  | Width |
|  | Description |
|  | Backset |
|  | Installation DIN left / right |
|  | Colour |
|  | Colour code, Roto |
|  | Sash width |
|  | Sash height |
|  | Sash weight |
|  | Fixed handle height |
|  | Information |
|  | couplable |
|  | Length |
|  | Material |
|  | Material number |
|  | Installation type |

| Symbol | Meaning |
|---|------------------------|
|  | Surface |
|  | Number of locking cams |
|  | Type of locking cams |

1.6 Abbreviations

| Abbreviation | Meaning |
|--------------|---------------------------|
| Approx. | Approximately |
| CTL | Catalogue |
| BS | Backset |
| E | E cam |
| IMO | Installation instructions |
| SRW | Sash rebate width |
| SRH | Sash rebate height |
| S.kg | Sash weight |
| T / PVC | Timber / PVC |
| KU | Couplable |
| kg | Kilograms |
| KSR | Vertical tilting |
| L | Left |
| Max. | Maximum |
| MUL | Mullion |
| Min. | At least |
| mm | Millimetres |
| CL | Centre lock |
| Nm | Newton metres |
| Not sh. | Not shown |
| P | Mushroom cam |
| R | Right |
| FEW | Frame external width |
| FEH | Frame external height |
| FIW | Frame internal width |
| RC | Resistance class |
| WAF | Width across flats |
| V | V cam |
| e.g. | For example |

1.7 Target groups

The information in this document is directed at the following target groups:

Hardware dealers

The “hardware dealers” target group includes all companies and individuals that purchase hardware from hardware manufacturers for resale, without modifying or further processing the hardware.

Window and balcony door manufacturers

The “window and balcony door manufacturers” target group includes all companies and individuals that purchase hardware from hardware manufac-

turers or hardware dealers and further process the hardware by integrating it in windows and balcony doors.

Building element dealers or installation companies

The "building element dealers or installation companies" target group includes all companies and individuals that purchase windows and balcony doors from window and balcony door manufacturers for resale and for installation in construction projects, without modifying the windows or balcony doors.

Builders

The "builders" target group includes all companies and individuals who place orders for the manufacture of windows and balcony doors for installation in their construction projects.

End users

The "end users" target group includes all individuals who use the installed windows and balcony doors.

1.8 Target groups' obligation to give instructions



INFO

Each target group must fulfil their obligation to give instructions in full.

Unless specified otherwise in the text below, documents and information can be passed on as a printed document, on a data storage device or via the Internet.

Responsibility of hardware dealers

Hardware dealers must pass the following documents on to the window and balcony door manufacturer:

- Catalogue
- Installation, maintenance and operation instructions
- Directive on attachment of supporting fitting components for turn-only and tilt&turn fittings (TBDK)
- Guidelines/advice on the product and on liability (VHBH)
- Guidelines/advice for end-users (VHBE)

Responsibility of the window and balcony door manufacturer

The window and balcony door manufacturer must pass the following documents on to building element dealers or the builder, even if a subcontractor (installation company) is involved:

- Installation, maintenance and operation instructions
- Directive on attachment of supporting fitting components for turn-only and tilt&turn fittings (TBDK)
- Guidelines/advice on the product and on liability (VHBH)
- Guidelines/advice for end-users (VHBE)

They must ensure that the end users are provided with the documents and information intended for them in printed format.

Responsibility of building element dealers and the installation company

Building element dealers must pass the following documents on to the builder, even if a subcontractor (installation company) is involved:

- Installation, maintenance and operation instructions (with a focus on hardware)
- Guidelines/advice on the product and on liability (VHBH)
- Guidelines/advice for end-users (VHBE)

Responsibility of the builder

The builder must pass the following documents on to the end user:

- Installation, maintenance and operation instructions (with a focus on hardware)
- Guidelines/advice for end-users (VHBE)

1.9 Copyright protection

The contents of this document are copyright-protected. This content can be used when working with the hardware. Any other use is not permitted without written permission of the manufacturer.

1.10 Limitation of liability

All information and instructions contained in this document have been compiled in consideration of the applicable standards and regulations, the latest developments in technology and many years of knowledge and experience.

The hardware manufacturer assumes no liability for damage caused by:

- Failure to comply with this document and all product-specific documents and other applicable directives (see the chapters entitled "Security" and "Stipulated use").
- Improper use / misuse (see the chapters entitled "Security" and "Stipulated use").
- Insufficient invitation to tender, non-compliance with installation specifications and non-compliance with the application diagrams (where available).
- Increased contamination.

Claims made by third parties against the hardware manufacturer on account of damage resulting from misuse or failure to comply with the obligation to give instructions on the part of hardware dealers, window, door and balcony door manufacturers and building element dealers or the builder are passed on accordingly.

The obligations agreed in the delivery contract, the general terms and conditions, the hardware manufacturer's terms and conditions of delivery and the legal provisions applicable when the contract was concluded shall apply.

The warranty only covers original Roto components.

We reserve the right to make technical changes as part of improvement to performance characteristics and further development.

1.11 Preserving the surface finish



ATTENTION

Surface treatments may cause property damage.

Surface treatments (e.g. painting and varnishing) on elements can damage components or prevent them from working properly.

- ▶ For masking, only use adhesive tape that does not damage the paint coats. Consult the manufacturer if in doubt.
- ▶ Protect components against direct contact with the surface treatment.
- ▶ Protect components against contamination.



ATTENTION

Using incorrect cleaning agents and sealing compounds may cause property damage.

Cleaning agents and sealing compounds may damage the surfaces of components and gaskets.

- ▶ Do not use aggressive or flammable liquids, acidic cleaners or abrasive cleaners.
- ▶ Only use mild, pH-neutral cleaning agents that have been diluted.
- ▶ Apply a thin protective film to the components, for example using a cloth soaked in oil.
- ▶ Avoid aggressive vapours (e.g. produced by formic acid, acetic acid, ammonia, amine compounds, ammonia compounds, aldehyde, carboric acid, chlorine, tannic acid) around the element.
- ▶ Do not use any acetic acid-crosslinking or acid-crosslinking sealing compounds or those with the aforementioned constituents as both direct contact with the sealing compound and its fumes can corrode the surface of the components.



ATTENTION

Contamination may cause property damage.

Contamination prevents components working properly.

- ▶ Remove deposits and contamination caused by construction materials (e.g. plaster, gypsum).
- ▶ Keep components free of deposits and contaminants.



ATTENTION

(Permanently) damp room air may cause property damage.

Damp room air can lead to mould growth and corrosion caused by condensation.

- ▶ Provide adequate ventilation for components, particularly during the construction phase.
- ▶ Intensively air out the room several times per day by opening all elements for approximately 15 minutes. If intensive airing is not an option, place the elements in the tilt position and provide airtight masking inside the room, e.g. if there is fresh screed that cannot be walked on or must not be exposed to draughts. Discharge any humidity present in the room air to the outside using condensation dryers.
- ▶ Establish a ventilation plan for more complex construction projects if necessary.
- ▶ Provide adequate ventilation during holiday periods as well.

2 Security

This manual contains instructions relating to safety. The principal safety information in this chapter includes information and instructions relevant to the safe use or maintaining the safe condition of the product. Warning instructions that relate to handling warn of residual risks and are located before steps that are relevant to safety.

- ▶ Follow all of the instructions in order to prevent personal injury and property and environmental damage.

2.1 Presentation and structure of warning instructions

The warning instructions relate to individual actions and are structured as follows with a warning symbol:



DANGER

Nature and source of the danger.

Explanation and description of the danger and the implications.

- ▶ Measures to take to avert the danger.

2.2 Security levels of warning instructions

The warning instructions that relate to handling are identified differently according to the severity of the associated danger. The signal words and the associated warning symbols used are clarified below.



DANGER

Immediate risk of death or serious injuries.

- ▶ Observe these warning instructions to avoid personal injuries.



WARNING

Potential risk of death or serious injuries.

- ▶ Observe these warning instructions to avoid personal injuries.



CAUTION

Risk of injuries

- ▶ Observe these warning instructions to avoid personal injuries.



ATTENTION

Reference to property or environmental damage.

- ▶ Observe these warning instructions to avoid property or environmental damage.

2.3 Stipulated use

The hardware system described in these instructions is intended for installation in sliding sashes in windows and balcony doors. The hardware system is only intended for further processing on windows and balcony door sashes for vertical installation made from the materials described in these instructions. The hardware system opens sashes in windows and balcony doors and closes them tightly.

Stipulated use also includes compliance with all safety information and specifications contained in these instructions, the other applicable documents and the applicable regulations, directives and national laws.



2.3.1 Misuse

Any use and processing of the products that goes beyond or differs from the stipulated use is considered misuse and can lead to hazardous situations.



WARNING

Misuse may pose a risk of death!

Misuse and incorrect installation of hardware can lead to serious injuries.

- ▶ Only use hardware combinations that have been approved by the hardware manufacturer.
- ▶ Only use original accessories or those that have been approved by the hardware manufacturer.
- ▶ Note the product-related documentation → *from page 10*.

2.3.2 Usage restriction

Opened sashes in windows and balcony doors, and windows and balcony door sashes that are unlocked or placed in ventilation positions, only have a shielding effect. They do not meet the following requirements:

- Joint sealing
- Driving rain impermeability
- Sound insulation
- Thermal insulation
- Burglary inhibition

2.4 Stipulated use for end users

On windows or balcony doors with sliding hardware, window sashes or balcony door sashes can be moved horizontally or vertically by operating a handle.

On special structures, various sashes can additionally be brought into a turn position and / or into a tilt position restricted by the scissor stay version.

When closing a sash and locking the hardware, the gasket counter force must generally be overcome.



WARNING

Opening and closing sashes in an uncontrolled manner may pose a risk of fatal injury!

Opening and closing the sash in an uncontrolled manner may lead to serious injuries.

- ▶ Ensure that the sash does not collide with the frame, opening restrictor (buffer) or other sashes when it is moved into the fully open or closed position.
- ▶ Ensure that the sash is slowly guided by hand throughout its entire movement range, until it has been brought into a fully closed or opening position.
- ▶ Ensure that the sash coverage at the top is so large that the sash is prevented from falling out, even if the window or hardware components is / are operated incorrectly.



ATTENTION

Opening and closing sashes in an uncontrolled manner may result in property damage.

Opening and closing the sash in an uncontrolled manner may cause the element to malfunction.

- ▶ Ensure that the sash does not collide with the frame, opening restrictor (buffer) or other sashes when it is moved into the fully open or closed position.
- ▶ Ensure that the sash is slowly guided by hand throughout its entire movement range, until it has been brought into a fully closed or opening position.

Any use and processing of the products that goes beyond or differs from the stipulated use is considered misuse and can lead to hazardous situations.

No claims of any kind can be made on account of damage resulting from failure to comply with the stipulated use.

2.4.1 Misuse

Any use and processing of the products that goes beyond or differs from the stipulated use is considered misuse and can lead to hazardous situations.



WARNING

Misuse may pose a risk of death!

Misuse and incorrect installation of hardware can lead to serious injuries.

- ▶ Only use hardware combinations that have been approved by the hardware manufacturer.
- ▶ Only use original accessories or those that have been approved by the hardware manufacturer.
- ▶ Note the product-related documentation → *from page 10*.

2.5 Basic safety information

The following hazards may arise when handling the product:

2.5.1 Installation

Incorrect installation poses an immediate risk of death or serious injuries.

Incorrect installation or assembly of hardware can lead to hazardous situations or property damage. Depending on the height of the fall, this can result in serious to life-threatening injuries and glass breakage.

- ▶ Only use hardware combinations that have been approved by the hardware manufacturer.
- ▶ Only use original accessories or those that have been approved by the hardware manufacturer.
- ▶ Always have installation performed by a specialist company.

Heavy loads pose a risk of injury.

Lifting and carrying heavy loads may lead to injuries in the event of a fall or physical overexertion.

- ▶ Note the applicable accident prevention regulations.



- ▶ Transport heavy loads with two people and use suitable transportation means (such as an industrial truck).

Physical overexertion may be harmful to health.

Moving heavy loads for extended periods leads to physical injury in the long term.

- ▶ When carrying and lifting by hand, comply with a maximum weight of 25 kg for men and 10 kg for women.
- ▶ Carry and lift even small loads with an ergonomically correct posture.

2.5.2 Use

Falls from open windows and balcony doors present an immediate risk of death and pose the risk of serious injuries.

Opened sashes of windows and balcony doors create a danger zone. Depending on the height of the fall, this can result in serious to life-threatening injuries and glass breakage.

- ▶ Take care when in the vicinity of open windows and balcony doors.
- ▶ Keep children and anyone unable to understand the risks away from the hazardous area.

Trapping body parts in the opening between sash and frame may lead to serious injuries.

Gripping between the sash and frame when closing windows and balcony doors poses the risk of crushing injuries.

- ▶ When closing windows and balcony doors, never grip between the sash and frame and always exercise caution.
- ▶ Keep children and anyone unable to understand the risks away from the hazardous area.

Opening and closing leaves improperly poses the risk of injury and property damage.

Incorrect opening and closing of leaves can result in serious injuries and substantial property damage.

- ▶ When moving the sash, ensure that it will not slam against the frame or other leaves once fully opened or closed.
- ▶ Ensure that the sash is slowly guided by hand throughout its entire movement range, until it has been brought into a fully closed or opening position.
- ▶ When closing a sash and locking the hardware, the gasket counter force must be overcome.

Misuse poses a risk of injury and property damage.

Misuse can lead to hazardous situations and may destroy the hardware, frame materials or other individual components within the windows or balcony doors.

- ▶ Do not introduce any obstacles in the opening area between the frame and window or balcony door sashes.
- ▶ Do not place additional loads on windows and balcony door sashes.

- ▶ Refrain from intentionally or uncontrollably slamming or pushing the window or balcony door sash against the window reveal or the opening restrictor.

Improper maintenance poses the potential risk of injury and property damage.

Windows and balcony doors, including the hardware, require expert maintenance (care, cleaning, maintenance and inspection) in order to guarantee their proper condition and safe use.

- ▶ Keep the hardware free of deposits and contaminants.
- ▶ Carry out care and cleaning tasks as specified in these instructions.
- ▶ Always have regular maintenance, adjustment and repair work carried out by a specialist company.

2.5.3 Ambient conditions

Physical and chemical influences may result in property damage.

Hardware components can be permanently damaged in a saline, aggressive or corrosive environment to the point that they can no longer function.

- ▶ Do not use the hardware components in a saline, aggressive or corrosive environment.
- ▶ Carry out care and cleaning tasks as specified in these instructions.
- ▶ Corrosion protection must be inspected by an authorised specialist company as part of regular maintenance work.

Moisture may cause property damage.

Depending on the outside temperature, relative humidity of the room air and installation situation of the windows and balcony doors, a temporary build-up of condensation may occur. This can lead to corrosion on the hardware and mould growth on the frame or wall. Ambient conditions that are too damp, particularly during the construction phase, can lead to timber elements warping.

- ▶ Avoid preventing the circulation of air (e.g. due to deep reveals, curtains and unfavourable positioning of heaters or the like).
- ▶ Intensively air out the room several times per day.
 Open all windows and balcony doors for approximately 15 minutes so that the air in the room can be completely replaced.
- ▶ Provide adequate ventilation during holiday periods as well.
- ▶ Create a ventilation plan for construction projects if necessary.

2.6 Operation

The safety symbols and markings and the associated warning instructions explained below apply to the safe operation of windows and balcony doors.

Safety symbols and markings

| Symbol | Meaning |
|---|---|
|  | <p>Falls from open windows and balcony doors present an immediate risk of death and pose the risk of serious injuries.</p> <p>Take care when in the vicinity of open windows and balcony doors.</p> <p>Keep children and anyone unable to understand the risks away from the hazardous area.</p> |



| Symbol | Meaning |
|--------|--|
| | <p>Trapping body parts in the opening between sash and frame may lead to serious injuries.</p> <p>When closing windows and balcony doors, never grip between the sash and frame and always exercise caution.</p> <p>Keep children and anyone unable to understand the risks away from the hazardous area.</p> |
| | <p>Placing additional loads on the sash may lead to minor injuries and property damage.</p> <p>Do not place additional loads on windows and balcony door sashes.</p> |
| | <p>Introducing obstacles into the opening between sash and frame may result in minor injuries and property damage.</p> <p>Do not introduce any obstacles in the opening area between the frame and window or balcony door sashes.</p> |
| | <p>Opening and closing the sash in an uncontrolled manner may result in minor injuries and property damage.</p> <p>Ensure that the sash is slowly guided by hand throughout its entire movement range, until it has been brought into a fully closed or opening position.</p> |

3 Information on the product

3.1 General hardware characteristics

- Circumferential gasket
- Concealed hardware
- Intuitive, simple operation
- Even heavy sashes can be opened with less effort because the handle is easy to use.
- Ease of closing thanks to the smooth automatic retraction of the sash into the frame.
- Innovative closing movement perpendicular to the frame profile.
- Active locking points including in the mullion.
- PVC RC 2 / RC 2 N: SKG**-certified
- Control unit with soft function:
 - SoftClose (damped closing)
 - SoftOpen (damped opening)

3.2 Application ranges

- The sash runs within the frame profile with a retracting distance of 8 mm.
- Narrow profile views possible
- SRW 710 mm – 2000 mm
SRW differs for two control units with Soft function 920 mm – 2000 mm
- SRH 600 mm – 2500 mm
- S.kg max. 250 kg
- Opening diagrams:
 - A and A' (running inward or outward)
 - K and K' (running inward or outward)
 - C and C' (running inward or outward)
- Basic security and RC 2 / RC 2 N resistance class
- Operating range -20 °C to +80 °C



3.3 Application diagrams

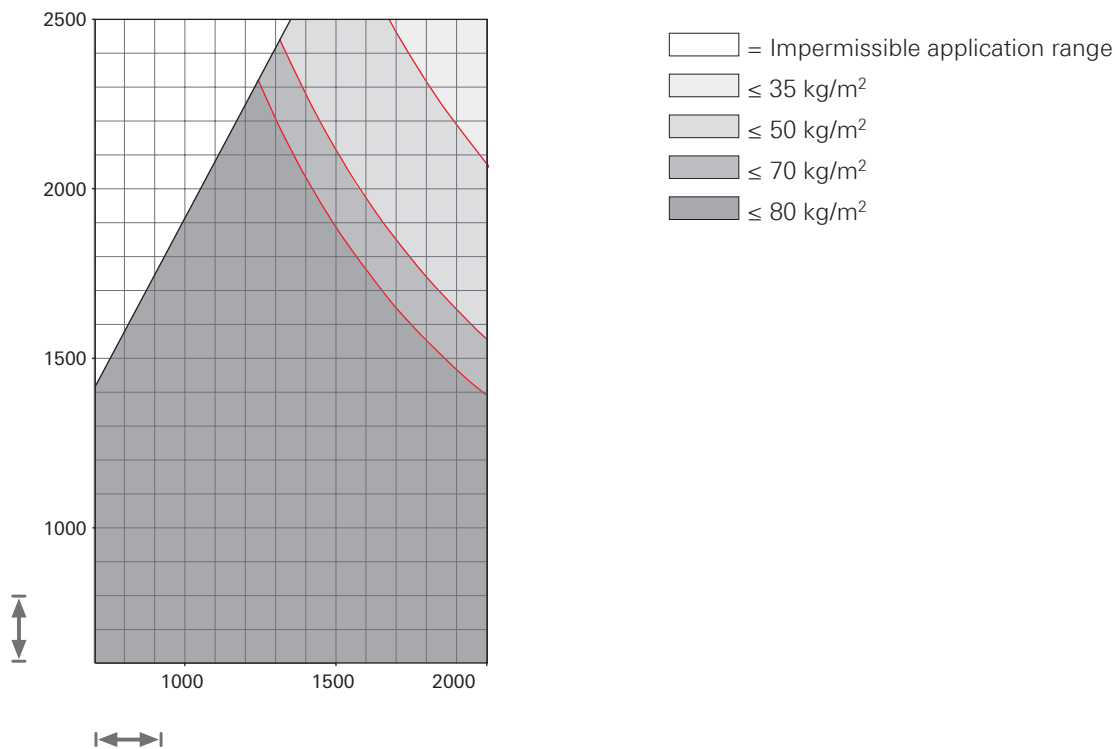

3.3.1 200 kg

SRH:SRW = max. 2:1



The specifications in the application diagram refer to the glass weight in kg/m^2 .

1 mm/m² glass thickness \approx 2.5 kg

| | | Application range | |
|---|--------------------------|------------------------------------|-------------------------|
|  | Sash rebate width (SRW) | Control unit without Soft function | 710 – 2000 mm |
| | | 1 control unit with Soft function | 710 – 2000 mm |
| | | 2 control units with Soft function | 920 – 2000 mm |
|  | Sash rebate height (SRH) | | 600 – 2500 mm |
|  | Sash weight (S.kg) | | Max. 250 kg |
| - | Glass weight | | Max. 80 kg/m^2 |



INFO

When using control units with soft function:

S.kg > 20 kg

SRH:SRW = > 2:1 up to max. 3:1 – with tilt protection device

For PVC profiles, diagrams A, A', K and K'. Diagrams C and C' available upon request.



DANGER

The uncontrolled tilting of sashes with aspect ratios > 2:1 poses a risk of death!

Uncontrolled tilting may cause sashes with aspect ratios > 2:1 to jump out of the operator track. This many lead to hazardous situations and cause serious or fatal accidents.

- ▶ The roller track must have two walls → 3.6 "Dimensions of the roller track" from page 30.
- ▶ Install the tilt protection device (only without control unit with Soft function) → 3.7 "Dimensions of the tilt protection device" from page 30.
- ▶ An installation space examination is a mandatory part of a profile assessment.

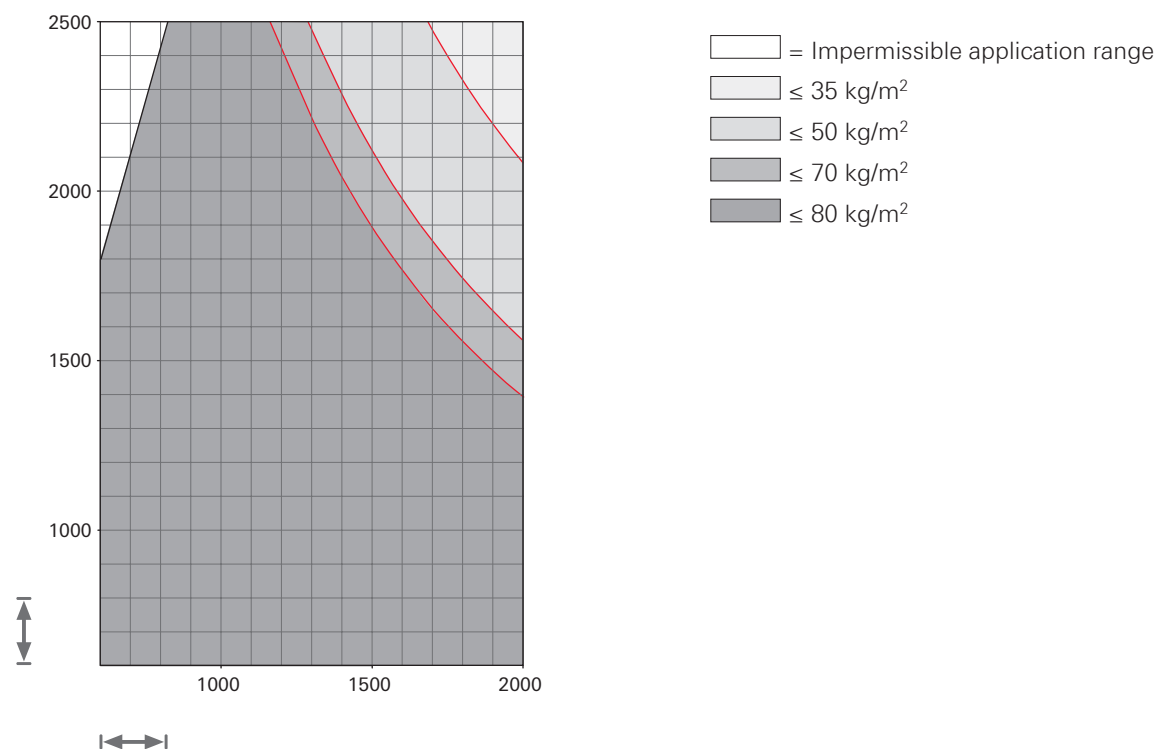

The specifications in the application diagram refer to the glass weight in kg/m².

1 mm/m² glass thickness ≅ 2.5 kg



INFO

The use of control units with Soft function is not possible with aspect ratios > 2:1.

| | | Application range |
|----|-----------------------------|---------------------------|
| ↔ | Sash rebate width (SRW) | 710 – 2000 mm |
| ↑↓ | Sash rebate height (SRH) | 600 – 2500 mm |
| 🏠 | Sash weight (S.kg) | Max. 250 kg |
| - | Glass weight | Max. 80 kg/m ² |



3.4 Design variants

3.4.1 Overview

Diagram A

| Diagram A (running on the inside) | Diagram A' (running on the outside) |
|---|---|
| | |
| 1 sliding sash (left or right) 1 fixed glazing element | 1 sliding sash (left or right) 1 fixed glazing element |

Diagram C

| Diagram C (running on the inside) | Diagram C' (running on the outside) |
|---|---|
| | |
| 2 sliding sashes (left and right) 2 fixed glazing elements | 2 sliding sashes (left and right) 2 fixed glazing elements |

Diagram K

| Diagram K (running on the inside) | Diagram K' (running on the outside) |
|--|--|
| | |
| 2 sliding sashes (left and right) 1 fixed glazing element | 2 sliding sashes (left and right) 1 fixed glazing element |

3.5 Hardware groove dimensions

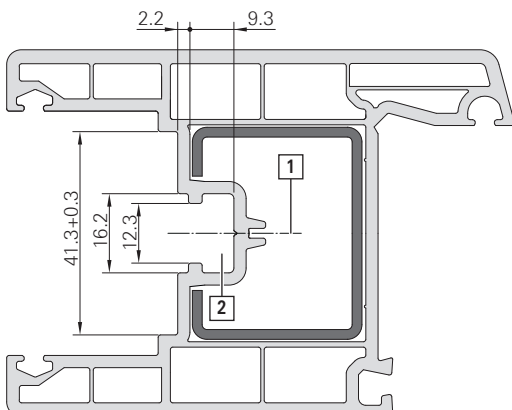

Sash profile cross section

[1] Hardware axis

[2] Hardware groove

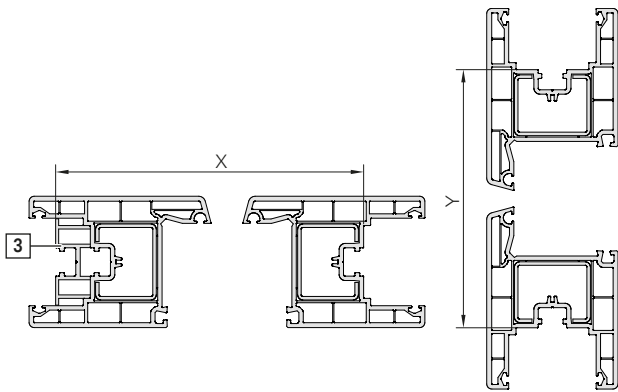

X = SRW (including assembly profile [3])
 Y = SRH

3.6 Dimensions of the roller track



INFO

Roller track only made from stainless steel or anodised aluminium.

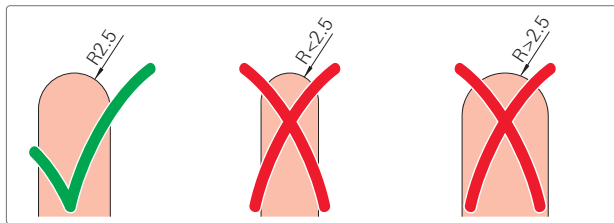

Roller track shape

3.7 Dimensions of the tilt protection device

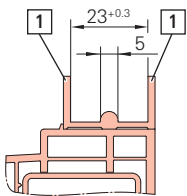

Two walls [1] next to the roller track are required for aspect ratios > 2:1.

3.8 Component dimensions

| MUL locking cam | Description |
|-----------------|-------------------------------|
| | L = 17.4 - 62.4 |
| | Adjustable L = 19.8 - 53.5 |

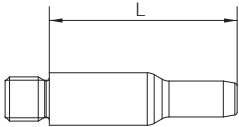
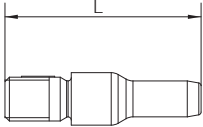

| Pin for anti-pushback function | Description |
|--|-------------------------------|
|  A technical drawing of a cylindrical pin with a chamfered end. A dimension line above the pin is labeled 'L', indicating the length from the chamfered end to the other end. | L = 20.0 - 46.5 |
|  A technical drawing of an adjustable cylindrical pin with a chamfered end. A dimension line above the pin is labeled 'L', indicating the length from the chamfered end to the other end. | Adjustable L = 35.5 - 53.5 |

4 Hardware overviews

The hardware overviews on the following pages are a recommendation on the part of Roto Frank Fenster- und Türtechnologie GmbH.

The basic page layout in the hardware overviews chapter firstly shows examples of the combination of individual hardware components, and the associated parts list can be seen on the following pages.

The item numbers in the squares link the hardware overview to the parts list.

The actual composition of the hardware depends on:

- the width of the element
- the height of the element
- the weight of the element
- the profile system
- the design variant

Application range

The applicable application range [A] depends on the opening type and resistance class. The application range of the individual components [B] may differ from the applicable application range [A].

Anwendungsbereich

FFB: 290 - 1600 mm

[A] **FFH:** 430 - 2800 mm

FG: max. 150 kg

[1] DK-Getriebe KSR – Griffsitz konstant, Dornmaß 15 mm

| | | | | | | | | | | | Nº |
|------------|-------------|------|------|---|---|---|---|---|---|---|--------|
| [B] | 280 – 570 | 120 | 460 | J | N | – | – | – | – | – | 742199 |
| | 511 – 710 | 170 | 600 | J | J | – | – | – | – | – | 795324 |
| | 601 – 800 | 263 | 690 | N | J | – | – | – | – | – | 619591 |
| | 801 – 1000 | 413 | 890 | N | J | 1 | E | – | – | – | 619592 |
| | 1001 – 1200 | 513 | 1090 | N | J | 1 | E | – | – | – | 619593 |
| | 1201 – 1400 | 563 | 1290 | N | J | 1 | E | – | – | – | 619594 |
| | 1401 – 1600 | 563 | 1490 | N | J | 2 | E | – | – | – | 619595 |
| | 1601 – 1800 | 563 | 1690 | N | J | 2 | E | – | – | – | 619596 |
| | 1601 – 1800 | 1000 | 1690 | N | J | 2 | E | – | – | – | 838345 |
| | 1801 – 2000 | 1000 | 1890 | N | J | 2 | E | – | – | – | 794637 |
| | 2001 – 2200 | 1000 | 2090 | N | J | 3 | E | – | – | – | 794638 |
| | 2201 – 2400 | 1000 | 2290 | N | J | 3 | E | – | – | – | 794639 |

Example

The highlighted T&T espagnolette can generally be used from a SRH of min. 280 mm [B]. With this opening type and resistance class, elements are only allowed to be constructed from an SRH of 430 mm [A] and above. The highlighted T&T espagnolette is in the specified range and can therefore be installed.



INFO

Profile properties

Design the profile optimally for the corresponding weights. Proper load transfer must be ensured by the profile manufacturer / fabricator.

Ensure that the rollers on the roller track run smoothly. Keep the roller track clean, do not powder coat or paint it.

The currently valid Roto profile assessment drawing for the specific profile and the applicable documents described in said drawing must be observed.

Please request these details from your responsible Roto sales representative.

Recommended handles can be found in the Roto Handles catalogue.

Determine the quantity of required hardware components with Roto Con Orders.



INFO

Roto Con Orders

Efficient online hardware configurator for the custom configuration of individual window and door hardware components. All conventional shapes and opening types can be automatically configured quickly and easily. Individual parts lists, including application ranges and an exemplary hardware overview, can be ordered from your responsible sales representative.



www.roto-frank.com

4.1 Timber

4.1.1 Diagram A, K





Application range

SRW: 710 – 2000 mm

SRH: 600 – 2500 mm

S.kg: max. 250 kg

| | | | |
|--------------------------|------------|--|--------|
| [1a] Corner drive | With E cam | | 2 |
| [1b] | With V cam | | 2 |
| | | | Nº |
| 1 | E | | 260275 |
| 1 | V | | 260272 |

| | | |
|--|--|---|
| [2a] VT espagnolette → <i>from page 146</i> | | 1 |
| Alternatively: | | |
| [2b] VT espagnolette, lockable → <i>from page 146</i> | | |

| Espagnolette extension, (SRH > 1401 mm; not sh.) | | | | |
|--|---|---|---|--------|
| | | | | Nº |
| 200 | Y | - | - | 308267 |
| 400 | Y | - | - | 297858 |

Size-specific combinations:

| | | | | |
|-------------|--------|---|---|--------|
| | | | | Nº |
| ≤ 1400 | - | - | - | - |
| 1401 – 1600 | 200 KU | - | - | 308267 |
| 1601 – 2000 | - | - | - | - |
| 2001 – 2200 | 200 KU | - | - | 308267 |
| 2201 – 2400 | 400 KU | - | - | 297858 |
| 2401 – 2500 | 200 KU | - | - | 308267 |

Centre lock (CL)

| [5] CL component, horizontal | | | | |
|-------------------------------------|---|---|---|--------|
| | | | | Nº |
| 200 | - | - | - | 308267 |
| 344 | 1 | V | | 572665 |
| 480 | - | - | | 245729 |
| 590 | - | - | | 603442 |
| 790 | 1 | E | | 603444 |
| 990 | 1 | E | | 603447 |
| 1190 | 1 | E | | 603462 |
| 1440 | 1 | E | | 603466 |

Size-specific combinations:

| | | | | |
|-------------|------|---|---|--------|
| | | | | Nº |
| ≤ 760 | 344 | 1 | V | 572665 |
| 761 – 860 | 480 | - | - | 245729 |
| 861 – 1060 | 590 | - | - | 603442 |
| 1061 – 1260 | 790 | 1 | E | 603444 |
| 1261 – 1460 | 990 | 1 | E | 603447 |
| 1461 – 1660 | 1190 | 1 | E | 603462 |
| 1661 – 1910 | 1440 | 1 | E | 603466 |

| | | | | |
|--------|------|---|---|--------|
| | | | | Nº |
| ≥ 1911 | 1440 | 1 | E | 603466 |
| | 200 | - | - | 308267 |

| [6] Centre lock component 130, horizontal | | | | |
|--|---|---|---|--------|
| | | | | Nº |
| 130 | Y | 1 | E | 764350 |

| [7] CL component, vertical, on the mullion | | | | |
|---|---|---|---|--------|
| | | | | Nº |
| 200 | Y | - | - | 308267 |
| | Y | 1 | E | 450821 |
| 400 | Y | - | - | 297858 |
| 600 | Y | 1 | E | 255282 |
| | N | 1 | E | 255281 |

Size-specific combinations:

| | | | | |
|-------------|--------|---|---|--------|
| | | | | Nº |
| 1201 – 1800 | 600 | 1 | E | 255281 |
| 1801 – 2000 | 200 KU | - | - | 308267 |
| | 600 | 1 | E | 255281 |
| 2001 – 2200 | 400 KU | - | - | 297858 |
| | 600 | 1 | E | 255281 |
| 2201 – 2400 | 200 KU | 1 | E | 450821 |
| | 400 KU | - | - | 297858 |
| | 600 | 1 | E | 255281 |
| 2401 – 2500 | 200 KU | - | - | 308267 |
| | 600 KU | 1 | E | 255282 |
| | 200 KU | - | - | 308267 |
| | 600 | 1 | E | 255281 |

| [8] Roller track | |
|-------------------------|--------|
| | Nº |
| 3200 | 782919 |
| 6400 | 782920 |

| [9] Roller unit | | |
|------------------------|-------|--------|
| | | Nº |
| 41 | Left | 821686 |
| | Right | 823733 |

| | | |
|--------|--|---|
| | | |
| < 1060 | | 2 |
| ≥ 1060 | | 3 |

| [10] Control unit, on the mullion side and in the centre → <i>from page 158</i> | | |
|--|-------|--------|
| Alternatively (on the mullion side): | | |
| Control unit set with Soft function (incl. activator) → <i>from page 158</i> | | |
| | | Nº |
| 41 | Left | 821685 |
| | Right | 823730 |

[*] Control unit set with Soft function, on the locking side → *from page 158*  1
Alternatively:
[10] Control unit 

Contents:



| [*] |  | # |
|------|---|---|
| [29] | Activator | 1 |
| [30] | Control unit with Soft function | 1 |

[11] Centre closer, adjustable

|  |  | Nº |
|---|---|--------|
| 41 | Left | 823751 |
| | Right | 823752 |

|  |  |
|---|---|
| ≤ 1200 | 2 |
| 1201 – 2400 | 3 |
| > 2400 | 4 |

[12] MUL locking cam, adjustable

|  |  | Nº |
|---|---|--------|
| Gasket compression adjustable | 25 | 895955 |
| | 26 | 895966 |
| | 27 | 895970 |
| | 32 | 786728 |
| | 35.5 | 858628 |
| | 36 | 895972 |
| | 39.5 | 839047 |
| | 42 | 861550 |
| | 44 | 895973 |
| | 45.8 | 791838 |
| | 47.8 | 788696 |
| | 49 | 895974 |
| | 53.5 | 839045 |

|  |  |
|---|---|
| ≤ 1200 | 2 |
| 1201 – 2400 | 3 |
| > 2400 | 4 |

[14] Guide track  1

|  | Nº |
|---|--------|
| 3200 | 782921 |
| 6400 | 782922 |

[15] Striker to prevent incorrect operation  1

|  | Nº |
|---|--------|
| Striker to prevent incorrect operation | 822789 |

[16] Handle (200 mm handle length) → CTL_1  1

Recessed grip (43 mm distance), not sh. →  1
CTL_1

[17] Striker

|  |  | Nº |
|---|---|--------|
| Screw-on | – | 744579 |
| Can be routed in | Left | 798224 |
| | Right | 798245 |



|  |  |
|---|---|
| ≤ 1200 | 2 |
| 1201 – 2400 | 3 |
| > 2400 | 4 |

[18] Buffer  2



|  | Nº |
|---|--------|
| 14 | 635307 |

[20] MUL striker

|  | Nº |
|---|--------|
| Screw-on | 793493 |
| Can be routed in | 798223 |

|  |  |
|---|---|
| ≤ 1200 | 2 |
| 1201 – 2400 | 3 |
| > 2400 | 4 |



[21] Cover cap for MUL striker, only in combination with MUL striker, screw-on.

|  |  | Nº |
|---|--|--------|
| R01.1 | Natural silver | 819632 |
| R05.3 | Medium bronze | 819631 |
| R06.2 | Jet black | 798979 |
| R07.2 | Traffic white | 808054 |



|  |  |
|---|---|
| ≤ 1200 | 2 |
| 1201 – 2400 | 3 |
| > 2400 | 4 |

[31] End stop, profile-related  1

Alternatively:
[37] Rubber buffer → *from page 160*

|  |  |  | Nº |
|---|--|---|---------|
| End stop | RAL 7004 | Signal grey | 2006569 |
| | RAL 9005 | Jet black | 349600 |

[32] End stop packer, profile-related

|  |  |  | Nº |
|---|--|---|---------|
| Packer | RAL 7004 | Signal grey | 2007421 |
| | RAL 9005 | Jet black | 477263 |



[33] Stopper, cannot be used in conjunction with a control unit with SoftOpen and SoftStop on the mullion.  1
 Alternatively:
[37] Rubber buffer → *from page 160*

| | |
|---|--------|
|  | Nº |
| Stopper | 800196 |

[34] Packer; profile-related quantity ^[1]

| | |
|---|--------|
|  | Nº |
| Packer | 800197 |

Optional

[35] Brush holder

| | |
|---|--------|
|  | Nº |
| Brush holder | 809520 |

| | |
|---|---|
|  |  |
| < 1060 | 2 |
| ≥ 1060 | 3 |

[1] Only use the number of packers that is specified in the profile assessment.

4.1.2 Diagram A', K'

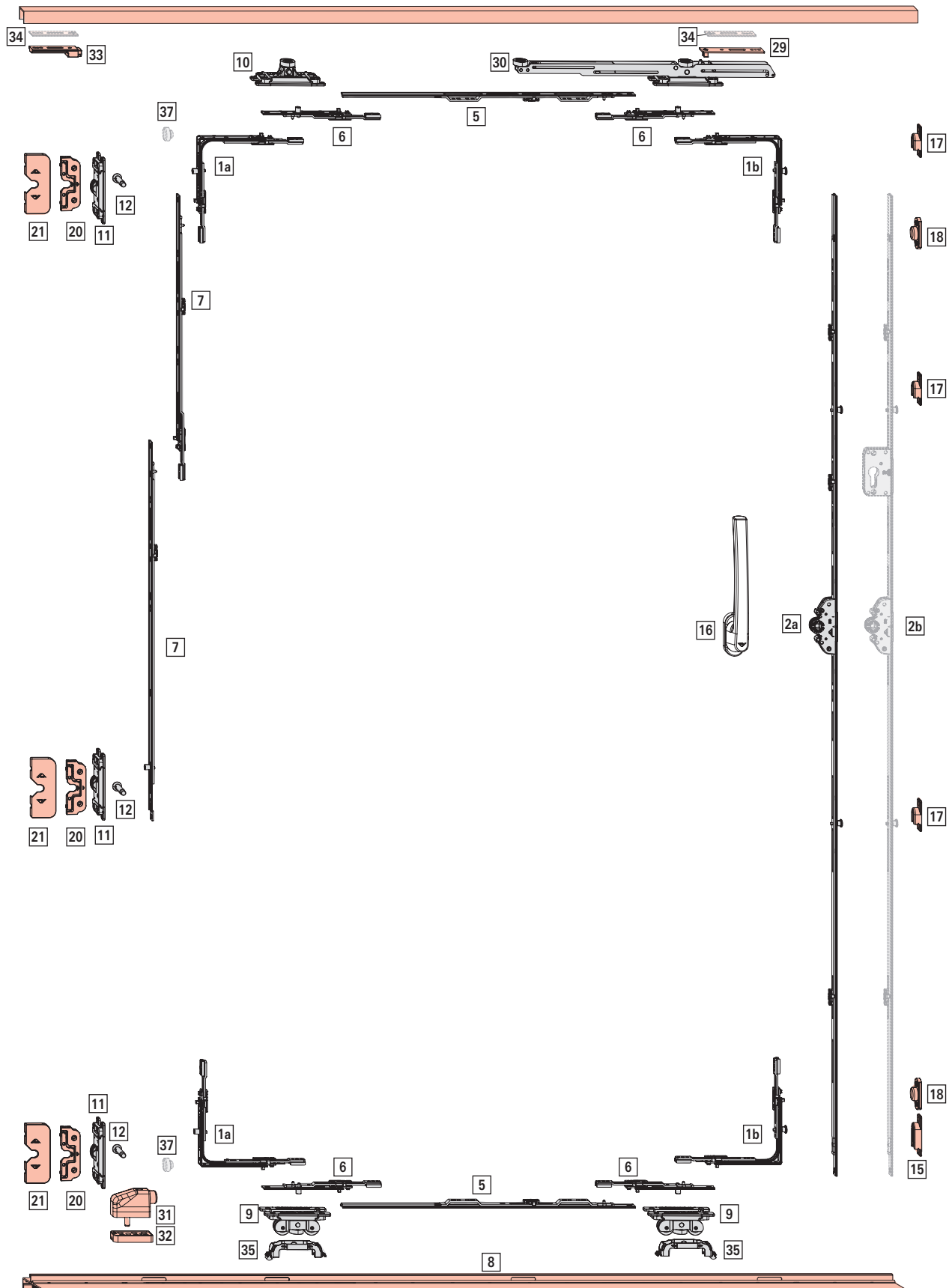



Application range

SRW: 710 – 2000 mm

SRH: 600 – 2500 mm

S.kg: max. 250 kg

| | | | |
|--------------------------|------------|--|--------|
| [1a] Corner drive | With E cam | | 2 |
| [1b] | With V cam | | 2 |
| | | | Nº |
| 1 | E | | 260275 |
| 1 | V | | 260272 |

| | | |
|--|--|---|
| [2a] VT espagnolette → <i>from page 146</i> | | 1 |
| Alternatively: | | |
| [2b] VT espagnolette, lockable → <i>from page 146</i> | | |

| Espagnolette extension, (SRH > 1401 mm; not sh.) | | | | |
|--|---|---|---|--------|
| | | | | Nº |
| 200 | Y | - | - | 308267 |
| 400 | Y | - | - | 297858 |

Size-specific combinations:

| | | | |
|-------------|--------|---|--------|
| | | | Nº |
| ≤ 1400 | - | - | - |
| 1401 – 1600 | 200 KU | - | 308267 |
| 1601 – 2000 | - | - | - |
| 2001 – 2200 | 200 KU | - | 308267 |
| 2201 – 2400 | 400 KU | - | 297858 |
| 2401 – 2500 | 200 KU | - | 308267 |

Centre lock (CL)

| [5] CL component, horizontal | | | |
|------------------------------|---|---|--------|
| | | | Nº |
| 200 | - | - | 308267 |
| 344 | 1 | V | 572665 |
| 480 | - | - | 245729 |
| 590 | - | - | 603442 |
| 790 | 1 | E | 603444 |
| 990 | 1 | E | 603447 |
| 1190 | 1 | E | 603462 |
| 1440 | 1 | E | 603466 |

Size-specific combinations:

| | | | | |
|-------------|------|---|----|--------|
| | | | Nº | |
| ≤ 760 | 344 | 1 | V | 572665 |
| 761 – 860 | 480 | - | - | 245729 |
| 861 – 1060 | 590 | - | - | 603442 |
| 1061 – 1260 | 790 | 1 | E | 603444 |
| 1261 – 1460 | 990 | 1 | E | 603447 |
| 1461 – 1660 | 1190 | 1 | E | 603462 |
| 1661 – 1910 | 1440 | 1 | E | 603466 |

| | | | | |
|--------|------|---|----|--------|
| | | | Nº | |
| ≥ 1911 | 1440 | 1 | E | 603466 |
| | 200 | - | - | 308267 |

| [6] Centre lock component 130, horizontal | | | | |
|---|---|---|---|--------|
| | | | | Nº |
| 130 | Y | 1 | E | 764350 |

| [7] CL component, vertical, on the mullion | | | | |
|--|---|---|---|--------|
| | | | | Nº |
| 200 | Y | - | - | 308267 |
| | Y | 1 | E | 450821 |
| 400 | Y | - | - | 297858 |
| 600 | Y | 1 | E | 255282 |
| | N | 1 | E | 255281 |

Size-specific combinations:

| | | | | |
|-------------|--------|---|----|--------|
| | | | Nº | |
| 1201 – 1800 | 600 | 1 | E | 255281 |
| 1801 – 2000 | 200 KU | - | - | 308267 |
| | 600 | 1 | E | 255281 |
| 2001 – 2200 | 400 KU | - | - | 297858 |
| | 600 | 1 | E | 255281 |
| 2201 – 2400 | 200 KU | 1 | E | 450821 |
| | 400 KU | - | - | 297858 |
| | 600 | 1 | E | 255281 |
| 2401 – 2500 | 200 KU | - | - | 308267 |
| | 600 KU | 1 | E | 255282 |
| | 200 KU | - | - | 308267 |
| | 600 | 1 | E | 255281 |

| [8] Roller track | |
|------------------|--------|
| | Nº |
| 3200 | 807733 |
| 6400 | 807734 |

| [9] Roller unit | | |
|-----------------|-------|--------|
| | | Nº |
| 41 | Left | 821686 |
| | Right | 823733 |

| | |
|--------|---|
| | |
| < 1060 | 2 |
| ≥ 1060 | 3 |



INFO

DIN L: order right components.

DIN R: order left components.

| [10] Control unit, on the mullion side and in the centre → <i>from page 158</i> | |
|---|-----|
| | 1-2 |
| Alternatively (on the mullion side): | |



Control unit set with Soft function (incl. activator) → from page 158 

| |  |  | Nº |
|----|---|---|--------|
| 41 | | Left | 821685 |
| | | Right | 823730 |



INFO

DIN L: order right components.

DIN R: order left components.

[*] Control unit set with Soft function, on the locking side → from page 158 

Alternatively:

[10] Control unit

Contents:

| [*] |  | # |
|------|---|---|
| [29] | Activator | 1 |
| [30] | Control unit with Soft function | 1 |





INFO

DIN L: order right components.



DIN R: order left components.



[11] Centre closer, adjustable

| |  |  | Nº |
|----|---|---|--------|
| 41 | | Left | 823751 |
| | | Right | 823752 |

| |  |  |
|-------------|---|---|
| ≤ 1200 | 2 | |
| 1201 – 2400 | 3 | |
| > 2400 | 4 | |

[12] MUL locking cam, adjustable

|  |  | Nº |
|---|---|--------|
| Gasket compression adjustable | 25 | 895955 |
| | 26 | 895966 |
| | 27 | 895970 |
| | 32 | 786728 |
| | 35.5 | 858628 |
| | 36 | 895972 |
| | 39.5 | 839047 |
| | 42 | 861550 |
| | 44 | 895973 |
| | 45.8 | 791838 |
| | 47.8 | 788696 |
| | 49 | 895974 |
| | 53.5 | 839045 |

| |  |  |
|--------|---|---|
| ≤ 1200 | 2 | |



| |  |  |
|-------------|---|---|
| 1201 – 2400 | 3 | |
| > 2400 | 4 | |

[14] Guide track 

| |  | Nº |
|------|---|--------|
| 3200 | | 782921 |
| 6400 | | 782922 |

[15] Striker to prevent incorrect operation 

| |  | Nº |
|--|---|--------|
| Striker to prevent incorrect operation | | 822789 |

[16] Handle (200 mm handle length) → CTL_1 
 Recessed grip (43 mm distance), not sh. → CTL_1 

[17] Striker

| |  |  | Nº |
|------------------|---|---|--------|
| Screw-on | – | | 744579 |
| Can be routed in | | Left | 798224 |
| | | Right | 798245 |



| |  |  |
|-------------|---|---|
| ≤ 1200 | 2 | |
| 1201 – 2400 | 3 | |
| > 2400 | 4 | |

[18] Buffer 

| |  | Nº |
|----|---|--------|
| 14 | | 635307 |



[20] MUL striker

| |  | Nº |
|------------------|---|--------|
| Screw-on | | 793493 |
| Can be routed in | | 798223 |

| |  |  |
|-------------|---|---|
| ≤ 1200 | 2 | |
| 1201 – 2400 | 3 | |
| > 2400 | 4 | |

[21] Cover cap for MUL striker, only in combination with MUL striker, screw-on.

| |  | Nº |
|-------|--|--------|
| R01.1 | Natural silver | 819632 |
| R05.3 | Medium bronze | 819631 |
| R06.2 | Jet black | 798979 |
| R07.2 | Traffic white | 808054 |



| |  |  |
|-------------|---|---|
| ≤ 1200 | 2 | |
| 1201 – 2400 | 3 | |
| > 2400 | 4 | |





[31] End stop, profile-related  1

Alternatively:

[37] Rubber buffer → *from page 160*

| | | | |
|---|---|---|---------|
|  |  |  | Nº |
| End stop | RAL 7004 | Signal grey | 2006569 |
| | RAL 9005 | Jet black | 349600 |

[32] End stop packer, profile-related

| | | | |
|---|---|---|---------|
|  |  |  | Nº |
| Packer | RAL 7004 | Signal grey | 2007421 |
| | RAL 9005 | Jet black | 477263 |

[33] Stopper, cannot be used in conjunction  1

with a control unit with SoftOpen and SoftStop on the mullion.

Alternatively:

[37] Rubber buffer → *from page 160*

| | |
|---|--------|
|  | Nº |
| Stopper | 800196 |

[34] Packer; profile-related quantity ^[2]

| | |
|--|--------|
|  | Nº |
| Packer | 800197 |

[35] Brush holder

| | |
|---|--------|
|  | Nº |
| Brush holder | 809520 |

| | |
|---|---|
|  |  |
| < 1060 | 2 |
| ≥ 1060 | 3 |

[2] Only use the number of packers that is specified in the profile assessment.

4.1.3 Diagram C

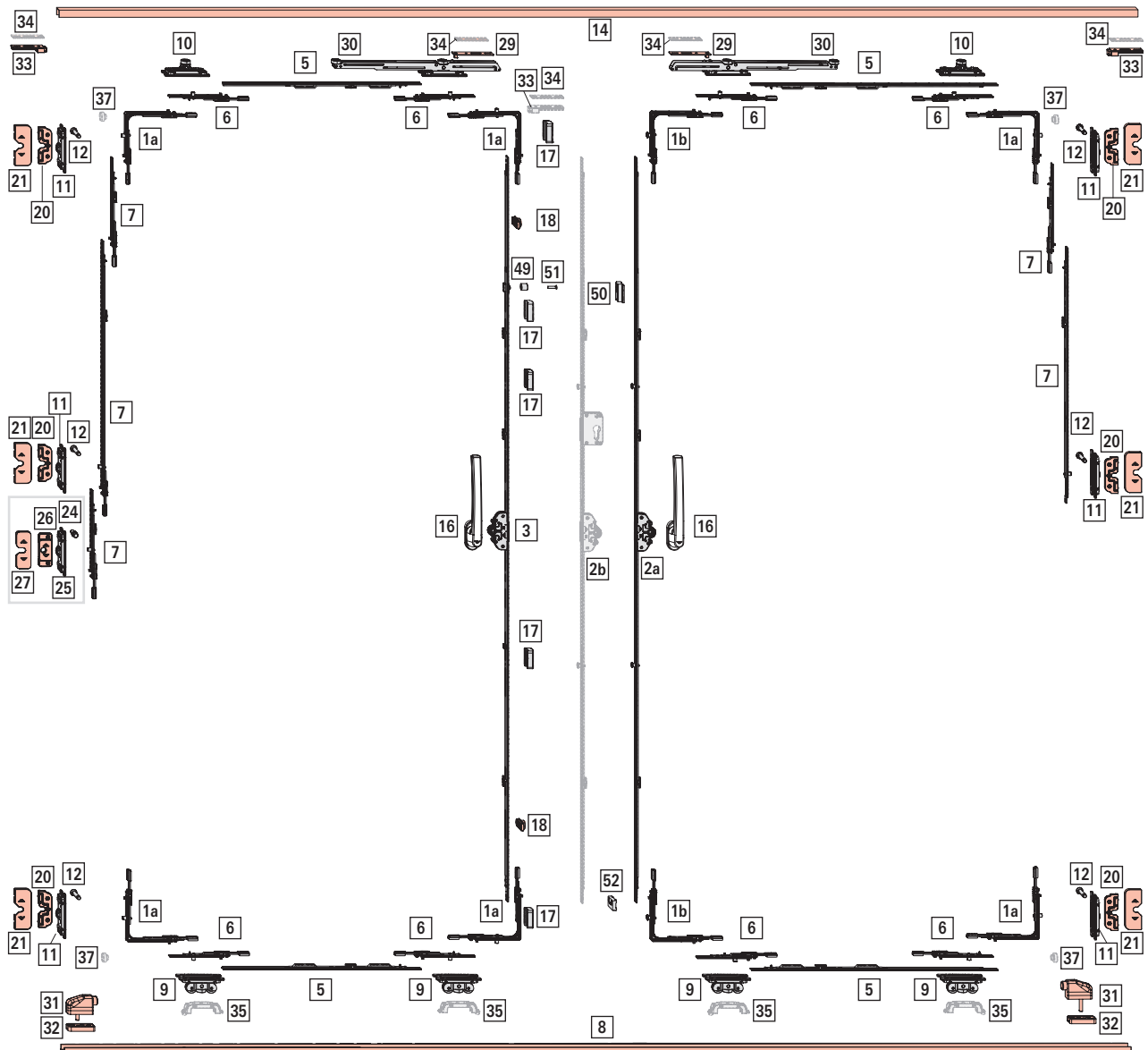



Application range

SRW: 710 – 1500 mm

SRH: 600 – 2500 mm

S.kg: max. 250 kg

[1a] Corner drive With E cam 6

[1b] With V cam 2

| | | Nº |
|---|---|--------|
| 1 | E | 260275 |
| 1 | V | 260272 |

[2a] VT espagnolette → from page 146 1

Alternatively:

[2b] VT espagnolette, lockable → from page 146

[3] VT espagnolette, second opening sash → 1
from page 146

Espagnolette extension, (SRH > 1401 mm; not sh.)

| | | | | Nº |
|-----|---|---|---|--------|
| 200 | Y | – | – | 308267 |
| 400 | Y | – | – | 297858 |

Size-specific combinations:

| | | | | Nº |
|-------------|--------|---|---|--------|
| ≤ 1400 | – | – | – | – |
| 1401 – 1600 | 200 KU | – | – | 308267 |
| 1601 – 2000 | – | – | – | – |
| 2001 – 2200 | 200 KU | – | – | 308267 |
| 2201 – 2400 | 400 KU | – | – | 297858 |
| 2401 – 2500 | 200 KU | – | – | 308267 |

Centre lock (CL)

[5] CL component, horizontal

| | | | Nº |
|------|---|---|--------|
| 200 | – | – | 308267 |
| 344 | 1 | V | 572665 |
| 480 | – | – | 245729 |
| 590 | – | – | 603442 |
| 790 | 1 | E | 603444 |
| 990 | 1 | E | 603447 |
| 1190 | 1 | E | 603462 |
| 1440 | 1 | E | 603466 |

Size-specific combinations:

First or second opening sash

| | | | | Nº |
|-------------|-----|---|---|--------|
| ≤ 760 | 344 | 1 | V | 572665 |
| 761 – 860 | 480 | – | – | 245729 |
| 861 – 1060 | 590 | – | – | 603442 |
| 1061 – 1260 | 790 | 1 | E | 603444 |

| | | | | Nº |
|-------------|------|---|---|--------|
| 1261 – 1460 | 990 | 1 | E | 603447 |
| 1461 – 1660 | 1190 | 1 | E | 603462 |
| 1661 – 1910 | 1440 | 1 | E | 603466 |
| ≥ 1911 | 1440 | 1 | E | 603466 |
| | 200 | – | – | 308267 |

[6] Centre lock component 130, horizontal and vertical 8

| | | | | Nº |
|-----|---|---|---|--------|
| 130 | Y | 1 | E | 764350 |

[7] CL component, vertical, on the mullion

| | | | | Nº |
|-----|---|---|---|--------|
| 200 | Y | – | – | 308267 |
| | Y | 1 | E | 450821 |
| 400 | Y | – | – | 297858 |
| 600 | Y | 1 | E | 255282 |
| | N | 1 | E | 255281 |





Size-specific combinations:

First opening sash:

| | | | | Nº |
|-------------|--------|---|---|--------|
| 1201 – 1800 | 600 | 1 | E | 255281 |
| 1801 – 2000 | 200 KU | – | – | 308267 |
| | 600 | 1 | E | 255281 |
| 2001 – 2200 | 400 KU | – | – | 297858 |
| | 600 | 1 | E | 255281 |
| 2201 – 2400 | 200 KU | 1 | E | 450821 |
| | 400 KU | – | – | 297858 |
| | 600 | 1 | E | 255281 |
| 2401 – 2500 | 200 KU | – | – | 308267 |
| | 600 KU | 1 | E | 255282 |
| | 200 KU | – | – | 308267 |
| | 600 | 1 | E | 255281 |

Second opening sash:

| | | | | Nº |
|-------------|--------|---|---|--------|
| 600 – 1200 | 200 KU | 1 | E | 450821 |
| 1201 – 1800 | 600 KU | 1 | E | 255282 |
| | 200 KU | 1 | E | 450821 |
| 1801 – 2000 | 200 KU | – | – | 308267 |
| | 600 KU | 1 | E | 255282 |
| | 200 KU | 1 | E | 450821 |
| 2001 – 2200 | 400 KU | – | – | 297858 |
| | 600 KU | 1 | E | 255282 |
| | 200 KU | 1 | E | 450821 |
| 2201 – 2400 | 200 KU | 1 | E | 450821 |
| | 400 KU | – | – | 297858 |
| | 600 KU | 1 | E | 255282 |
| | 200 KU | 1 | E | 450821 |



|  |  |  |  | Nº |
|---|---|---|---|--------|
| 2401 – 2500 | 200 KU | – | – | 308267 |
| | 600 KU | 1 | E | 255282 |
| | 200 KU | – | – | 308267 |
| | 600 KU | 1 | E | 255282 |
| | 200 KU | 1 | E | 450821 |



[8] Roller track  1-2

|  | Nº |
|---|--------|
| 3200 | 782919 |
| 6400 | 782920 |

[9] Roller unit

|  |  | Nº |
|---|---|--------|
| 41 | Left | 821686 |
| | Right | 823733 |



|  |  |
|---|---|
| < 1060 | 4 |
| ≥ 1060 | 6 |

[10] Control unit, on the mullion side and in the centre → from page 158  2-4
 Alternatively (on the mullion side):
 Control unit set with Soft function (incl. activator) → from page 158  1-2

|  |  | Nº |
|---|---|--------|
| 41 | Left | 821685 |
| | Right | 823730 |



[*] Control unit set with Soft function, on the locking side → from page 158  2
 Alternatively:
 [10] Control unit

Contents:

|  |  | # |
|---|---|---|
| [29] | Activator | 1 |
| [30] | Control unit with Soft function | 1 |

[11] Centre closer, adjustable

|  |  | Nº |
|---|---|--------|
| 41 | Left | 823751 |
| | Right | 823752 |

|  |  |
|---|---|
| ≤ 1200 | 4 |
| 1201 – 2400 | 6 |
| > 2400 | 8 |



[12] MUL locking cam, adjustable

|  |  | Nº |
|---|---|--------|
| Gasket compression adjustable | 25 | 895955 |
| | 26 | 895966 |
| | 27 | 895970 |
| | 32 | 786728 |
| | 35.5 | 858628 |
| | 36 | 895972 |
| | 39.5 | 839047 |
| | 42 | 861550 |
| | 44 | 895973 |
| | 45.8 | 791838 |
| | 47.8 | 788696 |
| | 49 | 895974 |
| | 53.5 | 839045 |

|  |  |
|---|---|
| ≤ 1200 | 4 |
| 1201 – 2400 | 6 |
| > 2400 | 8 |

[14] Guide track  1-2

|  | Nº |
|--|--------|
| 3200 | 782921 |
| 6400 | 782922 |

[16] Handle (200 mm handle length) → CTL_1  2
Recessed grip (43 mm distance), not sh. → CTL_1  2

[17] Striker, diagram C

|  | Nº |
|---|--------|
| Screw-on | 806824 |



|  |  |
|---|---|
| ≤ 1200 | 2 |
| 1201 – 2400 | 3 |
| > 2400 | 4 |

[18] Buffer  2

|  | Nº |
|---|--------|
| 14 | 635307 |

[20] MUL striker

|  | Nº |
|---|--------|
| Screw-on | 793493 |
| Can be routed in | 798223 |

|  |  |
|---|---|
| ≤ 1200 | 4 |
| 1201 – 2400 | 6 |
| > 2400 | 8 |



[21] Cover cap for MUL striker, only in combination with MUL striker, screw-on.

| | | | N ^o |
|-------|----------------|--|----------------|
| R01.1 | Natural silver | | 819632 |
| R05.3 | Medium bronze | | 819631 |
| R06.2 | Jet black | | 798979 |
| R07.2 | Traffic white | | 808054 |

| ≤ 1200 | 4 |
|-------------|---|
| 1201 – 2400 | 6 |
| > 2400 | 8 |

[24] Pin, adjustable, for anti-pushback function

| | | N ^o |
|-------------------------------|------|----------------|
| Gasket compression adjustable | 25 | 895977 |
| | 26 | 895984 |
| | 27 | 895989 |
| | 32 | 895994 |
| | 35.5 | 858629 |
| | 36 | 895999 |
| | 39.5 | 839049 |
| | 42 | 861551 |
| | 44 | 896002 |
| | 49 | 896005 |
| | 53.5 | 839048 |

[25] Centre closer, adjustable, for anti-pushback function

| | | N ^o |
|----|-------|----------------|
| 41 | Left | 823751 |
| | Right | 823752 |



INFO

DIN L: order right components.

DIN R: order left components.

[26] Striker for anti-pushback function

| | N ^o |
|------------------------------------|----------------|
| Striker for anti-pushback function | 810279 |

[27] Cover cap for striker for anti-pushback function

| | | | N ^o |
|-------|----------------|--|----------------|
| R01.1 | Natural silver | | 828482 |
| R05.3 | Medium bronze | | 828483 |
| R06.2 | Jet black | | 809717 |
| R07.2 | Traffic white | | 819351 |

[31] End stop, profile-related

Alternatively:

[37] Rubber buffer → from page 160

| | | | N ^o |
|----------|----------|-------------|----------------|
| End stop | RAL 7004 | Signal grey | 2006569 |
| | RAL 9005 | Jet black | 349600 |

[32] End stop packer, profile-related

| | | | N ^o |
|--------|----------|-------------|----------------|
| Packer | RAL 7004 | Signal grey | 2007421 |
| | RAL 9005 | Jet black | 477263 |

[33] Stopper, cannot be used in conjunction with a control unit with SoftOpen / SoftClose together with SoftStop on the mullion side / SoftStop on the locking side.

Alternatively:

[37] Rubber buffer → from page 160

| | N ^o |
|---------|----------------|
| Stopper | 800196 |

[34] Packer; profile-related quantity ^[3]

| | N ^o |
|--------|----------------|
| Packer | 800197 |

[*] Operating sequence control set

SRH ≥ 1200 mm, profile-related

| | N ^o |
|--------|----------------|
| Timber | 861110 |

Contents:

| | | | | # |
|------|----------------------------|--|--|---|
| [49] | Bolt | | | 1 |
| [50] | Stop | | | 1 |
| [51] | Countersunk screw, M5 x 20 | | | 1 |
| [52] | Anti-lifting device | | | 1 |

Optional

[33] Stopper, cannot be used in conjunction with a control unit with SoftOpen and SoftStop on the mullion side.

| | N ^o |
|---------|----------------|
| Stopper | 800196 |

[34] Packer; profile-related quantity ^[4]

| | N ^o |
|--------|----------------|
| Packer | 800197 |

[3] Only use the number of packers that is specified in the profile assessment.

[4] Only use the number of packers that is specified in the profile assessment.

[35] Brush holder



Nº

Brush holder 809520



< 1060 4

≥ 1060 6



4.1.4 Diagram C'

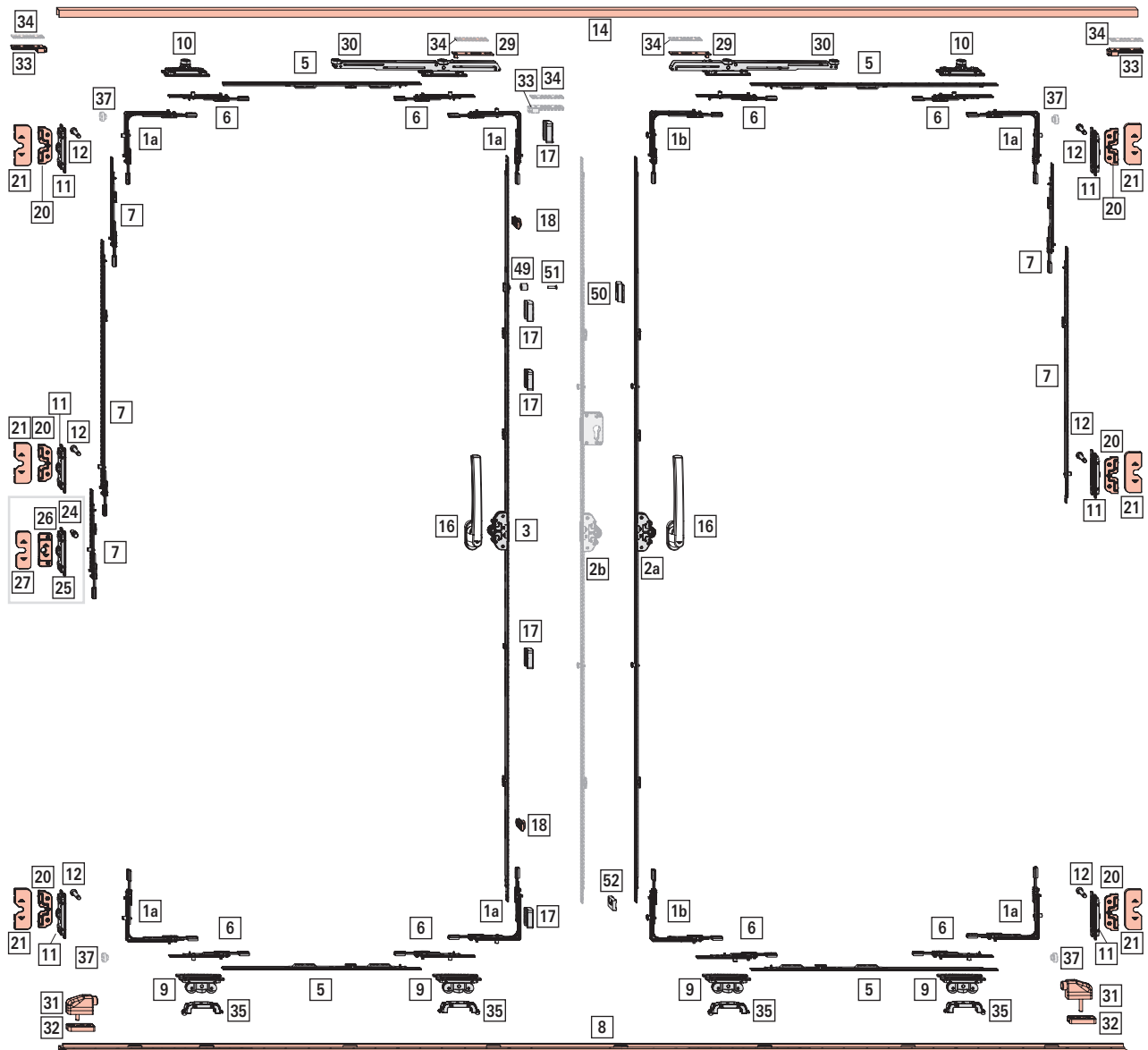



Application range

SRW: 710 – 1500 mm

SRH: 600 – 2500 mm

S.kg: max. 250 kg

| | | | |
|--------------------------|------------|--|-----------|
| [1a] Corner drive | With E cam | | 6 |
| [1b] | With V cam | | 2 |
| | | | Nº |
| 1 | E | | 260275 |
| 1 | V | | 260272 |

| | | |
|---|--|---|
| [2a] VT espagnolette → from page 146 | | 1 |
| Alternatively: | | |
| [2b] VT espagnolette, lockable → from page 146 | | |

| | | |
|---|--|---|
| [3] VT espagnolette, second opening sash → | | 1 |
| from page 146 | | |

| | | | | |
|--|---|---|---|-----------|
| Espagnolette extension, (SRH > 1401 mm; not sh.) | | | | |
| | | | | Nº |
| 200 | Y | – | – | 308267 |
| 400 | Y | – | – | 297858 |

Size-specific combinations:

| | | | | |
|-------------|--------|---|---|-----------|
| | | | | Nº |
| ≤ 1400 | – | – | – | – |
| 1401 – 1600 | 200 KU | – | – | 308267 |
| 1601 – 2000 | – | – | – | – |
| 2001 – 2200 | 200 KU | – | – | 308267 |
| 2201 – 2400 | 400 KU | – | – | 297858 |
| 2401 – 2500 | 200 KU | – | – | 308267 |

Centre lock (CL)

| | | | | |
|-------------------------------------|---|---|---|-----------|
| [5] CL component, horizontal | | | | |
| | | | | Nº |
| 200 | – | – | – | 308267 |
| 344 | 1 | V | – | 572665 |
| 480 | – | – | – | 245729 |
| 590 | – | – | – | 603442 |
| 790 | 1 | E | – | 603444 |
| 990 | 1 | E | – | 603447 |
| 1190 | 1 | E | – | 603462 |
| 1440 | 1 | E | – | 603466 |

Size-specific combinations:

First or second opening sash

| | | | | |
|-------------|-----|---|---|-----------|
| | | | | Nº |
| ≤ 760 | 344 | 1 | V | 572665 |
| 761 – 860 | 480 | – | – | 245729 |
| 861 – 1060 | 590 | – | – | 603442 |
| 1061 – 1260 | 790 | 1 | E | 603444 |

| | | | | |
|-------------|------|---|---|-----------|
| | | | | Nº |
| 1261 – 1460 | 990 | 1 | E | 603447 |
| 1461 – 1660 | 1190 | 1 | E | 603462 |
| 1661 – 1910 | 1440 | 1 | E | 603466 |
| ≥ 1911 | 1440 | 1 | E | 603466 |
| | 200 | – | – | 308267 |

| | | | | |
|---|---|---|---|-----------|
| [6] Centre lock component 130, horizontal and vertical | | | | |
| | | | | Nº |
| 130 | Y | 1 | E | 764350 |

| | | | | |
|---|---|---|---|-----------|
| [7] CL component, vertical, on the mullion | | | | |
| | | | | Nº |
| 200 | Y | – | – | 308267 |
| | Y | 1 | E | 450821 |
| 400 | Y | – | – | 297858 |
| 600 | Y | 1 | E | 255282 |
| | N | 1 | E | 255281 |



Size-specific combinations:

First opening sash:

| | | | | |
|-------------|--------|---|---|-----------|
| | | | | Nº |
| 1201 – 1800 | 600 | 1 | E | 255281 |
| 1801 – 2000 | 200 KU | – | – | 308267 |
| | 600 | 1 | E | 255281 |
| 2001 – 2200 | 400 KU | – | – | 297858 |
| | 600 | 1 | E | 255281 |
| 2201 – 2400 | 200 KU | 1 | E | 450821 |
| | 400 KU | – | – | 297858 |
| | 600 | 1 | E | 255281 |
| 2401 – 2500 | 200 KU | – | – | 308267 |
| | 600 KU | 1 | E | 255282 |
| | 200 KU | – | – | 308267 |
| | 600 | 1 | E | 255281 |

Second opening sash:

| | | | | |
|-------------|--------|---|---|-----------|
| | | | | Nº |
| 600 – 1200 | 200 KU | 1 | E | 450821 |
| 1201 – 1800 | 600 KU | 1 | E | 255282 |
| | 200 KU | 1 | E | 450821 |
| 1801 – 2000 | 200 KU | – | – | 308267 |
| | 600 KU | 1 | E | 255282 |
| | 200 KU | 1 | E | 450821 |
| 2001 – 2200 | 400 KU | – | – | 297858 |
| | 600 KU | 1 | E | 255282 |
| | 200 KU | 1 | E | 450821 |
| 2201 – 2400 | 200 KU | 1 | E | 450821 |
| | 400 KU | – | – | 297858 |
| | 600 KU | 1 | E | 255282 |
| | 200 KU | 1 | E | 450821 |

|  |  |  |  | N ^o |
|---|---|---|---|----------------|
| 2401 – 2500 | 200 KU | – | – | 308267 |
| | 600 KU | 1 | E | 255282 |
| | 200 KU | – | – | 308267 |
| | 600 KU | 1 | E | 255282 |
| | 200 KU | 1 | E | 450821 |

[8] Roller track 

|  | N ^o |
|---|----------------|
| 3200 | 807733 |
| 6400 | 807734 |

[9] Roller unit

|  |  | N ^o |
|---|---|----------------|
| 41 | Left | 821686 |
| | Right | 823733 |

|  |  |
|---|---|
| < 1060 | 4 |
| ≥ 1060 | 6 |



INFO

DIN L: order right components.

DIN R: order left components.

[10] Control unit, on the mullion side and in the centre → from page 158 

Alternatively (on the mullion side):

Control unit set with Soft function (incl. activator) → from page 158 

|  |  | N ^o |
|---|---|----------------|
| 41 | Left | 821685 |
| | Right | 823730 |



INFO

DIN L: order right components.

DIN R: order left components.

[*] Control unit set with Soft function, on the locking side → from page 158 

Alternatively:

[10] Control unit

Contents:

|  |  | # |
|---|---|---|
| [29] | Activator | 1 |
| [30] | Control unit with Soft function | 1 |





INFO

DIN L: order right components.

DIN R: order left components.

[11] Centre closer, adjustable

|  |  | N ^o |
|---|---|----------------|
| 41 | Left | 823751 |
| | Right | 823752 |

|  |  |
|---|---|
| ≤ 1200 | 4 |
| 1201 – 2400 | 6 |
| > 2400 | 8 |



INFO

DIN L: order right components.

DIN R: order left components.



[12] MUL locking cam, adjustable

|  |  | N ^o |
|---|---|----------------|
| Gasket compression adjustable | 25 | 895955 |
| | 26 | 895966 |
| | 27 | 895970 |
| | 32 | 786728 |
| | 35.5 | 858628 |
| | 36 | 895972 |
| | 39.5 | 839047 |
| | 42 | 861550 |
| | 44 | 895973 |
| | 45.8 | 791838 |
| | 47.8 | 788696 |
| | 49 | 895974 |
| | 53.5 | 839045 |

|  |  |
|---|---|
| ≤ 1200 | 4 |
| 1201 – 2400 | 6 |
| > 2400 | 8 |



[14] Guide track 

|  | N ^o |
|---|----------------|
| 3200 | 782921 |
| 6400 | 782922 |

[16] Handle (200 mm handle length) → CTL_1 
Recessed grip (43 mm distance), not sh. → CTL_1 

[17] Striker, diagram C

|  | N ^o |
|---|----------------|
| Screw-on | 806824 |

|  |  |
|---|---|
| ≤ 1200 | 2 |
| 1201 – 2400 | 3 |
| > 2400 | 4 |



[18] Buffer  2

| | |
|---|--------|
|  | Nº |
| 14 | 635307 |

[20] MUL striker

| | |
|---|--------|
|  | Nº |
| Screw-on | 793493 |
| Can be routed in | 798223 |

| | |
|---|---|
|  |  |
| ≤ 1200 | 4 |
| 1201 – 2400 | 6 |
| > 2400 | 8 |

[21] Cover cap for MUL striker, only in combination with MUL striker, screw-on.

| | | |
|---|---|--------|
|  |  | Nº |
| R01.1 | Natural silver | 819632 |
| R05.3 | Medium bronze | 819631 |
| R06.2 | Jet black | 798979 |
| R07.2 | Traffic white | 808054 |

| | |
|--|--|
|  |  |
| ≤ 1200 | 4 |
| 1201 – 2400 | 6 |
| > 2400 | 8 |

[24] Pin, adjustable, for anti-pushback function  1

| | | |
|---|---|--------|
|  |  | Nº |
| Gasket compression adjustable | 25 | 895977 |
| | 26 | 895984 |
| | 27 | 895989 |
| | 32 | 895994 |
| | 35.5 | 858629 |
| | 36 | 895999 |
| | 39.5 | 839049 |
| | 42 | 861551 |
| | 44 | 896002 |
| | 49 | 896005 |
| | 53.5 | 839048 |

[25] Centre closer, adjustable, for anti-pushback function  1

| | | |
|---|---|--------|
|  |  | Nº |
| 41 | Left | 823751 |
| | Right | 823752 |

[26] Striker for anti-pushback function  1



| | |
|---|--------|
|  | Nº |
| Striker for anti-pushback function | 810279 |

[27] Cover cap for striker for anti-pushback function  1



| | | |
|---|--|--------|
|  |  | Nº |
| R01.1 | Natural silver | 828482 |
| R05.3 | Medium bronze | 828483 |
| R06.2 | Jet black | 809717 |
| R07.2 | Traffic white | 819351 |

[31] End stop, profile-related  2

Alternatively:
[37] Rubber buffer → *from page 160*

| | | | |
|---|--|---|---------|
|  |  |  | Nº |
| End stop | RAL 7004 | Signal grey | 2006569 |
| | RAL 9005 | Jet black | 349600 |

[32] End stop packer, profile-related

| | | | |
|---|--|---|---------|
|  |  |  | Nº |
| Packer | RAL 7004 | Signal grey | 2007421 |
| | RAL 9005 | Jet black | 477263 |

[33] Stopper, cannot be used in conjunction with a control unit with SoftOpen / SoftClose together with SoftStop on the mullion side / SoftStop on the locking side.  2

Alternatively:
[37] Rubber buffer → *from page 160*

| | |
|---|--------|
|  | Nº |
| Stopper | 800196 |

[34] Packer; profile-related quantity ^[5]

| | |
|---|--------|
|  | Nº |
| Packer | 800197 |

[*] Operating sequence control set SRH ≥ 1200 mm, profile-related  1

| | |
|---|--------|
|  | Nº |
| Timber | 861110 |

Contents:

| | | |
|------------|---|----------|
| [*] |  | # |
| [49] | Bolt | 1 |
| [50] | Stop | 1 |
| [51] | Countersunk screw, M5 x 20 | 1 |
| [52] | Anti-lifting device | 1 |

[35] Brush holder

| | |
|---|--------|
|  | Nº |
| Brush holder | 809520 |

| | |
|---|---|
|  |  |
| < 1060 | 4 |
| ≥ 1060 | 6 |

[5] Only use the number of packers that is specified in the profile assessment.

Optional

[33] Stopper, cannot be used in conjunction with a control unit with SoftOpen and SoftStop on the mullion side.  1



Nº

Stopper

800196

[34] Packer; profile-related quantity ^[6]



Nº

Packer

800197

[6] Only use the number of packers that is specified in the profile assessment.



4.2 PVC

4.2.1 aluplast | smart-slide

4.2.1.1 Diagram A, K





Application range

SRW: 710 – 2000 mm

SRH: 600 – 2500 mm

S.kg: max. 200 kg

| | | | |
|-------------------|------------|--|----------------|
| [1a] Corner drive | With E cam | | 2 |
| [1b] | With V cam | | 2 |
| | | | N ^o |
| 1 | E | | 260275 |
| 1 | V | | 260272 |

| | | | | | | | | |
|----------------------|-------------|------|-----|------|---|---|----------|----------------|
| [2a] VT espagnolette | | 1 | | | | | | |
| | | | | | | | | N ^o |
| 35 | 600 – 800 | 690 | 200 | 263 | – | – | Roto Sil | 799045 |
| | 801 – 1000 | 890 | 200 | 413 | – | – | Roto Sil | 798027 |
| | 1001 – 1200 | 1090 | 200 | 513 | 1 | V | Roto Sil | 798028 |
| | 1201 – 1600 | 1290 | 200 | 563 | 1 | V | Roto Sil | 798030 |
| | 1601 – 1800 | 1690 | 200 | 563 | 1 | V | Roto Sil | 798031 |
| | 1801 – 2400 | 1890 | 200 | 1000 | 2 | V | Roto Sil | 798032 |
| | 2401 – 2500 | 2290 | 200 | 1000 | 2 | V | Roto Sil | 798033 |

Espagnolette extension, (SRH > 1401 mm; not sh.)

| | | | | |
|-----|---|---|---|----------------|
| | | | | N ^o |
| 200 | Y | – | – | 308267 |
| 400 | Y | – | – | 297858 |

Size-specific combinations:

| | | | | |
|-------------|--------|---|---|----------------|
| | | | | N ^o |
| ≤ 1400 | – | – | – | – |
| 1401 – 1600 | 200 KU | – | – | 308267 |
| 1601 – 2000 | – | – | – | – |
| 2001 – 2200 | 200 KU | – | – | 308267 |
| 2201 – 2400 | 400 KU | – | – | 297858 |
| 2401 – 2500 | 200 KU | – | – | 308267 |

Centre lock (CL)

| | | | | |
|------------------------------|---|---|---|----------------|
| [5] CL component, horizontal | | | | N ^o |
| | | | | N ^o |
| 200 | – | – | – | 308267 |
| 344 | 1 | V | – | 572665 |
| 480 | – | – | – | 245729 |
| 590 | – | – | – | 603442 |
| 790 | 1 | E | – | 603444 |
| 990 | 1 | E | – | 603447 |
| 1190 | 1 | E | – | 603462 |
| 1440 | 1 | E | – | 603466 |

Size-specific combinations:

| | | | | |
|-------|-----|---|---|----------------|
| | | | | N ^o |
| ≤ 760 | 344 | 1 | V | 572665 |

| | | | | |
|-------------|------|---|---|----------------|
| | | | | N ^o |
| 761 – 860 | 480 | – | – | 245729 |
| 861 – 1060 | 590 | – | – | 603442 |
| 1061 – 1260 | 790 | 1 | E | 603444 |
| 1261 – 1460 | 990 | 1 | E | 603447 |
| 1461 – 1660 | 1190 | 1 | E | 603462 |
| 1661 – 1910 | 1440 | 1 | E | 603466 |
| ≥ 1911 | 1440 | 1 | E | 603466 |
| | 200 | – | – | 308267 |

| | | | | |
|---|---|---|---|----------------|
| [6] Centre lock component 130, horizontal | | 4 | | |
| | | | | N ^o |
| 130 | Y | 1 | E | 764350 |

| | | | | |
|--|---|---|---|----------------|
| [7] CL component, vertical, on the mullion | | | | N ^o |
| | | | | N ^o |
| 200 | Y | – | – | 308267 |
| | Y | 1 | E | 450821 |
| 400 | Y | – | – | 297858 |
| 600 | Y | 1 | E | 255282 |
| | N | 1 | E | 255281 |

Size-specific combinations:

| | | | | |
|-------------|--------|---|---|----------------|
| | | | | N ^o |
| 1201 – 1800 | 600 | 1 | E | 255281 |
| 1801 – 2000 | 200 KU | – | – | 308267 |
| | 600 | 1 | E | 255281 |
| 2001 – 2200 | 400 KU | – | – | 297858 |
| | 600 | 1 | E | 255281 |
| 2201 – 2400 | 200 KU | 1 | E | 450821 |
| | 400 KU | – | – | 297858 |
| | 600 | 1 | E | 255281 |
| 2401 – 2500 | 200 KU | – | – | 308267 |
| | 600 KU | 1 | E | 255282 |
| | 200 KU | – | – | 308267 |
| | 600 | 1 | E | 255281 |

| | | |
|-----------------|-------|----------------|
| [9] Roller unit | | N ^o |
| | | N ^o |
| 41 | Left | 821686 |
| | Right | 823733 |

| | | |
|--------|--|---|
| | | |
| < 1060 | | 2 |
| ≥ 1060 | | 3 |

[10] Control unit, on the mullion side and in the centre → *from page 158*
Alternatively (on the mullion side):
Control unit set with Soft function (incl. activator) → *from page 158*

| | | |
|----|-------|----------------|
| | | N ^o |
| 41 | Left | 821685 |
| | Right | 823730 |

[*] Control unit set with Soft function, on the locking side → *from page 158*  1
Alternatively:
[10] Control unit 

Contents:

| [*] |  | # |
|------|---|---|
| [29] | Activator | 1 |
| [30] | Control unit with Soft function | 1 |

[11] Centre closer

|  |  | Nº |
|---|---|--------|
| 41 | Left | 821687 |
| | Right | 823736 |

|  |  |
|---|---|
| ≤ 1200 | 2 |
| 1201 – 2400 | 3 |
| > 2400 | 4 |



[12] MUL locking cam

|  | Nº |
|---|--------|
| 33 | 809612 |

|  |  |
|---|---|
| ≤ 1200 | 2 |
| 1201 – 2400 | 3 |
| > 2400 | 4 |

[15] Striker to prevent incorrect operation  1

|  | Nº |
|---|--------|
| Striker to prevent incorrect operation | 822789 |

[16] Parallel Sliding and Tilt&Slide handle – interior handle (200 mm handle length)  1
Sliding door handle – exterior recessed grip (43 mm distance), not sh. 

[17] Striker

|  | Nº |
|---|--------|
| Screw-on | 744579 |

|  |  |
|---|---|
| ≤ 1200 | 2 |
| 1201 – 2400 | 3 |
| > 2400 | 4 |

[18] Buffer  2



|  | Nº |
|---|--------|
| 14 | 635307 |



[20] MUL striker

|  | Nº |
|---|--------|
| Screw-on | 793493 |

|  |  |
|---|---|
| ≤ 1200 | 2 |
| 1201 – 2400 | 3 |
| > 2400 | 4 |

[21] Cover cap for MUL striker, only in combination with MUL striker, screw-on.

|  |  | Nº |
|---|--|--------|
| R01.1 | Natural silver | 819632 |
| R05.3 | Medium bronze | 819631 |
| R06.2 | Jet black | 798979 |
| R07.2 | Traffic white | 808054 |

|  |  |
|---|---|
| ≤ 1200 | 2 |
| 1201 – 2400 | 3 |
| > 2400 | 4 |

[33] Stopper, cannot be used in conjunction with a control unit with SoftOpen and SoftStop on the mullion side.  1



|  | Nº |
|---|--------|
| Stopper | 800196 |

[34] Packer  1

|  | Nº |
|---|--------|
| Packer | 800197 |

Alternatively

[2b] VT espagnolette, lockable (alternative to 2a)  1



|  |  |  |  |  |  |  |  | Nº |
|---|---|---|---|---|---|---|---|--------|
| 35 | 1801 – 2400 | 1890 | 200 | 1000 | 2 | V | Roto Sil | 798034 |
| | 2401 – 2500 | 2290 | 200 | 1000 | 2 | V | Roto Sil | 798055 |

[37] Rubber buffer (alternative to 33)  2

|  | Nº |
|---|--------|
| 14 | 729179 |



Optional

| [35] Brush holder | |
|---|--------|
|  | Nº |
| Brush holder | 809520 |
|  | |
| < 1060 | 2 |
| ≥ 1060 | 3 |

4.2.1.2 Diagram A – RC 2 / RC 2 N





Application range

SRW: 710 – 2000 mm

SRH: 1072 – 2500 mm

S.kg: max. 200 kg

| | | | |
|--------------------------|------------|----------------|--------|
| [1a] Corner drive | With E cam | | 2 |
| [1b] | With V cam | | 2 |
| | | N ^o | |
| 1 | E | | 260275 |
| 1 | V | | 260272 |

| | | | | | | | | | |
|-----------------------------|-------------|------|-----|------|---|---|----------|----------------|---|
| [2a] VT espagnolette | | | | | | | | | 1 |
| | | | | | | | | N ^o | |
| 35 | 600 – 800 | 690 | 200 | 263 | – | – | Roto Sil | 799045 | |
| | 801 – 1000 | 890 | 200 | 413 | – | – | Roto Sil | 798027 | |
| | 1001 – 1200 | 1090 | 200 | 513 | 1 | V | Roto Sil | 798028 | |
| | 1201 – 1600 | 1290 | 200 | 563 | 1 | V | Roto Sil | 798030 | |
| | 1601 – 1800 | 1690 | 200 | 563 | 1 | V | Roto Sil | 798031 | |
| | 1801 – 2400 | 1890 | 200 | 1000 | 2 | V | Roto Sil | 798032 | |
| | 2401 – 2500 | 2290 | 200 | 1000 | 2 | V | Roto Sil | 798033 | |

| | | | | |
|--|---|---|---|----------------|
| Espagnolette extension, (SRH > 1401 mm; not sh.) | | | | |
| | | | | N ^o |
| 200 | Y | – | – | 308267 |
| 400 | Y | – | – | 297858 |

Size-specific combinations:

| | | | | |
|-------------|--------|---|---|----------------|
| | | | | N ^o |
| ≤ 1400 | – | – | – | – |
| 1401 – 1600 | 200 KU | – | – | 308267 |
| 1601 – 2000 | – | – | – | – |
| 2001 – 2200 | 200 KU | – | – | 308267 |
| 2201 – 2400 | 400 KU | – | – | 297858 |
| 2401 – 2500 | 200 KU | – | – | 308267 |

Centre lock (CL)

| | | | | |
|-------------------------------------|---|---|---|----------------|
| [5] CL component, horizontal | | | | |
| | | | | N ^o |
| 200 | – | – | – | 308267 |
| 344 | 1 | V | – | 572665 |
| 480 | – | – | – | 245729 |
| 590 | – | – | – | 603442 |
| 790 | 1 | E | – | 603444 |
| 990 | 1 | E | – | 603447 |
| 1190 | 1 | E | – | 603462 |
| 1440 | 1 | E | – | 603466 |

Size-specific combinations:

| | | | | |
|-------|-----|---|---|----------------|
| | | | | N ^o |
| ≤ 760 | 344 | 1 | V | 572665 |

| | | | | |
|-------------|------|---|---|----------------|
| | | | | N ^o |
| 761 – 860 | 480 | – | – | 245729 |
| 861 – 1060 | 590 | – | – | 603442 |
| 1061 – 1260 | 790 | 1 | E | 603444 |
| 1261 – 1460 | 990 | 1 | E | 603447 |
| 1461 – 1660 | 1190 | 1 | E | 603462 |
| 1661 – 1910 | 1440 | 1 | E | 603466 |
| ≥ 1911 | 1440 | 1 | E | 603466 |
| | 200 | – | – | 308267 |

| | | | | | |
|--|---|---|---|----------------|---|
| [6] Centre lock component 130, horizontal | | | | | 4 |
| | | | | N ^o | |
| 130 | Y | 1 | E | 764350 | |

| | | | | |
|---|---|---|---|----------------|
| [7] CL component, vertical, on the mullion | | | | |
| | | | | N ^o |
| 200 | Y | – | – | 308267 |
| | Y | 1 | E | 450821 |
| 400 | Y | – | – | 297858 |
| 600 | Y | 1 | E | 255282 |
| | N | 1 | E | 255281 |

Size-specific combinations:

| | | | | |
|-------------|--------|---|---|----------------|
| | | | | N ^o |
| 1201 – 1800 | 600 | 1 | E | 255281 |
| 1801 – 2000 | 200 KU | – | – | 308267 |
| | 600 | 1 | E | 255281 |
| 2001 – 2200 | 400 KU | – | – | 297858 |
| | 600 | 1 | E | 255281 |
| 2201 – 2400 | 200 KU | 1 | E | 450821 |
| | 400 KU | – | – | 297858 |
| | 600 | 1 | E | 255281 |
| 2401 – 2500 | 200 KU | – | – | 308267 |
| | 600 KU | 1 | E | 255282 |
| | 200 KU | – | – | 308267 |
| | 600 | 1 | E | 255281 |

| | | |
|------------------------|-------|----------------|
| [9] Roller unit | | |
| | | N ^o |
| 41 | Left | 821686 |
| | Right | 823733 |

| | | |
|--------|--|---|
| | | |
| < 1060 | | 2 |
| ≥ 1060 | | 3 |

[10] Control unit, on the mullion side and in the centre → from page 158 1-2
Alternatively (on the mullion side):
Control unit set with Soft function (incl. activator) → from page 158 1



| | | |
|----|-------|----------------|
| | | N ^o |
| 41 | Left | 821686 |
| | Right | 823730 |



[*] Control unit set with Soft function, on the locking side → *from page 158*  1
Alternatively:
[10] Control unit 

Contents:

| [*] |  | # |
|------|---|---|
| [29] | Activator | 1 |
| [30] | Control unit with Soft function | 1 |



[11] Centre closer 

|  |  | N ^o |
|---|---|----------------|
| 41 | Left | 821687 |
| | Right | 823736 |

|  |  |
|---|---|
| ≤ 1072 | 2 |
| 1073 – 1700 | 3 |
| 1701 – 2100 | 4 |
| > 2100 | 5 |



[12] MUL locking cam 

|  | N ^o |
|--|----------------|
| 33 | 809612 |

|  |  |
|---|---|
| ≤ 1072 | 2 |
| 1073 – 1700 | 3 |
| 1701 – 2100 | 4 |
| > 2100 | 5 |



[15] SEC striker to prevent incorrect operation  1

|  | N ^o |
|---|----------------|
| SEC striker to prevent incorrect operation | 822796 |

[16] Parallel Sliding and Tilt&Slide handle – interior handle, lockable (200 mm handle length)  1
Sliding door handle – exterior recessed grip (43 mm distance), not sh.  1

[17] SEC striker 

|  | N ^o |
|---|----------------|
| Screw-on | 798226 |



|  |  |
|---|---|
| ≤ 1072 | 2 |
| 1073 – 1700 | 3 |
| 1701 – 2100 | 4 |
| > 2100 | 5 |

[18] Buffer  2

|  | N ^o |
|---|----------------|
| 14 | 635307 |

[20] SEC MUL striker 

|  | N ^o |
|---|----------------|
| 31.6 | 833688 |

|  |  |
|---|---|
| ≤ 1072 | 2 |
| 1073 – 1700 | 3 |
| 1701 – 2100 | 4 |
| > 2100 | 5 |



[22] Drilling protection  1

|  | N ^o |
|---|----------------|
| Drilling protection | 770965 |

[24] Pin for anti-pushback function  2

|  | N ^o |
|---|----------------|
| 34 | 822393 |

[25] Centre closer for anti-pushback function  2



|  |  | N ^o |
|---|---|----------------|
| 41 | Left | 821687 |
| | Right | 823736 |

INFO
DIN L: order right components.
DIN R: order left components.

[26] Striker for anti-pushback function  2

|  | N ^o |
|---|----------------|
| Striker for anti-pushback function | 810279 |

[27] Cover cap for SEC MUL striker / striker for anti-pushback function 

|  |  | N ^o |
|---|--|----------------|
| R01.1 | Natural silver | 828482 |
| R05.3 | Medium bronze | 828483 |
| R06.2 | Jet black | 809717 |
| R07.2 | Traffic white | 819351 |

|  |  |
|---|---|
| ≤ 1072 | 2 |
| 1073 – 1700 | 3 |
| 1701 – 2100 | 4 |
| > 2100 | 5 |









[33] Stopper, cannot be used in conjunction with a control unit with SoftOpen and SoftStop on the mullion side.  1



|  | N ^o |
|---|----------------|
| Stopper | 800196 |





| | |
|--|--------|
| [34] Packer  1 | |
|  | Nº |
| Packer | 800197 |





Alternatively

| | |
|--|---|
| [2b] VT espagnolette, lockable (alternative to 2a)  1 | |
|         Nº | |
| 35 | 1801 – 2400 1890 200 1000 2 V Roto Sil 798034 |
| | 2401 – 2500 2290 200 1000 2 V Roto Sil 798055 |

| | |
|---|--------|
| [37] Rubber buffer (alternative to 33)  2 | |
|  | Nº |
| 14 | 729179 |

Optional

| | |
|---|---|
| [35] Brush holder | |
|  | Nº |
| Brush holder | 809520 |
|  |  |
| < 1060 | 2 |
| ≥ 1060 | 3 |

| | |
|--|----------------------------|
| SKG** info clip, not sh.  1 | |
|     Nº | |
| SKG** info clip For clipping onto the gearbox | R07.2 Traffic white 331459 |

4.2.1.3 Diagram C

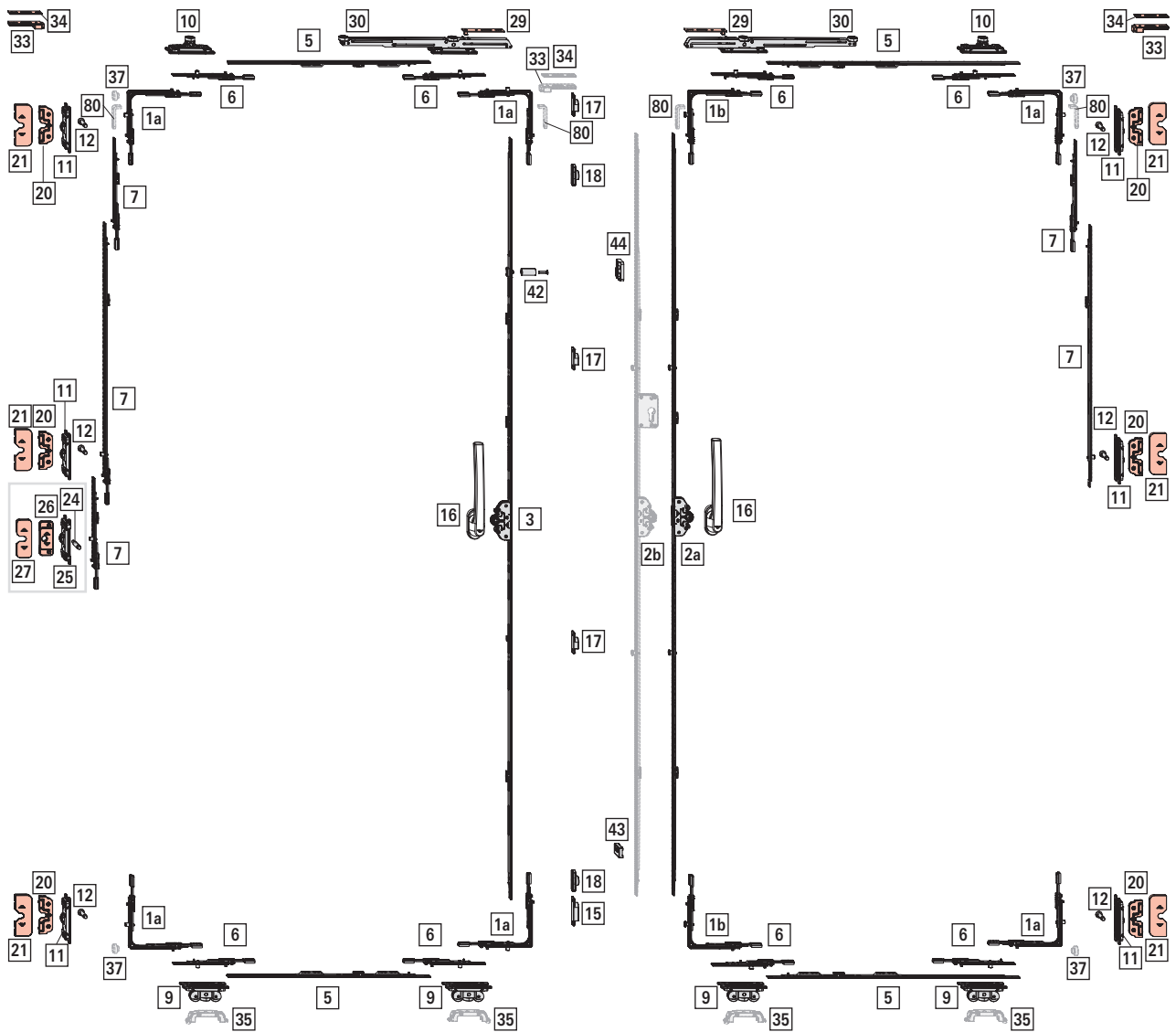



Application range

SRW: 710 – 1500 mm

SRH: 600 – 2500 mm

S.kg: max. 200 kg

| | | | |
|--------------------------|------------|--|---|
| [1a] Corner drive | With E cam | | 6 |
| [1b] | With V cam | | 2 |

| | | Nº |
|---|---|--------|
| 1 | E | 260275 |
| 1 | V | 260272 |

[2a] VT espagnolette

| | | | | | | | | Nº |
|----|-------------|------|-----|------|---|---|----------|--------|
| 35 | 600 – 800 | 690 | 200 | 263 | – | – | Roto Sil | 799045 |
| | 801 – 1000 | 890 | 200 | 413 | – | – | Roto Sil | 798027 |
| | 1001 – 1200 | 1090 | 200 | 513 | 1 | V | Roto Sil | 798028 |
| | 1201 – 1600 | 1290 | 200 | 563 | 1 | V | Roto Sil | 798030 |
| | 1601 – 1800 | 1690 | 200 | 563 | 1 | V | Roto Sil | 798031 |
| | 1801 – 2400 | 1890 | 200 | 1000 | 2 | V | Roto Sil | 798032 |
| | 2401 – 2500 | 2290 | 200 | 1000 | 2 | V | Roto Sil | 798033 |

[3] VT espagnolette, second opening sash

| | | | | | | | | Nº |
|----|-------------|------|-----|------|---|---|----------|--------|
| 35 | 600 – 800 | 690 | 200 | 263 | – | – | Roto Sil | 799045 |
| | 801 – 1000 | 890 | 200 | 413 | – | – | Roto Sil | 798027 |
| | 1001 – 1200 | 1090 | 200 | 513 | – | – | Roto Sil | 809658 |
| | 1201 – 1600 | 1290 | 200 | 563 | – | – | Roto Sil | 809662 |
| | 1601 – 1800 | 1690 | 200 | 563 | – | – | Roto Sil | 809668 |
| | 1801 – 2400 | 1890 | 200 | 1000 | – | – | Roto Sil | 809669 |
| | 2401 – 2500 | 2290 | 200 | 1000 | – | – | Roto Sil | 809653 |

Espagnolette extension, (SRH > 1401 mm; not sh.)

| | | | | Nº |
|-----|---|---|---|--------|
| 200 | Y | – | – | 308267 |
| 400 | Y | – | – | 297858 |

Size-specific combinations:

| | | | | Nº |
|-------------|--------|---|---|--------|
| ≤ 1400 | – | – | – | – |
| 1401 – 1600 | 200 KU | – | – | 308267 |
| 1601 – 2000 | – | – | – | – |
| 2001 – 2200 | 200 KU | – | – | 308267 |
| 2201 – 2400 | 400 KU | – | – | 297858 |
| 2401 – 2500 | 200 KU | – | – | 308267 |

Centre lock (CL)

[5] CL component, horizontal

| | | | Nº |
|-----|---|---|--------|
| 200 | – | – | 308267 |
| 344 | 1 | V | 572665 |

| | | | Nº |
|------|---|---|--------|
| 480 | – | – | 245729 |
| 590 | – | – | 603442 |
| 790 | 1 | E | 603444 |
| 990 | 1 | E | 603447 |
| 1190 | 1 | E | 603462 |
| 1440 | 1 | E | 603466 |

Size-specific combinations:

First or second opening sash

| | | | | Nº |
|-------------|------|---|---|--------|
| ≤ 760 | 344 | 1 | V | 572665 |
| 761 – 860 | 480 | – | – | 245729 |
| 861 – 1060 | 590 | – | – | 603442 |
| 1061 – 1260 | 790 | 1 | E | 603444 |
| 1261 – 1460 | 990 | 1 | E | 603447 |
| 1461 – 1660 | 1190 | 1 | E | 603462 |
| 1661 – 1910 | 1440 | 1 | E | 603466 |
| ≥ 1911 | 1440 | 1 | E | 603466 |
| | 200 | – | – | 308267 |

[6] Centre lock component 130, horizontal and vertical

| | | | | Nº |
|-----|---|---|---|--------|
| 130 | Y | 1 | E | 764350 |

[7] CL component, vertical, on the mullion

| | | | | Nº |
|-----|---|---|---|--------|
| 200 | Y | – | – | 308267 |
| | Y | 1 | E | 450821 |
| 400 | Y | – | – | 297858 |
| 600 | Y | 1 | E | 255282 |
| | N | 1 | E | 255281 |





Size-specific combinations:

First opening sash:

| | | | | Nº |
|-------------|--------|---|---|--------|
| 1201 – 1800 | 600 | 1 | E | 255281 |
| 1801 – 2000 | 200 KU | – | – | 308267 |
| | 600 | 1 | E | 255281 |
| 2001 – 2200 | 400 KU | – | – | 297858 |
| | 600 | 1 | E | 255281 |
| 2201 – 2400 | 200 KU | 1 | E | 450821 |
| | 400 KU | – | – | 297858 |
| | 600 | 1 | E | 255281 |
| 2401 – 2500 | 200 KU | – | – | 308267 |
| | 600 KU | 1 | E | 255282 |
| | 200 KU | – | – | 308267 |
| | 600 | 1 | E | 255281 |

Second opening sash:



| | | | | Nº |
|------------|--------|---|---|--------|
| 600 – 1200 | 200 KU | 1 | E | 450821 |

|  |  |  |  | Nº |
|---|---|---|---|--------|
| 1201 – 1800 | 600 KU | 1 | E | 255282 |
| | 200 KU | 1 | E | 450821 |
| 1801 – 2000 | 200 KU | – | – | 308267 |
| | 600 KU | 1 | E | 255282 |
| 2001 – 2200 | 200 KU | 1 | E | 450821 |
| | 400 KU | – | – | 297858 |
| 2201 – 2400 | 600 KU | 1 | E | 255282 |
| | 200 KU | 1 | E | 450821 |
| 2401 – 2500 | 200 KU | – | – | 308267 |
| | 600 KU | 1 | E | 255282 |
| | 200 KU | – | – | 308267 |
| | 600 KU | 1 | E | 255282 |
| | 200 KU | 1 | E | 450821 |

[9] Roller unit

|  |  | Nº |
|--|--|--------|
| 41 | Left | 821686 |
| | Right | 823733 |



|  | Nº |
|---|----|
| < 1060 | 4 |
| ≥ 1060 | 6 |

[10] Control unit, on the mullion side and in the centre → *from page 158*  2-4
 Alternatively (on the mullion side):
 Control unit set with Soft function (incl. activator) → *from page 158*  1-2

|  |  | Nº |
|---|---|--------|
| 41 | Left | 821685 |
| | Right | 823730 |

[*] Control unit set with Soft function, on the locking side → *from page 158*  2
 Alternatively:
 [10] Control unit 

Contents:

|  |  | # |
|---|---|---|
| [29] | Activator | 1 |
| [30] | Control unit with Soft function | 1 |

[11] Centre closer

|  |  | Nº |
|---|---|--------|
| 41 | Left | 821687 |

|  |  | Nº |
|---|---|--------|
| | Right | 823736 |

|  | Nº |
|---|----|
| ≤ 1200 | 4 |
| 1201 – 2400 | 6 |
| > 2400 | 8 |



[12] MUL locking cam

|  | Nº |
|---|--------|
| 33 | 809612 |

|  | Nº |
|---|----|
| ≤ 1200 | 4 |
| 1201 – 2400 | 6 |
| > 2400 | 8 |

[15] Striker to prevent incorrect operation  1

|  | Nº |
|---|--------|
| Striker to prevent incorrect operation | 822789 |

[16] Parallel Sliding and Tilt&Slide handle – interior handle (200 mm handle length)  2
Sliding door handle – exterior recessed grip (43 mm distance), not sh.  2

[17] Striker

|  | Nº |
|---|--------|
| Screw-on | 744579 |

|  | Nº |
|---|----|
| ≤ 1200 | 2 |
| 1201 – 2400 | 3 |
| > 2400 | 4 |

[18] Buffer  2



|  | Nº |
|---|--------|
| 14 | 635307 |

[20] MUL striker

|  | Nº |
|---|--------|
| Screw-on | 793493 |

|  | Nº |
|---|----|
| ≤ 1200 | 4 |
| 1201 – 2400 | 6 |
| > 2400 | 8 |

[21] Cover cap for MUL striker, only in combination with MUL striker, screw-on.

|  |  | Nº |
|---|--|--------|
| R01.1 | Natural silver | 819632 |
| R05.3 | Medium bronze | 819631 |
| R06.2 | Jet black | 798979 |



| | | |
|-------------|---------------|--------|
| | | Nº |
| R07.2 | Traffic white | 808054 |
| | | |
| ≤ 1200 | | 4 |
| 1201 – 2400 | | 6 |
| > 2400 | | 8 |

[*] Operating sequence control set 1
SRH ≥ 1200 mm, profile-related

| | |
|----|--------|
| | Nº |
| 32 | 833202 |

| | | |
|------------|-------------------------------------|----------|
| [*] | | # |
| [42] | Cam with countersunk screw, M5 x 20 | 1 |
| [43] | Anti-lifting device | 1 |
| [44] | Striker with buffer | 1 |

[24] Pin for anti-pushback function 1

| | |
|----|--------|
| | Nº |
| 34 | 822393 |

[25] Centre closer for anti-pushback function 1

| | | |
|----|-------|--------|
| | | Nº |
| 41 | Left | 821687 |
| | Right | 823736 |



INFO

DIN L: order right components.
DIN R: order left components.

[26] Striker for anti-pushback function 1

| | |
|------------------------------------|--------|
| | Nº |
| Striker for anti-pushback function | 810279 |

[27] Cover cap for striker for anti-pushback function 1

| | | |
|-------|----------------|--------|
| | | Nº |
| R01.1 | Natural silver | 828482 |
| R05.3 | Medium bronze | 828483 |
| R06.2 | Jet black | 809717 |
| R07.2 | Traffic white | 819351 |

[33] Stopper, cannot be used in conjunction with a control unit with SoftOpen / SoftClose together with SoftStop on the mullion side / SoftStop on the locking side. 2

| | |
|---------|--------|
| | Nº |
| Stopper | 800196 |

[34] Packer 2

| | |
|--------|--------|
| | Nº |
| Packer | 800197 |

Alternatively

[2b] VT espagnolette, lockable (alternative to 2a) → from page 146 1

| | | | | | | | | |
|----|-------------|------|-----|------|---|---|----------|--------|
| | | | | | | | | Nº |
| 35 | 1801 – 2400 | 1890 | 200 | 1000 | 2 | V | Roto Sil | 798034 |
| | 2401 – 2500 | 2290 | 200 | 1000 | 2 | V | Roto Sil | 798055 |

[37] Rubber buffer (alternative to 33) 4

| | |
|----|--------|
| | Nº |
| 14 | 729179 |

Optional

[33] Stopper, cannot be used in conjunction with a control unit with SoftOpen and SoftStop on the locking side. 1

| | |
|---------|--------|
| | Nº |
| Stopper | 800196 |

[34] Packer 1

| | |
|--------|--------|
| | Nº |
| Packer | 800197 |

[35] Brush holder

| | |
|--------------|--------|
| | Nº |
| Brush holder | 809520 |

| | |
|--------|---|
| | |
| < 1060 | 4 |
| ≥ 1060 | 6 |

4.2.2 aluplast | smart-slide neo

4.2.2.1 Diagram A, K

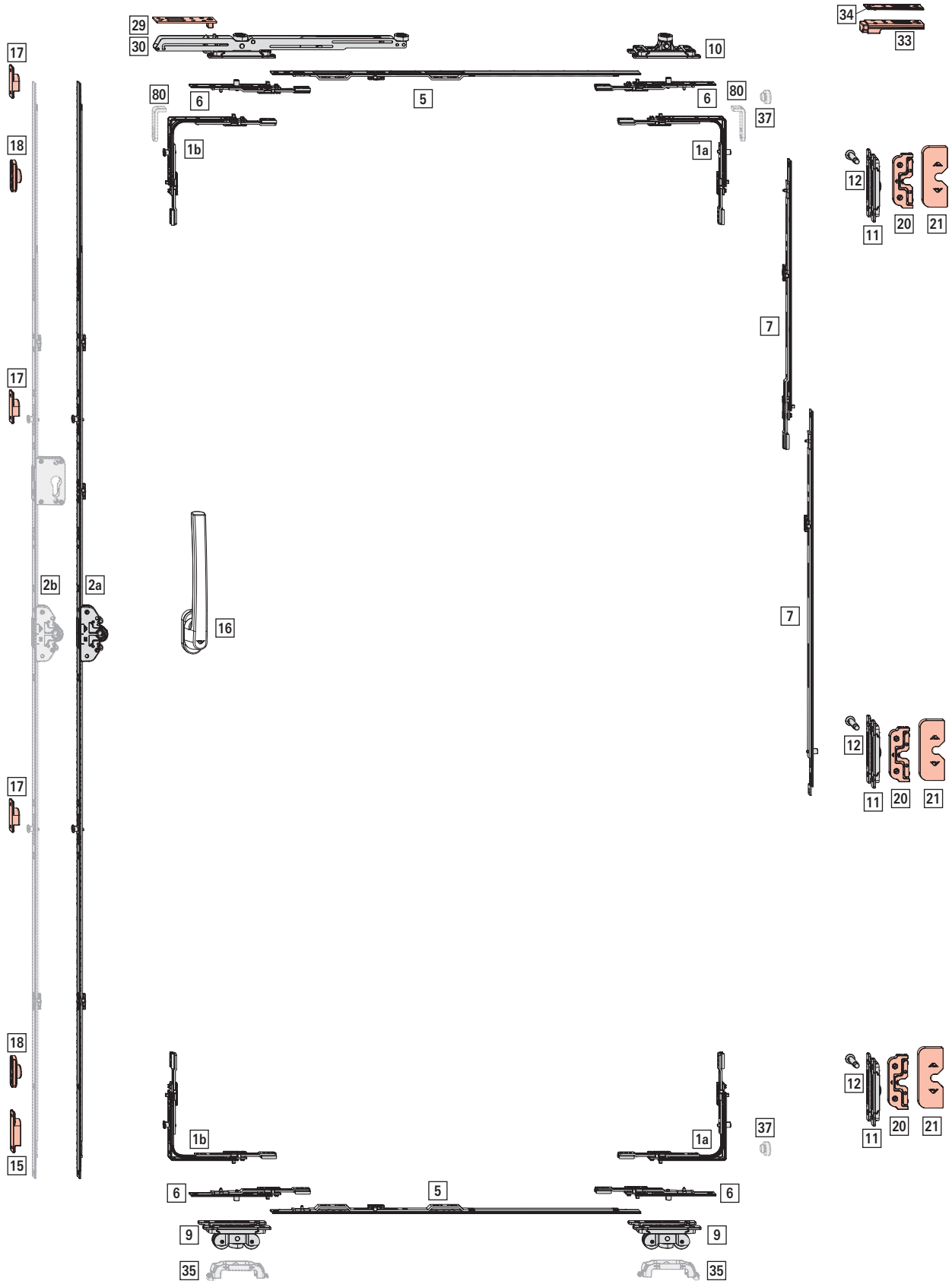



Application range

SRW: 710 – 2000 mm

SRH: 600 – 2500 mm

S.kg: max. 250 kg

| | | |
|-------------------|------------|---|
| [1a] Corner drive | With E cam | 2 |
| [1b] | With V cam | 2 |

| | | Nº |
|---|---|--------|
| 1 | E | 260275 |
| 1 | V | 260272 |

[2a] VT espagnolette 1

| | | | | | | | | | Nº |
|----|-------------|------|-----|------|---|---|----------|--------|----|
| 35 | 600 – 800 | 690 | 200 | 263 | – | – | Roto Sil | 799045 | |
| | 801 – 1000 | 890 | 200 | 413 | – | – | Roto Sil | 798027 | |
| | 1001 – 1200 | 1090 | 200 | 513 | 1 | V | Roto Sil | 798028 | |
| | 1201 – 1600 | 1290 | 200 | 563 | 1 | V | Roto Sil | 798030 | |
| | 1601 – 1800 | 1690 | 200 | 563 | 1 | V | Roto Sil | 798031 | |
| | 1801 – 2400 | 1890 | 200 | 1000 | 2 | V | Roto Sil | 798032 | |
| | 2401 – 2500 | 2290 | 200 | 1000 | 2 | V | Roto Sil | 798033 | |

Espagnolette extension, (SRH > 1401 mm; not sh.)

| | | | | Nº |
|-----|---|---|---|--------|
| 200 | Y | – | – | 308267 |
| 400 | Y | – | – | 297858 |

Size-specific combinations:

| | | | | Nº |
|-------------|--------|---|---|--------|
| ≤ 1400 | – | – | – | – |
| 1401 – 1600 | 200 KU | – | – | 308267 |
| 1601 – 2000 | – | – | – | – |
| 2001 – 2200 | 200 KU | – | – | 308267 |
| 2201 – 2400 | 400 KU | – | – | 297858 |
| 2401 – 2500 | 200 KU | – | – | 308267 |

Centre lock (CL)

[5] CL component, horizontal

| | | | Nº |
|------|---|---|--------|
| 200 | – | – | 308267 |
| 344 | 1 | V | 572665 |
| 480 | – | – | 245729 |
| 590 | – | – | 603442 |
| 790 | 1 | E | 603444 |
| 990 | 1 | E | 603447 |
| 1190 | 1 | E | 603462 |
| 1440 | 1 | E | 603466 |

Size-specific combinations:

| | | | | Nº |
|-------|-----|---|---|--------|
| ≤ 760 | 344 | 1 | V | 572665 |

| | | | | Nº |
|-------------|------|---|---|--------|
| 761 – 860 | 480 | – | – | 245729 |
| 861 – 1060 | 590 | – | – | 603442 |
| 1061 – 1260 | 790 | 1 | E | 603444 |
| 1261 – 1460 | 990 | 1 | E | 603447 |
| 1461 – 1660 | 1190 | 1 | E | 603462 |
| 1661 – 1910 | 1440 | 1 | E | 603466 |
| ≥ 1911 | 1440 | 1 | E | 603466 |
| | 200 | – | – | 308267 |

[6] Centre lock component 130, horizontal 4

| | | | | Nº |
|-----|---|---|---|--------|
| 130 | Y | 1 | E | 764350 |

[7] CL component, vertical, on the mullion

| | | | | Nº |
|-----|---|---|---|--------|
| 200 | Y | – | – | 308267 |
| | Y | 1 | E | 450821 |
| 400 | Y | – | – | 297858 |
| 600 | Y | 1 | E | 255282 |
| | N | 1 | E | 255281 |

Size-specific combinations:

| | | | | Nº |
|-------------|--------|---|---|--------|
| 1201 – 1800 | 600 | 1 | E | 255281 |
| 1801 – 2000 | 200 KU | – | – | 308267 |
| | 600 | 1 | E | 255281 |
| 2001 – 2200 | 400 KU | – | – | 297858 |
| | 600 | 1 | E | 255281 |
| 2201 – 2400 | 200 KU | 1 | E | 450821 |
| | 400 KU | – | – | 297858 |
| | 600 | 1 | E | 255281 |
| 2401 – 2500 | 200 KU | – | – | 308267 |
| | 600 KU | 1 | E | 255282 |
| | 200 KU | – | – | 308267 |
| | 600 | 1 | E | 255281 |

[9] Roller unit

| | | Nº |
|----|-------|--------|
| 41 | Left | 821686 |
| | Right | 823733 |

| < 1060 | 2 |
|--------|---|
| ≥ 1060 | 3 |

[10] Control unit, on the mullion side and in 1-2

the centre

Alternatively (on the mullion side):

Control unit set with Soft function → *from* 1
page 158

Activator for Soft function can be used with an asymmetrical screw fixing → from page 159 

| | | |
|---|---|--------|
|  |  | Nº |
| 41 | Left | 821685 |
| | Right | 823730 |

[*] **Control unit set with Soft function**, on the locking side → from page 158 

Alternatively:

[10] Control unit

Contents:

| [*] |  | # |
|------|---|---|
| [29] | Activator | 1 |
| [30] | Control unit with Soft function | 1 |

[11] Centre closer

| | | |
|---|---|--------|
|  |  | Nº |
| 41 | Left | 821687 |
| | Right | 823736 |

| | |
|--|--|
|  |  |
| ≤ 1200 | 2 |
| 1201 – 2400 | 3 |
| > 2400 | 4 |

[12] MUL locking cam

| | |
|---|---------|
|  | Nº |
| 39.5 | 2009488 |

| | |
|---|---|
|  |  |
| ≤ 1200 | 2 |
| 1201 – 2400 | 3 |
| > 2400 | 4 |

[15] Striker to prevent incorrect operation 

| | |
|---|--------|
|  | Nº |
| Striker to prevent incorrect operation | 822789 |

[16] Parallel Sliding and Tilt&Slide handle – interior handle (200 mm handle length) 

Sliding door handle – exterior recessed grip (43 mm distance), not sh. 

[17] Striker

| | |
|---|--------|
|  | Nº |
| Screw-on | 744579 |

| | |
|---|---|
|  |  |
| ≤ 1200 | 2 |
| 1201 – 2400 | 3 |
| > 2400 | 4 |

[18] Buffer 

| | |
|---|--------|
|  | Nº |
| 14 | 635307 |

[20] MUL striker

| | |
|---|--------|
|  | Nº |
| Screw-on | 793493 |

| | |
|---|---|
|  |  |
| ≤ 1200 | 2 |
| 1201 – 2400 | 3 |
| > 2400 | 4 |

[21] Cover cap for MUL striker, only in combination with MUL striker, screw-on.

| | | |
|---|--|--------|
|  |  | Nº |
| R01.1 | Natural silver | 819632 |
| R05.3 | Medium bronze | 819631 |
| R06.2 | Jet black | 798979 |
| R07.2 | Traffic white | 808054 |

| | |
|--|--|
|  |  |
| ≤ 1200 | 2 |
| 1201 – 2400 | 3 |
| > 2400 | 4 |

[33] Stopper, cannot be used in conjunction with a control unit with SoftOpen and SoftStop on the mullion side. 

| | |
|---|---------|
|  | Nº |
| Stopper | 2027526 |

[34] Packer for an asymmetrical screw fixing 

| | |
|---|---------|
|  | Nº |
| Packer | 2027527 |

Alternatively

[2b] VT espagnolette, lockable (alternative to 2a) 



| | | | | | | | |
|---|---|--|---|---|---|---|-----------------|
|  |  |  |  |  |  |  | Nº |
| 35 | 1801 – 2400 | 1890 | 200 | 1000 | 2 | V | Roto Sil 798034 |
| | 2401 – 2500 | 2290 | 200 | 1000 | 2 | V | Roto Sil 798055 |

[37] Rubber buffer (alternative to 33) 

| | |
|---|--------|
|  | Nº |
| 14 | 729179 |



Optional

| [35] Brush holder | |
|---|--------|
|  | Nº |
| Brush holder | 809520 |
|  | |
| < 1060 | 2 |
| ≥ 1060 | 3 |

4.2.2.2 Diagram A – RC 2 / RC 2 N

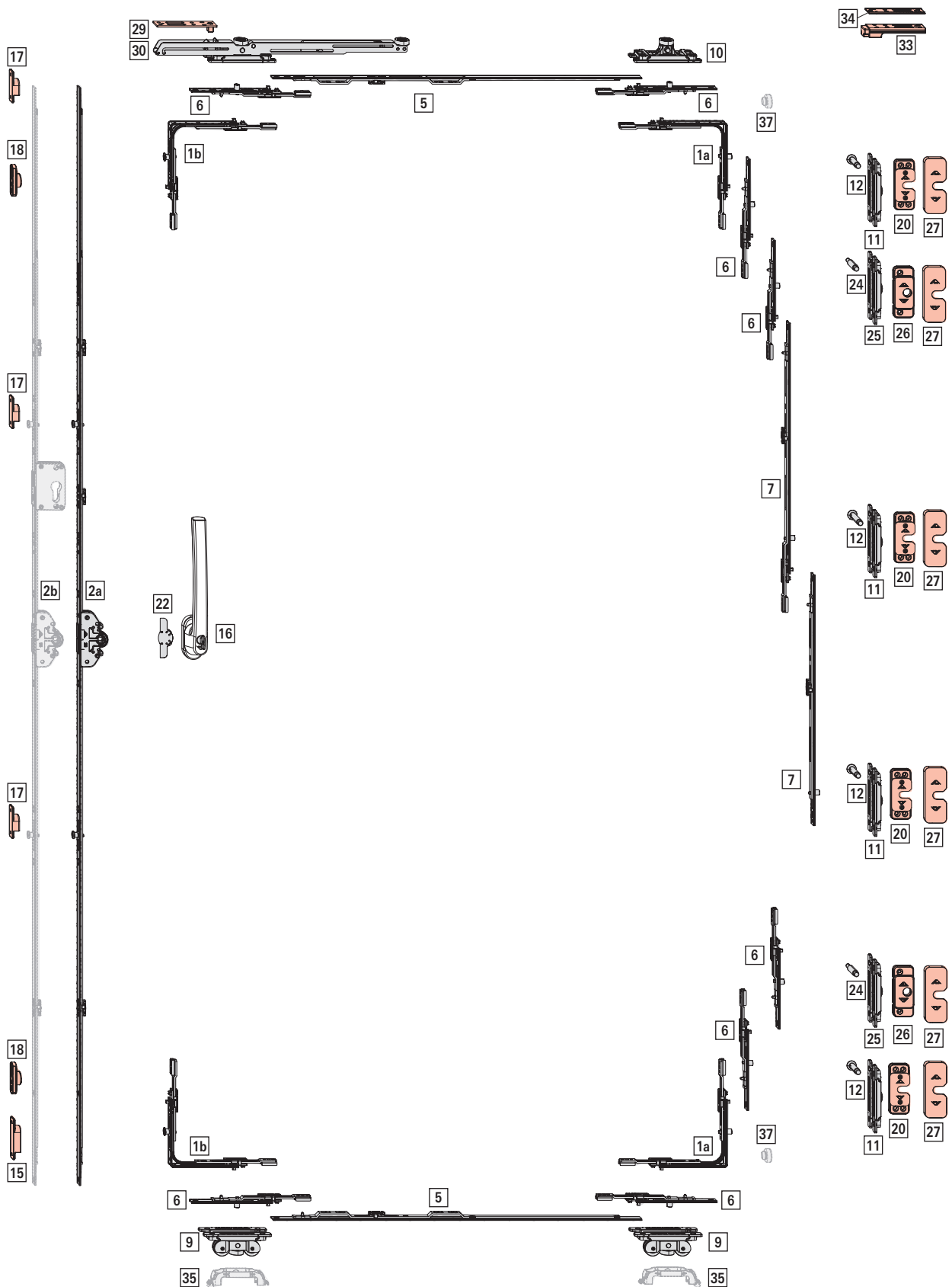



Application range

SRW: 710 – 2000 mm

SRH: 1072 – 2500 mm

S.kg: max. 250 kg

| | | | |
|--------------------------|------------|--|---|
| [1a] Corner drive | With E cam | | 2 |
| [1b] | With V cam | | 2 |

| | | N ^o |
|---|---|----------------|
| 1 | E | 260275 |
| 1 | V | 260272 |

| [2a] VT espagnolette | | | | | | | | | 1 |
|-----------------------------|-------------|------|-----|------|---|---|----------|----------------|---|
| | | | | | | | | N ^o | |
| 35 | 600 – 800 | 690 | 200 | 263 | – | – | Roto Sil | 799045 | |
| | 801 – 1000 | 890 | 200 | 413 | – | – | Roto Sil | 798027 | |
| | 1001 – 1200 | 1090 | 200 | 513 | 1 | V | Roto Sil | 798028 | |
| | 1201 – 1600 | 1290 | 200 | 563 | 1 | V | Roto Sil | 798030 | |
| | 1601 – 1800 | 1690 | 200 | 563 | 1 | V | Roto Sil | 798031 | |
| | 1801 – 2400 | 1890 | 200 | 1000 | 2 | V | Roto Sil | 798032 | |
| | 2401 – 2500 | 2290 | 200 | 1000 | 2 | V | Roto Sil | 798033 | |

| Espagnolette extension, (SRH > 1401 mm; not sh.) | | | | | N ^o |
|--|---|---|---|---|----------------|
| | | | | | N ^o |
| 200 | Y | – | – | – | 308267 |
| 400 | Y | – | – | – | 297858 |

Size-specific combinations:

| | | | | N ^o |
|-------------|--------|---|---|----------------|
| ≤ 1400 | – | – | – | – |
| 1401 – 1600 | 200 KU | – | – | 308267 |
| 1601 – 2000 | – | – | – | – |
| 2001 – 2200 | 200 KU | – | – | 308267 |
| 2201 – 2400 | 400 KU | – | – | 297858 |
| 2401 – 2500 | 200 KU | – | – | 308267 |

Centre lock (CL)

| [5] CL component, horizontal | | | | N ^o |
|-------------------------------------|---|---|---|----------------|
| | | | | N ^o |
| 200 | – | – | – | 308267 |
| 344 | 1 | V | – | 572665 |
| 480 | – | – | – | 245729 |
| 590 | – | – | – | 603442 |
| 790 | 1 | E | – | 603444 |
| 990 | 1 | E | – | 603447 |
| 1190 | 1 | E | – | 603462 |
| 1440 | 1 | E | – | 603466 |

Size-specific combinations:

| | | | | N ^o |
|-------|-----|---|---|----------------|
| ≤ 760 | 344 | 1 | V | 572665 |

| | | | | N ^o |
|-------------|------|---|---|----------------|
| 761 – 860 | 480 | – | – | 245729 |
| 861 – 1060 | 590 | – | – | 603442 |
| 1061 – 1260 | 790 | 1 | E | 603444 |
| 1261 – 1460 | 990 | 1 | E | 603447 |
| 1461 – 1660 | 1190 | 1 | E | 603462 |
| 1661 – 1910 | 1440 | 1 | E | 603466 |
| ≥ 1911 | 1440 | 1 | E | 603466 |
| | 200 | – | – | 308267 |

| [6] Centre lock component 130, horizontal | | | | | | 4 |
|--|---|---|---|----------------|--|---|
| | | | | N ^o | | |
| 130 | Y | 1 | E | 764350 | | |

| [7] CL component, vertical, on the mullion | | | | | N ^o |
|---|---|---|---|----------------|----------------|
| | | | | N ^o | |
| 200 | Y | – | – | 308267 | |
| | Y | 1 | E | 450821 | |
| 400 | Y | – | – | 297858 | |
| 600 | Y | 1 | E | 255282 | |
| | N | 1 | E | 255281 | |

Size-specific combinations:

| | | | | N ^o |
|-------------|--------|---|---|----------------|
| 1201 – 1800 | 600 | 1 | E | 255281 |
| 1801 – 2000 | 200 KU | – | – | 308267 |
| | 600 | 1 | E | 255281 |
| 2001 – 2200 | 400 KU | – | – | 297858 |
| | 600 | 1 | E | 255281 |
| 2201 – 2400 | 200 KU | 1 | E | 450821 |
| | 400 KU | – | – | 297858 |
| | 600 | 1 | E | 255281 |
| 2401 – 2500 | 200 KU | – | – | 308267 |
| | 600 KU | 1 | E | 255282 |
| | 200 KU | – | – | 308267 |
| | 600 | 1 | E | 255281 |

| [9] Roller unit | | | N ^o |
|------------------------|-------|--|----------------|
| | | | N ^o |
| 41 | Left | | 821686 |
| | Right | | 823733 |

| | | N ^o |
|--------|--|----------------|
| < 1060 | | 2 |
| ≥ 1060 | | 3 |

[10] Control unit, on the mullion side and in the centre 1-2
Alternatively (on the mullion side):
Control unit set with Soft function → *from* 1
page 158

Activator for Soft function can be used with an asymmetrical screw fixing → from page 159 

| | | |
|---|---|--------|
|  |  | Nº |
| 41 | Left | 821685 |
| | Right | 823730 |

[*] **Control unit set with Soft function**, on the locking side → from page 158 
Alternatively:
[10] Control unit 

Contents:

| [*] |  | # |
|------|---|---|
| [29] | Activator | 1 |
| [30] | Control unit with Soft function | 1 |

[11] Centre closer

| | | |
|---|---|--------|
|  |  | Nº |
| 41 | Left | 821687 |
| | Right | 823736 |

| | |
|--|--|
|  |  |
| ≤ 1072 | 2 |
| 1073 – 1700 | 3 |
| 1701 – 2100 | 4 |
| > 2100 | 5 |



[12] MUL locking cam

| | |
|---|---------|
|  | Nº |
| 39.5 | 2009488 |

| | |
|---|---|
|  |  |
| ≤ 1072 | 2 |
| 1073 – 1700 | 3 |
| 1701 – 2100 | 4 |
| > 2100 | 5 |

[15] SEC striker to prevent incorrect operation 



| | |
|---|--------|
|  | Nº |
| SEC striker to prevent incorrect operation | 822796 |

[16] Parallel Sliding and Tilt&Slide handle – interior handle, lockable (200 mm handle length) 
Sliding door handle – exterior recessed grip (43 mm distance), not sh. 

[17] SEC striker

| | |
|---|--------|
|  | Nº |
| Screw-on | 798226 |

| | |
|---|---|
|  |  |
| ≤ 1072 | 2 |

| | |
|---|---|
|  |  |
| 1073 – 1700 | 3 |
| 1701 – 2100 | 4 |
| > 2100 | 5 |

[18] Buffer 

| | |
|---|--------|
|  | Nº |
| 14 | 635307 |

[20] SEC MUL striker

| | |
|---|--------|
|  | Nº |
| 31.6 | 833688 |

| | |
|---|---|
|  |  |
| ≤ 1072 | 2 |
| 1073 – 1700 | 3 |
| 1701 – 2100 | 4 |
| > 2100 | 5 |

[22] Drilling protection 

| | |
|---|--------|
|  | Nº |
| Drilling protection | 770965 |

[24] Pin for anti-pushback function 

| | |
|---|---------|
|  | Nº |
| 39.5 | 2009506 |

[25] Centre closer for anti-pushback function 



| | | |
|---|---|--------|
|  |  | Nº |
| 41 | Left | 821687 |
| | Right | 823736 |

 **INFO**
DIN L: order right components.
DIN R: order left components.

[26] Striker for anti-pushback function 

| | |
|---|--------|
|  | Nº |
| Striker for anti-pushback function | 810279 |

[27] Cover cap for SEC MUL striker / striker for anti-pushback function

| | | |
|---|--|--------|
|  |  | Nº |
| R01.1 | Natural silver | 828482 |
| R05.3 | Medium bronze | 828483 |
| R06.2 | Jet black | 809717 |
| R07.2 | Traffic white | 819351 |

| | |
|---|---|
|  |  |
| ≤ 1072 | 2 |
| 1073 – 1700 | 3 |
| 1701 – 2100 | 4 |
| > 2100 | 5 |



[33] Stopper for an asymmetrical screw fixing,  1
cannot be used in conjunction with a control unit with SoftOpen and SoftStop on the mullion side.



Nº

Stopper 2027526

[34] Packer for an asymmetrical screw fixing  1



Nº

Packer 2027527

Alternatively

[2b] VT espagnolette, lockable (alternative to 2a)  1



Nº

| | | | | | | | | |
|----|-------------|------|-----|------|---|---|----------|--------|
| 35 | 1801 – 2400 | 1890 | 200 | 1000 | 2 | V | Roto Sil | 798034 |
| | 2401 – 2500 | 2290 | 200 | 1000 | 2 | V | Roto Sil | 798055 |

[37] Rubber buffer (alternative to 33)  2



Nº

14 729179

Optional

[35] Brush holder



Nº

Brush holder 809520



< 1060 2

≥ 1060 3

SKG info clip**, not sh.  1



Nº

| | | | | |
|-----------------|-------------------------------|-------|---------------|--------|
| SKG** info clip | For clipping onto the gearbox | R07.2 | Traffic white | 331459 |
|-----------------|-------------------------------|-------|---------------|--------|

4.2.2.3 Diagram C

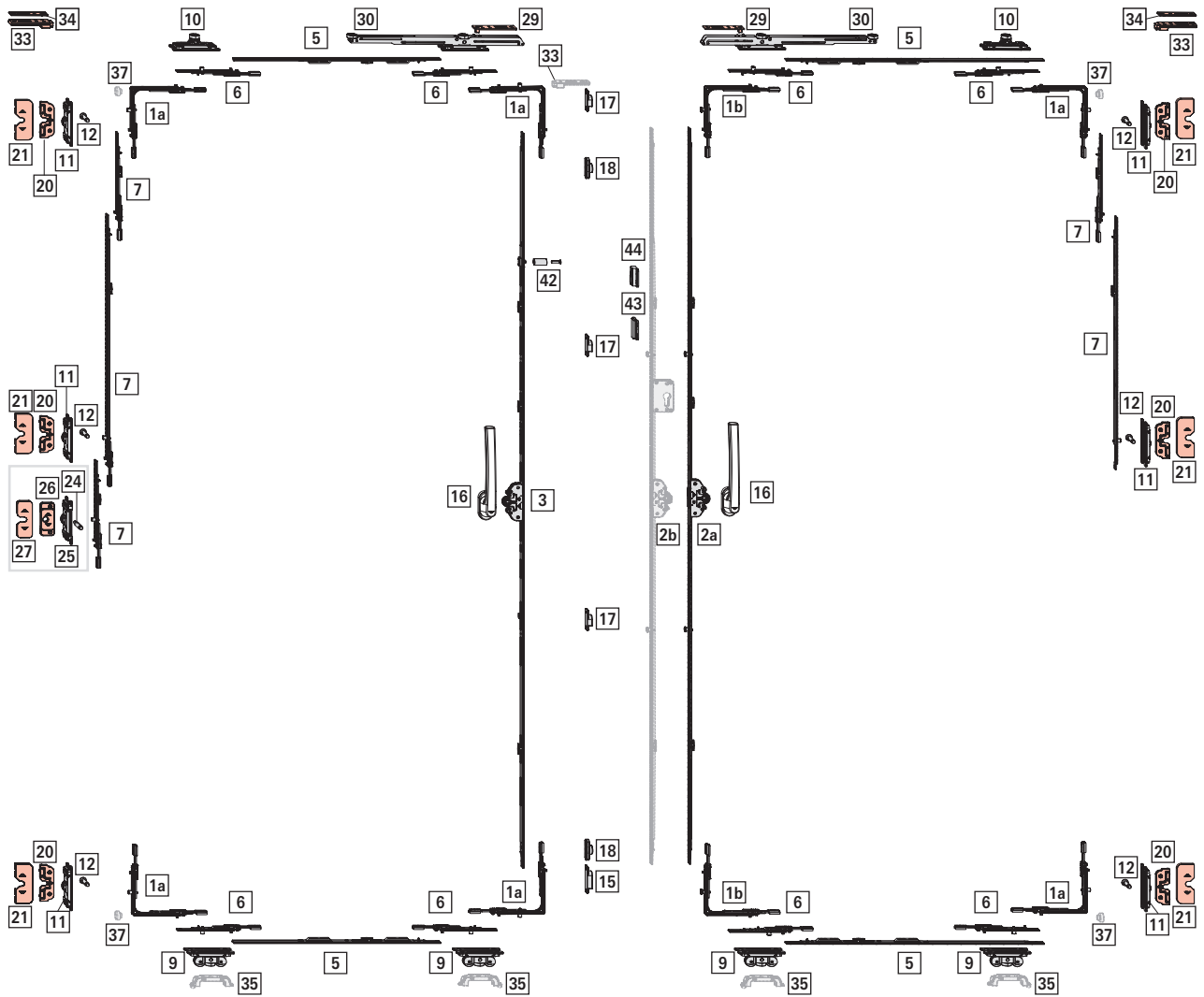



Application range

SRW: 710 – 1500 mm

SRH: 600 – 2500 mm

S.kg: max. 250 kg

| | | | |
|-------------------|------------|--|---|
| [1a] Corner drive | With E cam | | 6 |
| [1b] | With V cam | | 2 |

| | | Nº |
|---|---|--------|
| 1 | E | 260275 |
| 1 | V | 260272 |

[2a] VT espagnolette

| | | | | | | | | Nº |
|----|-------------|------|-----|------|---|---|----------|--------|
| 35 | 600 – 800 | 690 | 200 | 263 | – | – | Roto Sil | 799045 |
| | 801 – 1000 | 890 | 200 | 413 | – | – | Roto Sil | 798027 |
| | 1001 – 1200 | 1090 | 200 | 513 | 1 | V | Roto Sil | 798028 |
| | 1201 – 1600 | 1290 | 200 | 563 | 1 | V | Roto Sil | 798030 |
| | 1601 – 1800 | 1690 | 200 | 563 | 1 | V | Roto Sil | 798031 |
| | 1801 – 2400 | 1890 | 200 | 1000 | 2 | V | Roto Sil | 798032 |
| | 2401 – 2500 | 2290 | 200 | 1000 | 2 | V | Roto Sil | 798033 |

[3] VT espagnolette, second opening sash

| | | | | | | | | Nº |
|----|-------------|------|-----|------|---|---|----------|--------|
| 35 | 600 – 800 | 690 | 200 | 263 | – | – | Roto Sil | 799045 |
| | 801 – 1000 | 890 | 200 | 413 | – | – | Roto Sil | 798027 |
| | 1001 – 1200 | 1090 | 200 | 513 | – | – | Roto Sil | 809658 |
| | 1201 – 1600 | 1290 | 200 | 563 | – | – | Roto Sil | 809662 |
| | 1601 – 1800 | 1690 | 200 | 563 | – | – | Roto Sil | 809668 |
| | 1801 – 2400 | 1890 | 200 | 1000 | – | – | Roto Sil | 809669 |
| | 2401 – 2500 | 2290 | 200 | 1000 | – | – | Roto Sil | 809653 |

Espagnolette extension, (SRH > 1401 mm; not sh.)

| | | | | Nº |
|-----|---|---|---|--------|
| 200 | Y | – | – | 308267 |
| 400 | Y | – | – | 297858 |

Size-specific combinations:

| | | | | Nº |
|-------------|--------|---|---|--------|
| ≤ 1400 | – | – | – | – |
| 1401 – 1600 | 200 KU | – | – | 308267 |
| 1601 – 2000 | – | – | – | – |
| 2001 – 2200 | 200 KU | – | – | 308267 |
| 2201 – 2400 | 400 KU | – | – | 297858 |
| 2401 – 2500 | 200 KU | – | – | 308267 |

Centre lock (CL)

[5] CL component, horizontal

| | | | Nº |
|-----|---|---|--------|
| 200 | – | – | 308267 |
| 344 | 1 | V | 572665 |

| | | | Nº |
|------|---|---|--------|
| 480 | – | – | 245729 |
| 590 | – | – | 603442 |
| 790 | 1 | E | 603444 |
| 990 | 1 | E | 603447 |
| 1190 | 1 | E | 603462 |
| 1440 | 1 | E | 603466 |

Size-specific combinations:

First or second opening sash

| | | | | Nº |
|-------------|------|---|---|--------|
| ≤ 760 | 344 | 1 | V | 572665 |
| 761 – 860 | 480 | – | – | 245729 |
| 861 – 1060 | 590 | – | – | 603442 |
| 1061 – 1260 | 790 | 1 | E | 603444 |
| 1261 – 1460 | 990 | 1 | E | 603447 |
| 1461 – 1660 | 1190 | 1 | E | 603462 |
| 1661 – 1910 | 1440 | 1 | E | 603466 |
| ≥ 1911 | 1440 | 1 | E | 603466 |
| | 200 | – | – | 308267 |

[6] Centre lock component 130, horizontal and vertical

| | | | | Nº |
|-----|---|---|---|--------|
| 130 | Y | 1 | E | 764350 |

[7] CL component, vertical, on the mullion

| | | | | Nº |
|-----|---|---|---|--------|
| 200 | Y | – | – | 308267 |
| | Y | 1 | E | 450821 |
| 400 | Y | – | – | 297858 |
| 600 | Y | 1 | E | 255282 |
| | N | 1 | E | 255281 |





Size-specific combinations:

First opening sash:

| | | | | Nº |
|-------------|--------|---|---|--------|
| 1201 – 1800 | 600 | 1 | E | 255281 |
| 1801 – 2000 | 200 KU | – | – | 308267 |
| | 600 | 1 | E | 255281 |
| 2001 – 2200 | 400 KU | – | – | 297858 |
| | 600 | 1 | E | 255281 |
| 2201 – 2400 | 200 KU | 1 | E | 450821 |
| | 400 KU | – | – | 297858 |
| | 600 | 1 | E | 255281 |
| 2401 – 2500 | 200 KU | – | – | 308267 |
| | 600 KU | 1 | E | 255282 |
| | 200 KU | – | – | 308267 |
| | 600 | 1 | E | 255281 |

Second opening sash:



| | | | | Nº |
|------------|--------|---|---|--------|
| 600 – 1200 | 200 KU | 1 | E | 450821 |

|  |  |  |  | Nº |
|---|---|---|---|--------|
| 1201 – 1800 | 600 KU | 1 | E | 255282 |
| | 200 KU | 1 | E | 450821 |
| 1801 – 2000 | 200 KU | – | – | 308267 |
| | 600 KU | 1 | E | 255282 |
| 2001 – 2200 | 200 KU | 1 | E | 450821 |
| | 400 KU | – | – | 297858 |
| 2201 – 2400 | 600 KU | 1 | E | 255282 |
| | 200 KU | 1 | E | 450821 |
| 2401 – 2500 | 200 KU | – | – | 308267 |
| | 600 KU | 1 | E | 255282 |
| | 200 KU | – | – | 308267 |
| | 600 KU | 1 | E | 255282 |
| | 200 KU | 1 | E | 450821 |

[9] Roller unit

|  |  | Nº |
|--|--|--------|
| 41 | Left | 821686 |
| | Right | 823733 |

|  | Nº |
|---|----|
| < 1060 | 4 |
| ≥ 1060 | 6 |



[10] Control unit, on the mullion side and in the centre  2-4
Alternatively (on the mullion side):
Control unit set with Soft function → *from page 158*  2
Activator for Soft function can be used with an asymmetrical screw fixing → *from page 159*  2

|  |  | Nº |
|---|---|--------|
| 41 | Left | 821685 |
| | Right | 823730 |

[*] Control unit set with Soft function, on the locking side → *from page 158*  2
Alternatively:

[10] Control unit

Contents:

|  |  | # |
|---|---|---|
| [29] | Activator | 1 |
| [30] | Control unit with Soft function | 1 |

[11] Centre closer

|  |  | Nº |
|---|---|--------|
| 41 | Left | 821687 |

|  |  | Nº |
|---|---|--------|
| | Right | 823736 |

|  | Nº |
|---|----|
| ≤ 1200 | 4 |
| 1201 – 2400 | 6 |
| > 2400 | 8 |



[12] MUL locking cam

|  | Nº |
|---|--------|
| 33 | 809612 |

|  | Nº |
|---|----|
| ≤ 1200 | 4 |
| 1201 – 2400 | 6 |
| > 2400 | 8 |

[15] Striker to prevent incorrect operation  1

|  | Nº |
|---|--------|
| Striker to prevent incorrect operation | 822789 |

[16] Parallel Sliding and Tilt&Slide handle – interior handle (200 mm handle length)  2
Sliding door handle – exterior recessed grip (43 mm distance), not sh.  2

[17] Striker

|  | Nº |
|---|--------|
| Screw-on | 744579 |

|  | Nº |
|---|----|
| ≤ 1200 | 2 |
| 1201 – 2400 | 3 |
| > 2400 | 4 |

[18] Buffer  2



|  | Nº |
|---|--------|
| 14 | 635307 |

[20] MUL striker





|  | Nº |
|---|--------|
| Screw-on | 793493 |

|  | Nº |
|---|----|
| ≤ 1200 | 4 |
| 1201 – 2400 | 6 |
| > 2400 | 8 |

[21] Cover cap for MUL striker, only in combination with MUL striker, screw-on.

|  |  | Nº |
|---|--|--------|
| R01.1 | Natural silver | 819632 |
| R05.3 | Medium bronze | 819631 |
| R06.2 | Jet black | 798979 |



| | | |
|---|---|----------------|
|  |  | N ^o |
| R07.2 | Traffic white | 808054 |
|  |  | |
| ≤ 1200 | 4 | |
| 1201 – 2400 | 6 | |
| > 2400 | 8 | |

[*] Operating sequence control set  1
SRH ≥ 1200 mm, profile-related

| | |
|---|----------------|
|  | N ^o |
| 28 | 2027961 |

| | |
|--|---|
| [*]  | # |
| [42] Cam with countersunk screw, M5 x 20 | 1 |
| [43] Anti-lifting device | 1 |
| [44] Striker with buffer | 1 |

[24] Pin for anti-pushback function  1

| | |
|---|----------------|
|  | N ^o |
| 39.5 | 2009506 |

[25] Centre closer for anti-pushback function  1

| | | |
|---|---|----------------|
|  |  | N ^o |
| 41 | Left | 821687 |
| | Right | 823736 |





INFO

DIN L: order right components.
DIN R: order left components.

[26] Striker for anti-pushback function  1

| | |
|---|----------------|
|  | N ^o |
| Striker for anti-pushback function | 810279 |

[27] Cover cap for striker for anti-pushback function  1

| | | |
|---|---|----------------|
|  |  | N ^o |
| R01.1 | Natural silver | 828482 |
| R05.3 | Medium bronze | 828483 |
| R06.2 | Jet black | 809717 |
| R07.2 | Traffic white | 819351 |

[33] Stopper for an asymmetrical screw fixing,  2
cannot be used in conjunction with a control unit with SoftOpen / SoftClose together with SoftStop on the mullion side / SoftStop on the locking side.









| | |
|---|----------------|
|  | N ^o |
| Stopper | 2027526 |

[34] Packer for an asymmetrical screw fixing  2

| | |
|---|----------------|
|  | N ^o |
| Packer | 2027527 |

Alternatively

[2b] VT espagnolette, lockable (alternative to 2a) → from page 146  1



| | | | | | | | | |
|---|---|--|---|---|---|---|---|----------------|
|  |  |  |  |  |  |  |  | N ^o |
| 35 | 1801 – 2400 | 1890 | 200 | 1000 | 2 | V | Roto Sil | 798034 |
| | 2401 – 2500 | 2290 | 200 | 1000 | 2 | V | Roto Sil | 798055 |

[37] Rubber buffer (alternative to 33)  4

| | |
|---|----------------|
|  | N ^o |
| 14 | 729179 |

Optional

[35] Brush holder

| | |
|---|---|
|  | N ^o |
| Brush holder | 809520 |
|  |  |
| < 1060 | 4 |
| ≥ 1060 | 6 |

4.2.3 GEALAN | SMOOVIO

4.2.3.1 Diagram A





Application range

SRW: 710 – 2000 mm

SRH: 600 – 2500 mm

S.kg: max. 200 kg

| | | | |
|--------------------------|------------|----------------|--------|
| [1a] Corner drive | With E cam | | 2 |
| [1b] | With V cam | | 2 |
| | | N ^o | |
| 1 | E | | 260275 |
| 1 | V | | 260272 |

| | | | | | | | | | |
|-----------------------------|-------------|------|-----|------|---|---|----------|----------------|---|
| [2a] VT espagnolette | | | | | | | | | 1 |
| | | | | | | | | N ^o | |
| 35 | 600 – 800 | 690 | 200 | 263 | – | – | Roto Sil | 799045 | |
| | 801 – 1000 | 890 | 200 | 413 | – | – | Roto Sil | 798027 | |
| | 1001 – 1200 | 1090 | 200 | 513 | 1 | V | Roto Sil | 798028 | |
| | 1201 – 1600 | 1290 | 200 | 563 | 1 | V | Roto Sil | 798030 | |
| | 1601 – 1800 | 1690 | 200 | 563 | 1 | V | Roto Sil | 798031 | |
| | 1801 – 2400 | 1890 | 200 | 1000 | 2 | V | Roto Sil | 798032 | |
| | 2401 – 2500 | 2290 | 200 | 1000 | 2 | V | Roto Sil | 798033 | |

| | | | | |
|--|---|---|---|----------------|
| Espagnolette extension, (SRH > 1401 mm; not sh.) | | | | |
| | | | | N ^o |
| 200 | Y | – | – | 308267 |
| 400 | Y | – | – | 297858 |

Size-specific combinations:

| | | | | |
|-------------|--------|---|---|----------------|
| | | | | N ^o |
| ≤ 1400 | – | – | – | – |
| 1401 – 1600 | 200 KU | – | – | 308267 |
| 1601 – 2000 | – | – | – | – |
| 2001 – 2200 | 200 KU | – | – | 308267 |
| 2201 – 2400 | 400 KU | – | – | 297858 |
| 2401 – 2500 | 200 KU | – | – | 308267 |

Centre lock (CL)

| | | | | | |
|-------------------------------------|---|---|---|----------------|--------|
| [5] CL component, horizontal | | | | | |
| | | | | N ^o | |
| 200 | – | – | – | | 308267 |
| 344 | 1 | – | V | | 572665 |
| 480 | – | – | – | | 245729 |
| 590 | – | – | – | | 603442 |
| 790 | 1 | – | E | | 603444 |
| 990 | 1 | – | E | | 603447 |
| 1190 | 1 | – | E | | 603462 |
| 1440 | 1 | – | E | | 603466 |

Size-specific combinations:

| | | | | |
|-------|-----|---|---|----------------|
| | | | | N ^o |
| ≤ 760 | 344 | 1 | V | 572665 |

| | | | | |
|-------------|------|---|---|----------------|
| | | | | N ^o |
| 761 – 860 | 480 | – | – | 245729 |
| 861 – 1060 | 590 | – | – | 603442 |
| 1061 – 1260 | 790 | 1 | E | 603444 |
| 1261 – 1460 | 990 | 1 | E | 603447 |
| 1461 – 1660 | 1190 | 1 | E | 603462 |
| 1661 – 1910 | 1440 | 1 | E | 603466 |
| ≥ 1911 | 1440 | 1 | E | 603466 |
| | 200 | – | – | 308267 |

| | | | | | |
|--|---|---|---|----------------|--------|
| [6] Centre lock component 130, horizontal | | | | | 4 |
| | | | | N ^o | |
| 130 | Y | 1 | E | | 764350 |

| | | | | |
|---|---|---|---|----------------|
| [7] CL component, vertical, on the mullion | | | | |
| | | | | N ^o |
| 200 | Y | – | – | 308267 |
| | Y | 1 | E | 450821 |
| 400 | Y | – | – | 297858 |
| 600 | Y | 1 | E | 255282 |
| | N | 1 | E | 255281 |

Size-specific combinations:

| | | | | |
|-------------|--------|---|---|----------------|
| | | | | N ^o |
| 1201 – 1800 | 600 | 1 | E | 255281 |
| 1801 – 2000 | 200 KU | – | – | 308267 |
| | 600 | 1 | E | 255281 |
| 2001 – 2200 | 400 KU | – | – | 297858 |
| | 600 | 1 | E | 255281 |
| 2201 – 2400 | 200 KU | 1 | E | 450821 |
| | 400 KU | – | – | 297858 |
| | 600 | 1 | E | 255281 |
| 2401 – 2500 | 200 KU | – | – | 308267 |
| | 600 KU | 1 | E | 255282 |
| | 200 KU | – | – | 308267 |
| | 600 | 1 | E | 255281 |

| | | |
|------------------------|-------|----------------|
| [9] Roller unit | | |
| | | N ^o |
| 41 | Left | 821686 |
| | Right | 823733 |

| | | |
|--------|--|---|
| | | |
| < 1060 | | 2 |
| ≥ 1060 | | 3 |

[10] Control unit, on the mullion side and in the centre → from page 158 1-2
Alternatively (on the mullion side):
Control unit set with Soft function (incl. activator) → from page 158 1

| | | |
|----|-------|----------------|
| | | N ^o |
| 41 | Left | 821685 |
| | Right | 823730 |

[*] Control unit set with Soft function, on the locking side → *from page 158*  1
Alternatively:
[10] Control unit 

Contents:

| [*] |  | # |
|------|---|---|
| [29] | Activator | 1 |
| [30] | Control unit with Soft function | 1 |

[11] Centre closer

|  |  | Nº |
|---|---|--------|
| 41 | Left | 821687 |
| | Right | 823736 |

|  |  |
|---|---|
| ≤ 1200 | 2 |
| 1201 – 2400 | 3 |
| > 2400 | 4 |



[12] MUL locking cam

|  | Nº |
|---|--------|
| 38.4 | 809614 |

|  |  |
|---|---|
| ≤ 1200 | 2 |
| 1201 – 2400 | 3 |
| > 2400 | 4 |



[15] Striker to prevent incorrect operation  1

|  | Nº |
|---|--------|
| Striker to prevent incorrect operation | 822789 |

[16] Parallel Sliding and Tilt&Slide handle – interior handle (200 mm handle length)  1
Sliding door handle – exterior recessed grip (43 mm distance), not sh.  1

[17] Striker

|  | Nº |
|---|--------|
| Screw-on | 744579 |

|  |  |
|---|---|
| ≤ 1200 | 2 |
| 1201 – 2400 | 3 |
| > 2400 | 4 |

[18] Buffer  2



|  | Nº |
|---|--------|
| 14 | 635307 |

[20] MUL striker

|  | Nº |
|---|--------|
| Screw-on | 793493 |

|  |  |
|---|---|
| ≤ 1200 | 2 |
| 1201 – 2400 | 3 |
| > 2400 | 4 |

[21] Cover cap for MUL striker, only in combination with MUL striker, screw-on.

|  |  | Nº |
|---|--|--------|
| R01.1 | Natural silver | 819632 |
| R05.3 | Medium bronze | 819631 |
| R06.2 | Jet black | 798979 |
| R07.2 | Traffic white | 808054 |





|  |  |
|---|---|
| ≤ 1200 | 2 |
| 1201 – 2400 | 3 |
| > 2400 | 4 |

[33] Stopper, cannot be used in conjunction with a control unit with SoftOpen and SoftStop on the mullion side.  1

|  | Nº |
|---|--------|
| Stopper | 800196 |

Alternatively

[2b] VT espagnolette, lockable (alternative to 2a)  1

|  |  |  |  |  |  |  |  | Nº |
|---|---|---|---|---|---|---|---|--------|
| 35 | 1801 – 2400 | 1890 | 200 | 1000 | 2 | V | Roto Sil | 798034 |
| | 2401 – 2500 | 2290 | 200 | 1000 | 2 | V | Roto Sil | 798055 |

[37] Rubber buffer (alternative to 33)  2

|  | Nº |
|---|--------|
| 14 | 729179 |

Optional

[35] Brush holder

|  | Nº |
|---|--------|
| Brush holder | 809520 |

|  |  |
|---|---|
| < 1060 | 2 |
| ≥ 1060 | 3 |



[80] **Tilt protection device**; for application ranges SRH:SRW = > 2:1 up to max. 3:1; can only be used without control unit with Soft function.  2



Nº

Tilt protection device

897049

4.2.3.2 Diagram A – RC 2 / RC 2 N





Application range

SRW: 710 – 2000 mm

SRH: 1072 – 2500 mm

S.kg: max. 200 kg

| | | | |
|--------------------------|------------|-----------|---|
| [1a] Corner drive | With E cam | | 2 |
| [1b] | With V cam | | 2 |
| | | Nº | |
| 1 | E | 260275 | |
| 1 | V | 260272 | |

| | | | | | | | | | |
|-----------------------------|-------------|------|-----|------|---|---|----------|-----------|---|
| [2a] VT espagnolette | | | | | | | | | 1 |
| | | | | | | | | Nº | |
| 35 | 600 – 800 | 690 | 200 | 263 | – | – | Roto Sil | 799045 | |
| | 801 – 1000 | 890 | 200 | 413 | – | – | Roto Sil | 798027 | |
| | 1001 – 1200 | 1090 | 200 | 513 | 1 | V | Roto Sil | 798028 | |
| | 1201 – 1600 | 1290 | 200 | 563 | 1 | V | Roto Sil | 798030 | |
| | 1601 – 1800 | 1690 | 200 | 563 | 1 | V | Roto Sil | 798031 | |
| | 1801 – 2400 | 1890 | 200 | 1000 | 2 | V | Roto Sil | 798032 | |
| | 2401 – 2500 | 2290 | 200 | 1000 | 2 | V | Roto Sil | 798033 | |

Espagnolette extension, (SRH > 1401 mm; not sh.)

| | | | | |
|-----|---|---|---|-----------|
| | | | | Nº |
| 200 | Y | – | – | 308267 |
| 400 | Y | – | – | 297858 |

Size-specific combinations:

| | | | | |
|-------------|--------|---|---|-----------|
| | | | | Nº |
| ≤ 1400 | – | – | – | – |
| 1401 – 1600 | 200 KU | – | – | 308267 |
| 1601 – 2000 | – | – | – | – |
| 2001 – 2200 | 200 KU | – | – | 308267 |
| 2201 – 2400 | 400 KU | – | – | 297858 |
| 2401 – 2500 | 200 KU | – | – | 308267 |

Centre lock (CL)

| | | | | | |
|-------------------------------------|---|---|---|-----------|---|
| [5] CL component, horizontal | | | | | 4 |
| | | | | Nº | |
| 200 | – | – | – | 308267 | |
| 344 | 1 | V | – | 572665 | |
| 480 | – | – | – | 245729 | |
| 590 | – | – | – | 603442 | |
| 790 | 1 | E | – | 603444 | |
| 990 | 1 | E | – | 603447 | |
| 1190 | 1 | E | – | 603462 | |
| 1440 | 1 | E | – | 603466 | |

Size-specific combinations:

| | | | | |
|-------|-----|---|---|-----------|
| | | | | Nº |
| ≤ 760 | 344 | 1 | V | 572665 |

| | | | | |
|-------------|------|---|---|-----------|
| | | | | Nº |
| 761 – 860 | 480 | – | – | 245729 |
| 861 – 1060 | 590 | – | – | 603442 |
| 1061 – 1260 | 790 | 1 | E | 603444 |
| 1261 – 1460 | 990 | 1 | E | 603447 |
| 1461 – 1660 | 1190 | 1 | E | 603462 |
| 1661 – 1910 | 1440 | 1 | E | 603466 |
| ≥ 1911 | 1440 | 1 | E | 603466 |
| | 200 | – | – | 308267 |

| | | | | | |
|--|---|---|---|-----------|---|
| [6] Centre lock component 130, horizontal | | | | | 4 |
| | | | | Nº | |
| 130 | Y | 1 | E | 764350 | |

| | | | | | | |
|---|---|---|---|-----------|--|---|
| [7] CL component, vertical, on the mullion | | | | | | 4 |
| | | | | Nº | | |
| 200 | Y | – | – | 308267 | | |
| | Y | 1 | E | 450821 | | |
| 400 | Y | – | – | 297858 | | |
| 600 | Y | 1 | E | 255282 | | |
| | N | 1 | E | 255281 | | |

Size-specific combinations:

| | | | | |
|-------------|--------|---|---|-----------|
| | | | | Nº |
| 1201 – 1800 | 600 | 1 | E | 255281 |
| 1801 – 2000 | 200 KU | – | – | 308267 |
| | 600 | 1 | E | 255281 |
| 2001 – 2200 | 400 KU | – | – | 297858 |
| | 600 | 1 | E | 255281 |
| 2201 – 2400 | 200 KU | 1 | E | 450821 |
| | 400 KU | – | – | 297858 |
| | 600 | 1 | E | 255281 |
| 2401 – 2500 | 200 KU | – | – | 308267 |
| | 600 KU | 1 | E | 255282 |
| | 200 KU | – | – | 308267 |
| | 600 | 1 | E | 255281 |

| | | | | |
|------------------------|-------|-----------|--|-----|
| [9] Roller unit | | | | 1-2 |
| | | Nº | | |
| 41 | Left | 821686 | | |
| | Right | 823733 | | |

| | | | |
|--------|--|---|---|
| | | | 1 |
| < 1060 | | 2 | |
| ≥ 1060 | | 3 | |

[10] Control unit, on the mullion side and in the centre → from page 158 1-2
Alternatively (on the mullion side):
Control unit set with Soft function (incl. activator) → from page 158 1



| | | | |
|----|-------|-----------|--|
| | | Nº | |
| 41 | Left | 821686 | |
| | Right | 823730 | |



[*] Control unit set with Soft function, on the locking side → *from page 158*  1
Alternatively:
[10] Control unit

Contents:

| [*] |  | # |
|------|---|---|
| [29] | Activator | 1 |
| [30] | Control unit with Soft function | 1 |

[11] Centre closer



|  |  | Nº |
|---|---|--------|
| 41 | Left | 821687 |
| | Right | 823736 |

| | |
|-------------|---|
| ≤ 1072 | 2 |
| 1073 – 1700 | 3 |
| 1701 – 2100 | 4 |
| > 2100 | 5 |

[12] MUL locking cam



|  | Nº |
|---|--------|
| 38.4 | 809614 |

| | |
|-------------|---|
| ≤ 1072 | 2 |
| 1073 – 1700 | 3 |
| 1701 – 2100 | 4 |
| > 2100 | 5 |



[15] SEC striker to prevent incorrect operation  1

|  | Nº |
|---|--------|
| SEC striker to prevent incorrect operation | 822796 |

[16] Parallel Sliding and Tilt&Slide handle – interior handle, lockable (200 mm handle length)  1
Sliding door handle – exterior recessed grip (43 mm distance), not sh.  1

[17] SEC striker

|  | Nº |
|---|--------|
| Screw-on | 798226 |

 



| | |
|-------------|---|
| ≤ 1072 | 2 |
| 1073 – 1700 | 3 |
| 1701 – 2100 | 4 |
| > 2100 | 5 |

[18] Buffer  2

|  | Nº |
|---|--------|
| 14 | 635307 |



[20] SEC MUL striker



|  | Nº |
|---|--------|
| SEC MUL striker | 828318 |

| | |
|-------------|---|
| ≤ 1072 | 2 |
| 1073 – 1700 | 3 |
| 1701 – 2100 | 4 |
| > 2100 | 5 |

[27] Cover cap for SEC MUL striker

|  |  | Nº |
|---|--|--------|
| R01.1 | Natural silver | 858400 |
| R05.3 | Medium bronze | 858402 |
| R06.2 | Jet black | 858401 |
| R07.2 | Traffic white | 858338 |

 

| | |
|-------------|---|
| ≤ 1072 | 2 |
| 1073 – 1700 | 3 |
| 1701 – 2100 | 4 |
| > 2100 | 5 |

[22] Drilling protection  1

|  | Nº |
|---|--------|
| Drilling protection | 770965 |

[24] Pin for anti-pushback function  2

|  | Nº |
|---|--------|
| 38 | 820048 |

[25] Centre closer for anti-pushback function  2

|  |  | Nº |
|---|---|--------|
| 41 | Left | 821687 |
| | Right | 823736 |

INFO
DIN L: order right components.
DIN R: order left components.

[26] Striker for anti-pushback function  2

|  | Nº |
|---|--------|
| Striker for anti-pushback function | 810279 |

[27] Cover cap for striker for anti-pushback function  2

|  |  | Nº |
|---|--|--------|
| R01.1 | Natural silver | 828482 |
| R05.3 | Medium bronze | 828483 |
| R06.2 | Jet black | 809717 |
| R07.2 | Traffic white | 819351 |



[33] Stopper, cannot be used in conjunction with a control unit with SoftOpen and SoftStop on the mullion side.  1



Nº

Stopper

800196

Alternatively

[2b] VT espagnolette, lockable (alternative to 2a)  1



Nº

| | | | | | | | | |
|----|-------------|------|-----|------|---|---|----------|--------|
| 35 | 1801 – 2400 | 1890 | 200 | 1000 | 2 | V | Roto Sil | 798034 |
| | 2401 – 2500 | 2290 | 200 | 1000 | 2 | V | Roto Sil | 798055 |

[37] Rubber buffer (alternative to 33)  2



Nº

14

729179

Optional

[35] Brush holder



Nº

Brush holder

809520



< 1060

2

≥ 1060

3

[80] Tilt protection device; for application ranges SRH:SRW = > 2:1 up to max. 3:1; can only be used without control unit with Soft function.  2



Nº

Tilt protection device

897049

SKG info clip**, not sh.  1



Nº

| | | | | |
|-----------------|-------------------------------|-------|---------------|--------|
| SKG** info clip | For clipping onto the gearbox | R07.2 | Traffic white | 331459 |
|-----------------|-------------------------------|-------|---------------|--------|

4.2.3.3 Diagram C

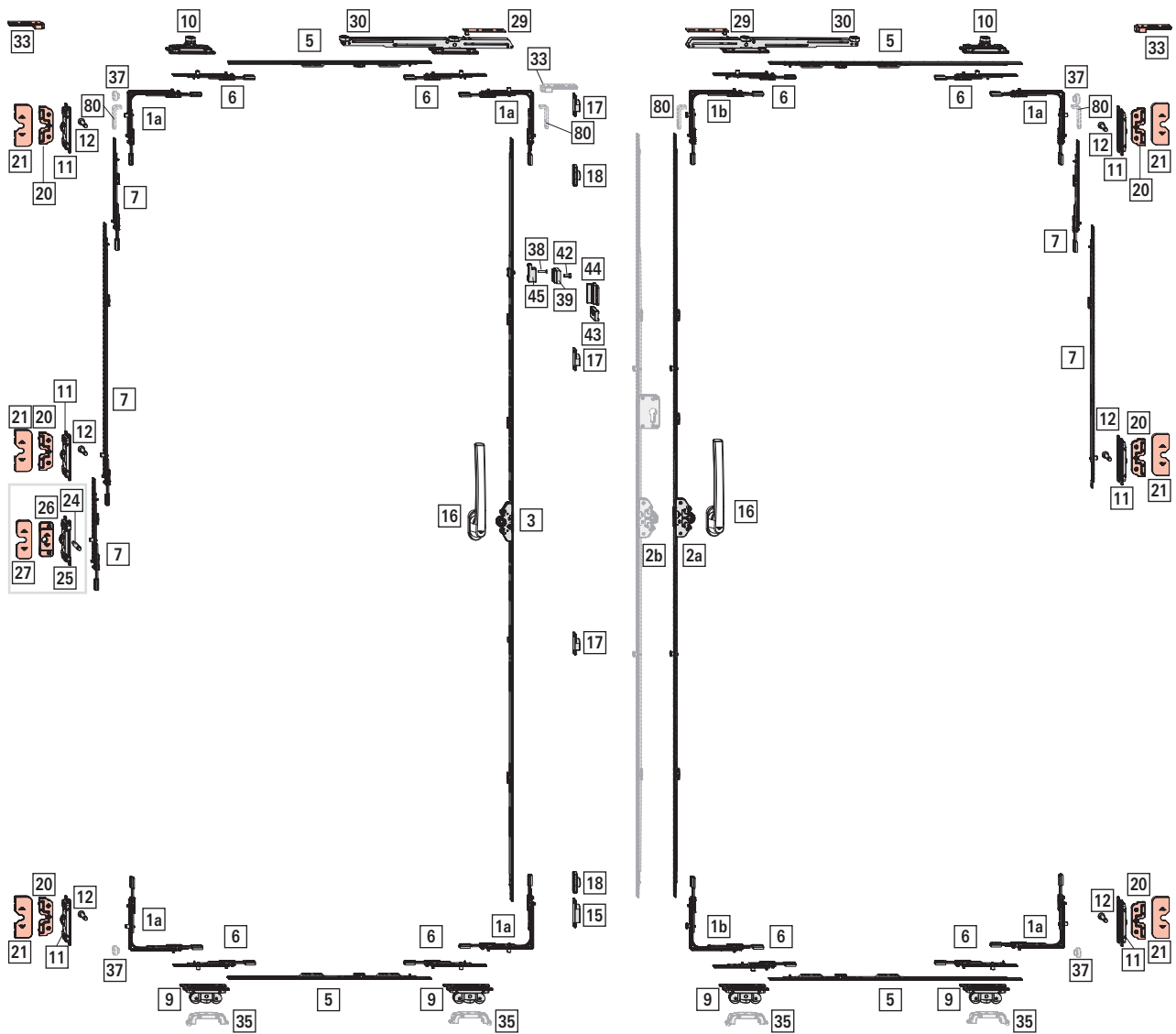



Application range

SRW: 710 – 1500 mm

SRH: 600 – 2500 mm

S.kg: max. 200 kg

| | | | |
|--------------------------|------------|--|---|
| [1a] Corner drive | With E cam | | 6 |
| [1b] | With V cam | | 2 |

| | | Nº |
|---|---|--------|
| 1 | E | 260275 |
| 1 | V | 260272 |

[2a] VT espagnolette

| | | | | | | | | Nº |
|----|-------------|------|-----|------|---|---|----------|--------|
| 35 | 600 – 800 | 690 | 200 | 263 | – | – | Roto Sil | 799045 |
| | 801 – 1000 | 890 | 200 | 413 | – | – | Roto Sil | 798027 |
| | 1001 – 1200 | 1090 | 200 | 513 | 1 | V | Roto Sil | 798028 |
| | 1201 – 1600 | 1290 | 200 | 563 | 1 | V | Roto Sil | 798030 |
| | 1601 – 1800 | 1690 | 200 | 563 | 1 | V | Roto Sil | 798031 |
| | 1801 – 2400 | 1890 | 200 | 1000 | 2 | V | Roto Sil | 798032 |
| | 2401 – 2500 | 2290 | 200 | 1000 | 2 | V | Roto Sil | 798033 |

[3] VT espagnolette, second opening sash

| | | | | | | | | Nº |
|----|-------------|------|-----|------|---|---|----------|--------|
| 25 | 600 – 800 | 690 | 200 | 263 | – | – | Roto Sil | 793942 |
| | 801 – 1000 | 890 | 200 | 413 | – | – | Roto Sil | 793943 |
| | 1001 – 1200 | 1090 | 200 | 513 | – | – | Roto Sil | 809691 |
| | 1201 – 1600 | 1290 | 200 | 563 | – | – | Roto Sil | 809692 |
| | 1601 – 1800 | 1690 | 200 | 563 | – | – | Roto Sil | 809694 |
| | 1801 – 2400 | 1890 | 200 | 1000 | – | – | Roto Sil | 809695 |
| | 2401 – 2500 | 2290 | 200 | 1000 | – | – | Roto Sil | 809697 |

Espagnolette extension, (SRH > 1401 mm; not sh.)

| | | | | Nº |
|-----|---|---|---|--------|
| 200 | Y | – | – | 308267 |
| 400 | Y | – | – | 297858 |

Size-specific combinations:

| | | | | Nº |
|-------------|--------|---|---|--------|
| ≤ 1400 | – | – | – | – |
| 1401 – 1600 | 200 KU | – | – | 308267 |
| 1601 – 2000 | – | – | – | – |
| 2001 – 2200 | 200 KU | – | – | 308267 |
| 2201 – 2400 | 400 KU | – | – | 297858 |
| 2401 – 2500 | 200 KU | – | – | 308267 |

Centre lock (CL)

[5] CL component, horizontal

| | | | Nº |
|-----|---|---|--------|
| 200 | – | – | 308267 |
| 344 | 1 | V | 572665 |

| | | | Nº |
|------|---|---|--------|
| 480 | – | – | 245729 |
| 590 | – | – | 603442 |
| 790 | 1 | E | 603444 |
| 990 | 1 | E | 603447 |
| 1190 | 1 | E | 603462 |
| 1440 | 1 | E | 603466 |

Size-specific combinations:

First or second opening sash

| | | | | Nº |
|-------------|------|---|---|--------|
| ≤ 760 | 344 | 1 | V | 572665 |
| 761 – 860 | 480 | – | – | 245729 |
| 861 – 1060 | 590 | – | – | 603442 |
| 1061 – 1260 | 790 | 1 | E | 603444 |
| 1261 – 1460 | 990 | 1 | E | 603447 |
| 1461 – 1660 | 1190 | 1 | E | 603462 |
| 1661 – 1910 | 1440 | 1 | E | 603466 |
| ≥ 1911 | 1440 | 1 | E | 603466 |
| | 200 | – | – | 308267 |

[6] Centre lock component 130, horizontal and vertical

| | | | | Nº |
|-----|---|---|---|--------|
| 130 | Y | 1 | E | 764350 |

[7] CL component, vertical, on the mullion

| | | | | Nº |
|-----|---|---|---|--------|
| 200 | Y | – | – | 308267 |
| | Y | 1 | E | 450821 |
| 400 | Y | – | – | 297858 |
| 600 | Y | 1 | E | 255282 |
| | N | 1 | E | 255281 |





Size-specific combinations:

First opening sash:

| | | | | Nº |
|-------------|--------|---|---|--------|
| 1201 – 1800 | 600 | 1 | E | 255281 |
| 1801 – 2000 | 200 KU | – | – | 308267 |
| | 600 | 1 | E | 255281 |
| 2001 – 2200 | 400 KU | – | – | 297858 |
| | 600 | 1 | E | 255281 |
| 2201 – 2400 | 200 KU | 1 | E | 450821 |
| | 400 KU | – | – | 297858 |
| | 600 | 1 | E | 255281 |
| 2401 – 2500 | 200 KU | – | – | 308267 |
| | 600 KU | 1 | E | 255282 |
| | 200 KU | – | – | 308267 |
| | 600 | 1 | E | 255281 |

Second opening sash:

| | | | | Nº |
|------------|--------|---|---|--------|
| 600 – 1200 | 200 KU | 1 | E | 450821 |

|  |  |  |  | Nº |
|---|---|---|---|--------|
| 1201 – 1800 | 600 KU | 1 | E | 255282 |
| | 200 KU | 1 | E | 450821 |
| 1801 – 2000 | 200 KU | – | – | 308267 |
| | 600 KU | 1 | E | 255282 |
| 2001 – 2200 | 200 KU | 1 | E | 450821 |
| | 400 KU | – | – | 297858 |
| 2201 – 2400 | 600 KU | 1 | E | 255282 |
| | 200 KU | 1 | E | 450821 |
| 2401 – 2500 | 200 KU | – | – | 308267 |
| | 600 KU | 1 | E | 255282 |
| | 200 KU | – | – | 308267 |
| | 600 KU | 1 | E | 255282 |
| | 200 KU | 1 | E | 450821 |

[9] Roller unit

|  |  | Nº |
|--|--|--------|
| 41 | Left | 821686 |
| | Right | 823733 |



|  |  |
|---|---|
| < 1060 | 4 |
| ≥ 1060 | 6 |

[10] Control unit, on the mullion side and in the centre → *from page 158*  2-4
Alternatively (on the mullion side):
Control unit set with Soft function (incl. activator) → *from page 158*  1-2

|  |  | Nº |
|---|---|--------|
| 41 | Left | 821685 |
| | Right | 823730 |

[*] Control unit set with Soft function, on the locking side → *from page 158*  2
Alternatively:
[10] Control unit

Contents:

|  |  | # |
|---|---|---|
| [29] | Activator | 1 |
| [30] | Control unit with Soft function | 1 |

[11] Centre closer

|  |  | Nº |
|---|---|--------|
| 41 | Left | 821687 |

|  |  | Nº |
|---|---|--------|
| | Right | 823736 |

|  |  |
|---|---|
| ≤ 1200 | 4 |
| 1201 – 2400 | 6 |
| > 2400 | 8 |



[12] MUL locking cam

|  | Nº |
|---|--------|
| 38.4 | 809614 |

|  |  |
|---|---|
| ≤ 1200 | 4 |
| 1201 – 2400 | 6 |
| > 2400 | 8 |



[15] Striker to prevent incorrect operation  1

|  | Nº |
|---|--------|
| Striker to prevent incorrect operation | 822789 |

[16] Parallel Sliding and Tilt&Slide handle – interior handle (200 mm handle length)  2
Sliding door handle – exterior recessed grip (43 mm distance), not sh.  2

[17] Striker

|  | Nº |
|---|--------|
| Screw-on | 744579 |

|  |  |
|---|---|
| ≤ 1200 | 2 |
| 1201 – 2400 | 3 |
| > 2400 | 4 |

[18] Buffer  2



|  | Nº |
|---|--------|
| 14 | 635307 |

[20] MUL striker





|  | Nº |
|---|--------|
| Screw-on | 793493 |

|  |  |
|---|---|
| ≤ 1200 | 4 |
| 1201 – 2400 | 6 |
| > 2400 | 8 |



[21] Cover cap for MUL striker, only in combination with MUL striker, screw-on.

|  |  | Nº |
|---|--|--------|
| R01.1 | Natural silver | 819632 |
| R05.3 | Medium bronze | 819631 |
| R06.2 | Jet black | 798979 |



| | | |
|---|---|---|
|  |  | Nº |
| R07.2 | Traffic white | 808054 |
|  | |  |
| ≤ 1200 | | 4 |
| 1201 – 2400 | | 6 |
| > 2400 | | 8 |

[*] Operating sequence control set  1
SRH ≥ 1200 mm, profile-related

| | | |
|---|---|---------|
|  |  | Nº |
| PVC | Gealan Smoovio | 2009503 |

| | | |
|------------|---|----------|
| [*] |  | # |
| [38] | Countersunk screw, M5 x 20 | 1 |
| [39] | Stop, second opening sash | 1 |
| [42] | Cylinder screw | 1 |
| [43] | Anti-lifting device | 1 |
| [44] | Stop, first opening sash | 1 |
| [45] | Adapter | 1 |

[24] Pin for anti-pushback function  1

| | |
|--|--------|
|  | Nº |
| 38 | 820048 |

[25] Centre closer for anti-pushback function  1

| | | |
|---|---|--------|
|  |  | Nº |
| 41 | Left | 821687 |
| | Right | 823736 |



INFO

DIN L: order right components.
DIN R: order left components.

[26] Striker for anti-pushback function  1

| | |
|---|--------|
|  | Nº |
| Striker for anti-pushback function | 810279 |

[27] Cover cap for striker for anti-pushback function  1









| | | |
|---|---|--------|
|  |  | Nº |
| R01.1 | Natural silver | 828482 |
| R05.3 | Medium bronze | 828483 |
| R06.2 | Jet black | 809717 |
| R07.2 | Traffic white | 819351 |

[33] Stopper, cannot be used in conjunction with a control unit with SoftOpen / SoftClose together with SoftStop on the mullion side / SoftStop on the locking side.  2

| | |
|---|--------|
|  | Nº |
| Stopper | 800196 |

Alternatively

[2b] VT espagnolette, lockable (alternative to 2a) → from page 146  1



| | | | | | | | | |
|---|---|--|---|---|---|---|---|--------|
|  |  |  |  |  |  |  |  | Nº |
| 35 | 1801 – 2400 | 1890 | 200 | 1000 | 2 | V | Roto Sil | 798034 |
| | 2401 – 2500 | 2290 | 200 | 1000 | 2 | V | Roto Sil | 798055 |

[37] Rubber buffer (alternative to 33)  4

| | |
|---|--------|
|  | Nº |
| 14 | 729179 |

Optional

[35] Brush holder

| | |
|---|---|
|  | Nº |
| Brush holder | 809520 |
|  |  |
| < 1060 | 4 |
| ≥ 1060 | 6 |

[80] Tilt protection device; for application ranges SRH:SRW = > 2:1 up to max. 3:1; can only be used without control unit with Soft function.  4

| | |
|---|--------|
|  | Nº |
| Tilt protection device | 897049 |

4.2.4 Rehau | Synego Slide

4.2.4.1 Diagram A





Application range

SRW: 710 – 2000 mm

SRH: 600 – 2500 mm

S.kg: max. 250 kg

| | | | |
|--------------------------|------------|--|---|
| [1a] Corner drive | With E cam | | 2 |
| [1b] | With V cam | | 2 |

| | | Nº |
|---|---|--------|
| 1 | E | 260275 |
| 1 | V | 260272 |

[2a] VT espagnolette

| | | | | | | | | Nº |
|----|-------------|------|-----|------|---|---|----------|--------|
| 40 | 600 – 800 | 690 | 200 | 263 | – | – | Roto Sil | 792143 |
| | 801 – 1000 | 890 | 200 | 413 | – | – | Roto Sil | 792144 |
| | 1001 – 1200 | 1090 | 200 | 513 | 1 | V | Roto Sil | 792185 |
| | 1201 – 1600 | 1290 | 200 | 563 | 1 | V | Roto Sil | 792188 |
| | 1601 – 1800 | 1690 | 200 | 563 | 1 | V | Roto Sil | 792190 |
| | 1801 – 2400 | 1890 | 200 | 1000 | 2 | V | Roto Sil | 792191 |
| | 2401 – 2500 | 2290 | 200 | 1000 | 2 | V | Roto Sil | 792193 |

Espagnolette extension, (SRH > 1401 mm; not sh.)

| | | | | Nº |
|-----|---|---|---|--------|
| 200 | Y | – | – | 308267 |
| 400 | Y | – | – | 297858 |

Size-specific combinations:

| | | | | Nº |
|-------------|--------|---|---|--------|
| ≤ 1400 | – | – | – | – |
| 1401 – 1600 | 200 KU | – | – | 308267 |
| 1601 – 2000 | – | – | – | – |
| 2001 – 2200 | 200 KU | – | – | 308267 |
| 2201 – 2400 | 400 KU | – | – | 297858 |
| 2401 – 2500 | 200 KU | – | – | 308267 |

Centre lock (CL)

[5] CL component, horizontal

| | | | Nº |
|------|---|---|--------|
| 200 | – | – | 308267 |
| 344 | 1 | V | 572665 |
| 480 | – | – | 245729 |
| 590 | – | – | 603442 |
| 790 | 1 | E | 603444 |
| 990 | 1 | E | 603447 |
| 1190 | 1 | E | 603462 |
| 1440 | 1 | E | 603466 |

Size-specific combinations:

| | | | | Nº |
|-------|-----|---|---|--------|
| ≤ 760 | 344 | 1 | V | 572665 |

| | | | | Nº |
|-------------|------|---|---|--------|
| 761 – 860 | 480 | – | – | 245729 |
| 861 – 1060 | 590 | – | – | 603442 |
| 1061 – 1260 | 790 | 1 | E | 603444 |
| 1261 – 1460 | 990 | 1 | E | 603447 |
| 1461 – 1660 | 1190 | 1 | E | 603462 |
| 1661 – 1910 | 1440 | 1 | E | 603466 |
| ≥ 1911 | 1440 | 1 | E | 603466 |
| | 200 | – | – | 308267 |

[6] Centre lock component 130, horizontal

| | | | | Nº |
|-----|---|---|---|--------|
| 130 | Y | 1 | E | 764350 |

[7] CL component, vertical, on the mullion

| | | | | Nº |
|-----|---|---|---|--------|
| 200 | Y | – | – | 308267 |
| | Y | 1 | E | 450821 |
| 400 | Y | – | – | 297858 |
| 600 | Y | 1 | E | 255282 |
| | N | 1 | E | 255281 |

Size-specific combinations:

| | | | | Nº |
|-------------|--------|---|---|--------|
| 1201 – 1800 | 600 | 1 | E | 255281 |
| 1801 – 2000 | 200 KU | – | – | 308267 |
| | 600 | 1 | E | 255281 |
| 2001 – 2200 | 400 KU | – | – | 297858 |
| | 600 | 1 | E | 255281 |
| 2201 – 2400 | 200 KU | 1 | E | 450821 |
| | 400 KU | – | – | 297858 |
| | 600 | 1 | E | 255281 |
| 2401 – 2500 | 200 KU | – | – | 308267 |
| | 600 KU | 1 | E | 255282 |
| | 200 KU | – | – | 308267 |
| | 600 | 1 | E | 255281 |

[9] Roller unit

| | | Nº |
|----|-------|--------|
| 41 | Left | 821686 |
| | Right | 823733 |

| < 1060 | 2 |
|--------|---|
| ≥ 1060 | 3 |

[10] Control unit, on the mullion side and in the centre → from page 158

Alternatively (on the mullion side):

Control unit set with Soft function (incl. activator) → from page 158

| | | Nº |
|----|-------|--------|
| 41 | Left | 821686 |
| | Right | 823730 |

[*] Control unit set with Soft function, on the locking side → *from page 158*  1
Alternatively:
[10] Control unit 

Contents:

| [*] |  | # |
|------|---|---|
| [29] | Activator | 1 |
| [30] | Control unit with Soft function | 1 |

[11] Centre closer

|  |  | Nº |
|---|---|--------|
| 41 | Left | 821687 |
| | Right | 823736 |

|  |  |
|---|---|
| ≤ 1200 | 2 |
| 1201 – 2400 | 3 |
| > 2400 | 4 |



[12] MUL locking cam

|  | Nº |
|---|--------|
| 37.5 | 836782 |

|  |  |
|---|---|
| ≤ 1200 | 2 |
| 1201 – 2400 | 3 |
| > 2400 | 4 |

[15] Striker to prevent incorrect operation  1

|  | Nº |
|---|--------|
| Striker to prevent incorrect operation | 822789 |

[16] Parallel Sliding and Tilt&Slide handle – interior handle (200 mm handle length)  1
Sliding door handle – exterior recessed grip (43 mm distance), not sh.  1

[17] Striker

|  | Nº |
|---|--------|
| Screw-on | 744579 |

|  |  |
|---|---|
| ≤ 1200 | 2 |
| 1201 – 2400 | 3 |
| > 2400 | 4 |

[18] Buffer  2



|  | Nº |
|---|--------|
| 14 | 635307 |

[20] MUL striker

|  | Nº |
|---|--------|
| Screw-on | 793493 |

|  |  |
|---|---|
| ≤ 1200 | 2 |
| 1201 – 2400 | 3 |
| > 2400 | 4 |

[21] Cover cap for MUL striker, only in combination with MUL striker, screw-on.

|  |  | Nº |
|---|--|--------|
| R01.1 | Natural silver | 819632 |
| R05.3 | Medium bronze | 819631 |
| R06.2 | Jet black | 798979 |
| R07.2 | Traffic white | 808054 |

|  |  |
|---|---|
| ≤ 1200 | 2 |
| 1201 – 2400 | 3 |
| > 2400 | 4 |

[33] Stopper, cannot be used in conjunction with a control unit with SoftOpen and SoftStop on the mullion side.  1

|  | Nº |
|---|--------|
| Stopper | 800196 |

Alternatively

[2b] VT espagnolette, lockable (alternative to 2a)  1

|  |  |  |  |  |  |  |  |  | Nº |
|---|---|--|---|---|---|---|---|---|----|
| 40 | 1801 – 2400 | 1890 | 200 | 1000 | 2 | V | Roto Sil | 795603 | |
| | 2401 – 2500 | 2290 | 200 | 1000 | 2 | V | Roto Sil | 795604 | |

[37] Rubber buffer (alternative to 33)  2

|  | Nº |
|---|--------|
| 14 | 729179 |

Optional

[35] Brush holder

|  | Nº |
|---|--------|
| Brush holder | 809520 |

|  |  |
|---|---|
| < 1060 | 2 |
| ≥ 1060 | 3 |



[80] **Tilt protection device**; for application ranges SRH:SRW = > 2:1 up to max. 3:1; can only be used without control unit with Soft function.  2



Nº

Tilt protection device

897049

4.2.4.2 Diagram A – RC 2 / RC 2 N





Application range

SRW: 710 – 2000 mm

SRH: 1072 – 2500 mm

S.kg: max. 250 kg

| | | | |
|--------------------------|------------|--|---|
| [1a] Corner drive | With E cam | | 2 |
| [1b] | With V cam | | 2 |

| | | Nº |
|---|---|--------|
| 1 | E | 260275 |
| 1 | V | 260272 |

[2a] VT espagnolette

| | | | | | | | | Nº |
|----|-------------|------|-----|------|---|---|----------|--------|
| 40 | 600 – 800 | 690 | 200 | 263 | – | – | Roto Sil | 792143 |
| | 801 – 1000 | 890 | 200 | 413 | – | – | Roto Sil | 792144 |
| | 1001 – 1200 | 1090 | 200 | 513 | 1 | V | Roto Sil | 792185 |
| | 1201 – 1600 | 1290 | 200 | 563 | 1 | V | Roto Sil | 792188 |
| | 1601 – 1800 | 1690 | 200 | 563 | 1 | V | Roto Sil | 792190 |
| | 1801 – 2400 | 1890 | 200 | 1000 | 2 | V | Roto Sil | 792191 |
| | 2401 – 2500 | 2290 | 200 | 1000 | 2 | V | Roto Sil | 792193 |

Espagnolette extension, (SRH > 1401 mm; not sh.)

| | | | | Nº |
|-----|---|---|---|--------|
| 200 | Y | – | – | 308267 |
| 400 | Y | – | – | 297858 |

Size-specific combinations:

| | | | | Nº |
|-------------|--------|---|---|--------|
| ≤ 1400 | – | – | – | – |
| 1401 – 1600 | 200 KU | – | – | 308267 |
| 1601 – 2000 | – | – | – | – |
| 2001 – 2200 | 200 KU | – | – | 308267 |
| 2201 – 2400 | 400 KU | – | – | 297858 |
| 2401 – 2500 | 200 KU | – | – | 308267 |

Centre lock (CL)

[5] CL component, horizontal

| | | | Nº |
|------|---|---|--------|
| 200 | – | – | 308267 |
| 344 | 1 | V | 572665 |
| 480 | – | – | 245729 |
| 590 | – | – | 603442 |
| 790 | 1 | E | 603444 |
| 990 | 1 | E | 603447 |
| 1190 | 1 | E | 603462 |
| 1440 | 1 | E | 603466 |

Size-specific combinations:

| | | | | Nº |
|-----------|-----|---|---|--------|
| ≤ 760 | 344 | 1 | V | 572665 |
| 761 – 860 | 480 | – | – | 245729 |

| | | | | Nº |
|-------------|------|---|---|--------|
| 861 – 1060 | 590 | – | – | 603442 |
| 1061 – 1260 | 790 | 1 | E | 603444 |
| 1261 – 1460 | 990 | 1 | E | 603447 |
| 1461 – 1660 | 1190 | 1 | E | 603462 |
| 1661 – 1910 | 1440 | 1 | E | 603466 |
| ≥ 1911 | 1440 | 1 | E | 603466 |
| | 200 | – | – | 308267 |

[6] Centre lock component 130, horizontal

| | | | | Nº |
|-----|---|---|---|--------|
| 130 | Y | 1 | E | 764350 |

[7] CL component, vertical, on the mullion

| | | | | Nº |
|-----|---|---|---|--------|
| 200 | Y | – | – | 308267 |
| | Y | 1 | E | 450821 |
| 400 | Y | – | – | 297858 |
| 600 | Y | 1 | E | 255282 |
| | N | 1 | E | 255281 |

Size-specific combinations:

| | | | | Nº |
|-------------|--------|---|---|--------|
| 1201 – 1800 | 600 | 1 | E | 255281 |
| 1801 – 2000 | 200 KU | – | – | 308267 |
| | 600 | 1 | E | 255281 |
| 2001 – 2200 | 400 KU | – | – | 297858 |
| | 600 | 1 | E | 255281 |
| 2201 – 2400 | 200 KU | 1 | E | 450821 |
| | 400 KU | – | – | 297858 |
| | 600 | 1 | E | 255281 |
| 2401 – 2500 | 200 KU | – | – | 308267 |
| | 600 KU | 1 | E | 255282 |
| | 200 KU | – | – | 308267 |
| | 600 | 1 | E | 255281 |

[9] Roller unit

| | | Nº |
|----|-------|--------|
| 41 | Left | 821686 |
| | Right | 823733 |

| | Nº |
|--------|----|
| < 1060 | 2 |
| ≥ 1060 | 3 |

[10] Control unit, on the mullion side and in the centre → from page 158

Alternatively (on the mullion side):
Control unit set with Soft function (incl. activator) → from page 158

| | | Nº |
|----|-------|--------|
| 41 | Left | 821685 |
| | Right | 823730 |

[*] Control unit set with Soft function, on the locking side → from page 158  1
Alternatively:
[10] Control unit

Contents:

| [*] | | # |
|------|---------------------------------|---|
| [29] | Activator | 1 |
| [30] | Control unit with Soft function | 1 |

[11] Centre closer

| | | Nº |
|----|-------|--------|
| 41 | Left | 821687 |
| | Right | 823736 |

| ≤ 1072 | | 2 |
|-------------|--|---|
| 1073 – 1700 | | 3 |
| 1701 – 2100 | | 4 |
| > 2100 | | 5 |

[12] MUL locking cam

| | Nº |
|------|--------|
| 37.5 | 836782 |

| ≤ 1072 | | 2 |
|-------------|--|---|
| 1073 – 1700 | | 3 |
| 1701 – 2100 | | 4 |
| > 2100 | | 5 |

[15] SEC striker to prevent incorrect operation  1

| | Nº |
|--|--------|
| SEC striker to prevent incorrect operation | 822796 |

[16] Parallel Sliding and Tilt&Slide handle – interior handle, lockable (200 mm handle length)  1

Sliding door handle – exterior recessed grip (43 mm distance), not sh.  1

[17] SEC striker

| | Nº |
|----------|--------|
| Screw-on | 798226 |

| ≤ 1072 | | 2 |
|-------------|--|---|
| 1073 – 1700 | | 3 |
| 1701 – 2100 | | 4 |
| > 2100 | | 5 |

[18] Buffer  2

| | Nº |
|----|--------|
| 14 | 635307 |

[20] SEC MUL striker

| | Nº |
|------|--------|
| 31.6 | 833688 |

| ≤ 1072 | | 2 |
|-------------|--|---|
| 1073 – 1700 | | 3 |
| 1701 – 2100 | | 4 |
| > 2100 | | 5 |

[22] Drilling protection  1

| | Nº |
|---------------------|--------|
| Drilling protection | 770965 |

[24] Pin for anti-pushback function  2

| | Nº |
|------|--------|
| 37.5 | 837714 |

[25] Centre closer for anti-pushback function  2

| | | Nº |
|----|-------|--------|
| 41 | Left | 821687 |
| | Right | 823736 |

INFO
DIN L: order right components.
DIN R: order left components.

[26] Striker for anti-pushback function  2

| | Nº |
|------------------------------------|--------|
| Striker for anti-pushback function | 810279 |

[27] Cover cap for SEC MUL striker / striker for anti-pushback function

| | | Nº |
|-------|----------------|--------|
| R01.1 | Natural silver | 828482 |
| R05.3 | Medium bronze | 828483 |
| R06.2 | Jet black | 809717 |
| R07.2 | Traffic white | 819351 |

| ≤ 1072 | | 2 |
|-------------|--|---|
| 1073 – 1700 | | 3 |
| 1701 – 2100 | | 4 |
| > 2100 | | 5 |

[33] Stopper, cannot be used in conjunction with a control unit with SoftOpen and SoftStop on the mullion side.  1

| | Nº |
|---------|--------|
| Stopper | 800196 |



[34] Packer; profile-related quantity ^[7]

| | |
|--------|--------|
| | Nº |
| Packer | 800197 |

Alternatively

[2b] VT espagnolette, lockable (alternative to 2a)

| | |
|----|---|
| | Nº |
| 40 | 1801 – 2400 1890 200 1000 2 V Roto Sil 795603 |
| | 2401 – 2500 2290 200 1000 2 V Roto Sil 795604 |
| 35 | 1801 – 2400 1890 200 1000 2 V Roto Sil 798034 |
| | 2401 – 2500 2290 200 1000 2 V Roto Sil 798055 |

[11] Centre closer, adjustable

| | |
|-------------|--------------|
| | Nº |
| 41 | Left 823751 |
| | Right 823752 |
| | |
| ≤ 1072 | 2 |
| 1073 – 1700 | 3 |
| 1701 – 2100 | 4 |
| > 2100 | 5 |

[12] MUL locking cam, adjustable

| | | |
|-------------------------------|----|--------|
| | | Nº |
| Gasket compression adjustable | 36 | 895972 |
| | | |
| ≤ 1072 | 2 | |
| 1073 – 1700 | 3 | |
| 1701 – 2100 | 4 | |
| > 2100 | 5 | |

[25] Centre closer, adjustable, for anti-pushback function

| | |
|----|--------------|
| | Nº |
| 41 | Left 823751 |
| | Right 823752 |



INFO

DIN L: order right components.

DIN R: order left components.

[24] Pin, adjustable, for anti-pushback function

| | | |
|-------------------------------|----|--------|
| | | Nº |
| Gasket compression adjustable | 36 | 895999 |

[37] Rubber buffer (alternative to 33)

| | |
|----|--------|
| | Nº |
| 14 | 729179 |

Optional

[35] Brush holder

| | |
|--------------|--------|
| | Nº |
| Brush holder | 809520 |
| | |
| < 1060 | 2 |
| ≥ 1060 | 3 |

[80] Tilt protection device; for application ranges SRH:SRW = > 2:1 up to max. 3:1; can only be used without control unit with Soft function.

| | |
|------------------------|--------|
| | Nº |
| Tilt protection device | 897049 |

SKG info clip, not sh.**

| | | | | |
|-----------------|-------------------------------|-------|---------------|--------|
| | | | | Nº |
| SKG** info clip | For clipping onto the gearbox | R07.2 | Traffic white | 331459 |

[7] Only use the number of packers that is specified in the profile assessment.

4.2.5 Salamander | evolutionDrive Plus+

4.2.5.1 Diagram A

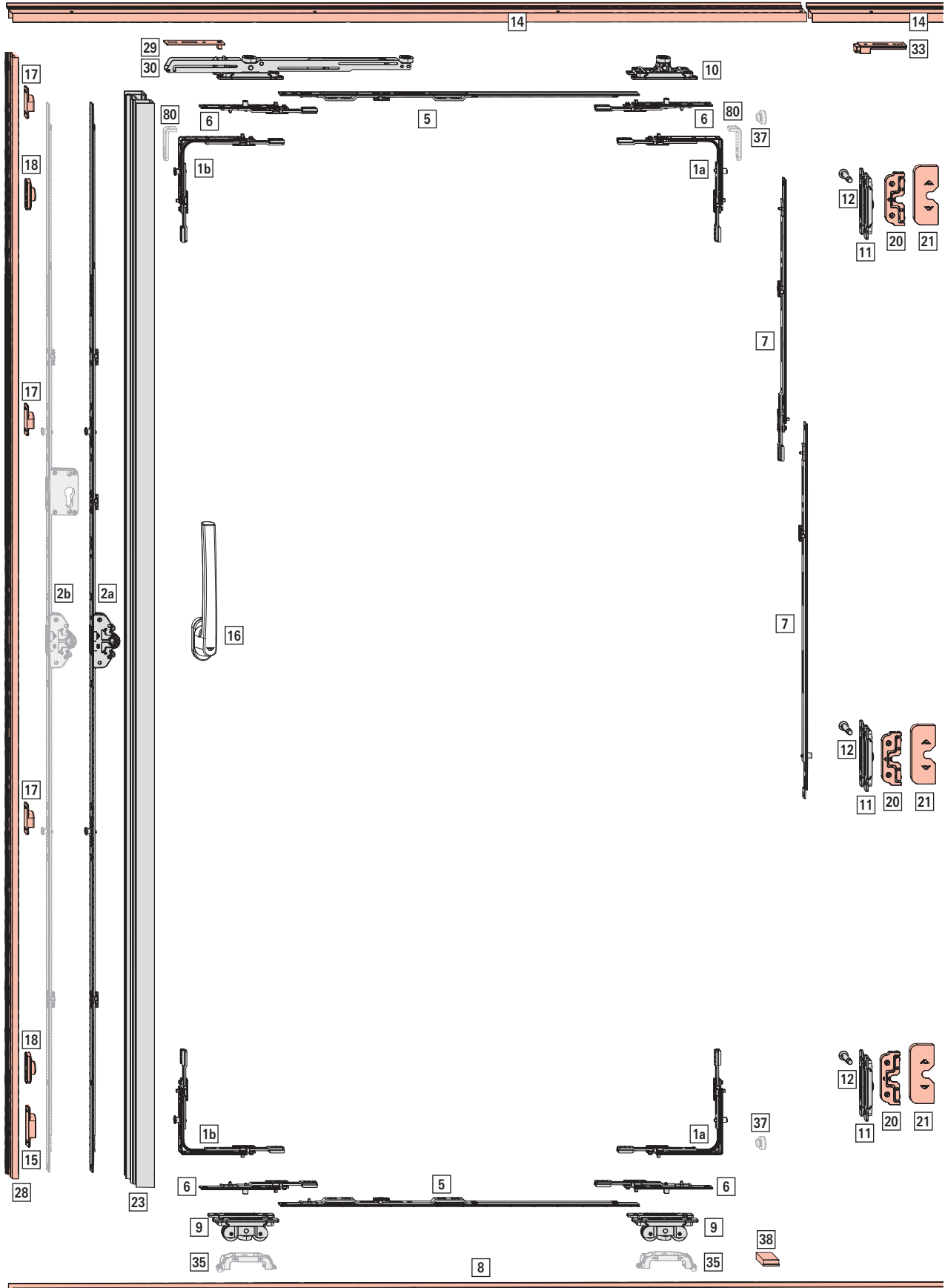



Application range

SRW: 710 – 2000 mm

SRH: 600 – 2500 mm

S.kg: max. 250 kg

| | | | |
|--------------------------|------------|--|---|
| [1a] Corner drive | With E cam | | 2 |
| [1b] | With V cam | | 2 |

| | | Nº |
|---|---|--------|
| 1 | E | 260275 |
| 1 | V | 260272 |

[2a] VT espagnolette

| | | | | | | | | Nº |
|----|-------------|------|-----|------|---|---|----------|--------|
| 35 | 600 – 800 | 690 | 200 | 263 | – | – | Roto Sil | 799045 |
| | 801 – 1000 | 890 | 200 | 413 | – | – | Roto Sil | 798027 |
| | 1001 – 1200 | 1090 | 200 | 513 | 1 | V | Roto Sil | 798028 |
| | 1201 – 1600 | 1290 | 200 | 563 | 1 | V | Roto Sil | 798030 |
| | 1601 – 1800 | 1690 | 200 | 563 | 1 | V | Roto Sil | 798031 |
| | 1801 – 2400 | 1890 | 200 | 1000 | 2 | V | Roto Sil | 798032 |
| | 2401 – 2500 | 2290 | 200 | 1000 | 2 | V | Roto Sil | 798033 |

Espagnolette extension, (SRH > 1401 mm; not sh.)

| | | | | Nº |
|-----|---|---|---|--------|
| 200 | Y | – | – | 308267 |
| 400 | Y | – | – | 297858 |

Size-specific combinations:

| | | | | Nº |
|-------------|--------|---|---|--------|
| ≤ 1400 | – | – | – | – |
| 1401 – 1600 | 200 KU | – | – | 308267 |
| 1601 – 2000 | – | – | – | – |
| 2001 – 2200 | 200 KU | – | – | 308267 |
| 2201 – 2400 | 400 KU | – | – | 297858 |
| 2401 – 2500 | 200 KU | – | – | 308267 |

Centre lock (CL)

[5] CL component, horizontal

| | | | Nº |
|------|---|---|--------|
| 200 | – | – | 308267 |
| 344 | 1 | V | 572665 |
| 480 | – | – | 245729 |
| 590 | – | – | 603442 |
| 790 | 1 | E | 603444 |
| 990 | 1 | E | 603447 |
| 1190 | 1 | E | 603462 |
| 1440 | 1 | E | 603466 |

Size-specific combinations:

| | | | | Nº |
|-------|-----|---|---|--------|
| ≤ 760 | 344 | 1 | V | 572665 |

| | | | | Nº |
|-------------|------|---|---|--------|
| 761 – 860 | 480 | – | – | 245729 |
| 861 – 1060 | 590 | – | – | 603442 |
| 1061 – 1260 | 790 | 1 | E | 603444 |
| 1261 – 1460 | 990 | 1 | E | 603447 |
| 1461 – 1660 | 1190 | 1 | E | 603462 |
| 1661 – 1910 | 1440 | 1 | E | 603466 |
| ≥ 1911 | 1440 | 1 | E | 603466 |
| | 200 | – | – | 308267 |

[6] Centre lock component 130, horizontal

| | | | | Nº |
|-----|---|---|---|--------|
| 130 | Y | 1 | E | 764350 |

[7] CL component, vertical, on the mullion

| | | | | Nº |
|-----|---|---|---|--------|
| 200 | Y | – | – | 308267 |
| | Y | 1 | E | 450821 |
| 400 | Y | – | – | 297858 |
| 600 | Y | 1 | E | 255282 |
| | N | 1 | E | 255281 |

Size-specific combinations:

| | | | | Nº |
|-------------|--------|---|---|--------|
| 1201 – 1800 | 600 | 1 | E | 255281 |
| 1801 – 2000 | 200 KU | – | – | 308267 |
| | 600 | 1 | E | 255281 |
| 2001 – 2200 | 400 KU | – | – | 297858 |
| | 600 | 1 | E | 255281 |
| 2201 – 2400 | 200 KU | 1 | E | 450821 |
| | 400 KU | – | – | 297858 |
| | 600 | 1 | E | 255281 |
| 2401 – 2500 | 200 KU | – | – | 308267 |
| | 600 KU | 1 | E | 255282 |
| | 200 KU | – | – | 308267 |
| | 600 | 1 | E | 255281 |

[8] Roller track

| | | | Nº |
|------|-------|----------------|--------|
| 5800 | R01.1 | Natural silver | 897738 |

[9] Roller unit

| | | Nº |
|----|-------|--------|
| 41 | Left | 821686 |
| | Right | 823733 |

| < 1060 | 2 |
|--------|---|
| ≥ 1060 | 3 |

[10] Control unit, on the mullion side and in

the centre → *from page 158*

Alternatively (on the mullion side):

Control unit set with Soft function (incl. activator) → from page 158  1

| | | |
|---|---|--------|
|  |  | Nº |
| 41 | Left | 821685 |
| | Right | 823730 |

[*] Control unit set with Soft function, on the locking side → from page 158  1
Alternatively:
[10] Control unit

Contents:

| [*] |  | # |
|------|---|---|
| [29] | Activator | 1 |
| [30] | Control unit with Soft function | 1 |

[11] Centre closer

| | | |
|---|---|--------|
|  |  | Nº |
| 41 | Left | 821687 |
| | Right | 823736 |



| | |
|---|---|
|  |  |
| ≤ 1200 | 2 |
| 1201 – 2400 | 3 |
| > 2400 | 4 |

[12] MUL locking cam



| | |
|---|--------|
|  | Nº |
| 38.4 | 809614 |

| | |
|---|---|
|  |  |
| ≤ 1200 | 2 |
| 1201 – 2400 | 3 |
| > 2400 | 4 |

[14] Guide track  1



| | | | |
|---|---|---|--------|
|  |  |  | Nº |
| 5800 | R01.1 | Natural silver | 897737 |

[15] Striker to prevent incorrect operation  1

| | | |
|---|---|--------|
|  |  | Nº |
| Striker to prevent incorrect operation | Left | 897741 |
| | Right | 899721 |

[16] Parallel Sliding and Tilt&Slide handle – interior handle (200 mm handle length)  1
Sliding door handle – exterior recessed grip (43 mm distance), not sh.  1

[17] Striker

| | | |
|---|---|--------|
|  |  | Nº |
| Screw-on | Left | 897739 |

| | | |
|---|---|--------|
|  |  | Nº |
| | Right | 899669 |

| | |
|---|---|
|  |  |
| ≤ 1200 | 2 |
| 1201 – 2400 | 3 |
| > 2400 | 4 |

[18] Buffer  2

| | |
|---|--------|
|  | Nº |
| 14 | 635307 |

[20] MUL striker

| | |
|---|--------|
|  | Nº |
| Screw-on | 793493 |

| | |
|---|---|
|  |  |
| ≤ 1200 | 2 |
| 1201 – 2400 | 3 |
| > 2400 | 4 |

[21] Cover cap for MUL striker, only in combination with MUL striker, screw-on.



| | | |
|---|--|--------|
|  |  | Nº |
| R01.1 | Natural silver | 819632 |
| R05.3 | Medium bronze | 819631 |
| R06.2 | Jet black | 798979 |
| R07.2 | Traffic white | 808054 |

| | |
|---|---|
|  |  |
| ≤ 1200 | 2 |
| 1201 – 2400 | 3 |
| > 2400 | 4 |



[33] Stopper, cannot be used in conjunction with a control unit with SoftOpen and SoftStop on the mullion side.  1

| | |
|---|--------|
|  | Nº |
| Stopper | 800196 |

[23] Sash adapter profile  1

| | | | |
|---|---|---|--------|
|  |  |  | Nº |
| 5800 | R01.1 | Natural silver | 897735 |

[28] Frame adapter profile  1

| | | | |
|---|---|---|--------|
|  |  |  | Nº |
| 5800 | R01.1 | Natural silver | 897734 |









[38] Gasket pad  1



| | |
|---|---------|
|  | Nº |
| Gasket pad | 2005678 |





| Gasket for sash (not sh.)  | | | |
|---|---|---|---|
|  | Nº | | |
| Jet black | 2002067 | | |
|  |  |  | # |
| DEVENTER stop gasket | 50,000 |  | 1 |



Alternatively

| [2b] VT espagnolette, lockable (alternative to 2a)  | | | | | | | | | |
|--|---|---|---|---|---|---|---|--------|--|
|  |  |  |  |  |  |  |  | Nº | |
| 35 | 1801 – 2400 | 1890 | 200 | 1000 | 2 | V | Roto Sil | 798034 | |
| | 2401 – 2500 | 2290 | 200 | 1000 | 2 | V | Roto Sil | 798055 | |

| [37] Rubber buffer (alternative to 33)  | |
|--|--------|
|  | Nº |
| 14 | 729179 |

Optional

| [35] Brush holder | |
|---|---|
|  | Nº |
| Brush holder | 809520 |
|  |  |
| < 1060 | 2 |
| ≥ 1060 | 3 |

| [80] Tilt protection device; for application ranges SRH:SRW = > 2:1 up to max. 3:1; can only be used without control unit with Soft function.  | |
|---|--------|
|  | Nº |
| Tilt protection device | 897049 |

4.2.5.2 Diagram A – RC 2 / RC 2 N

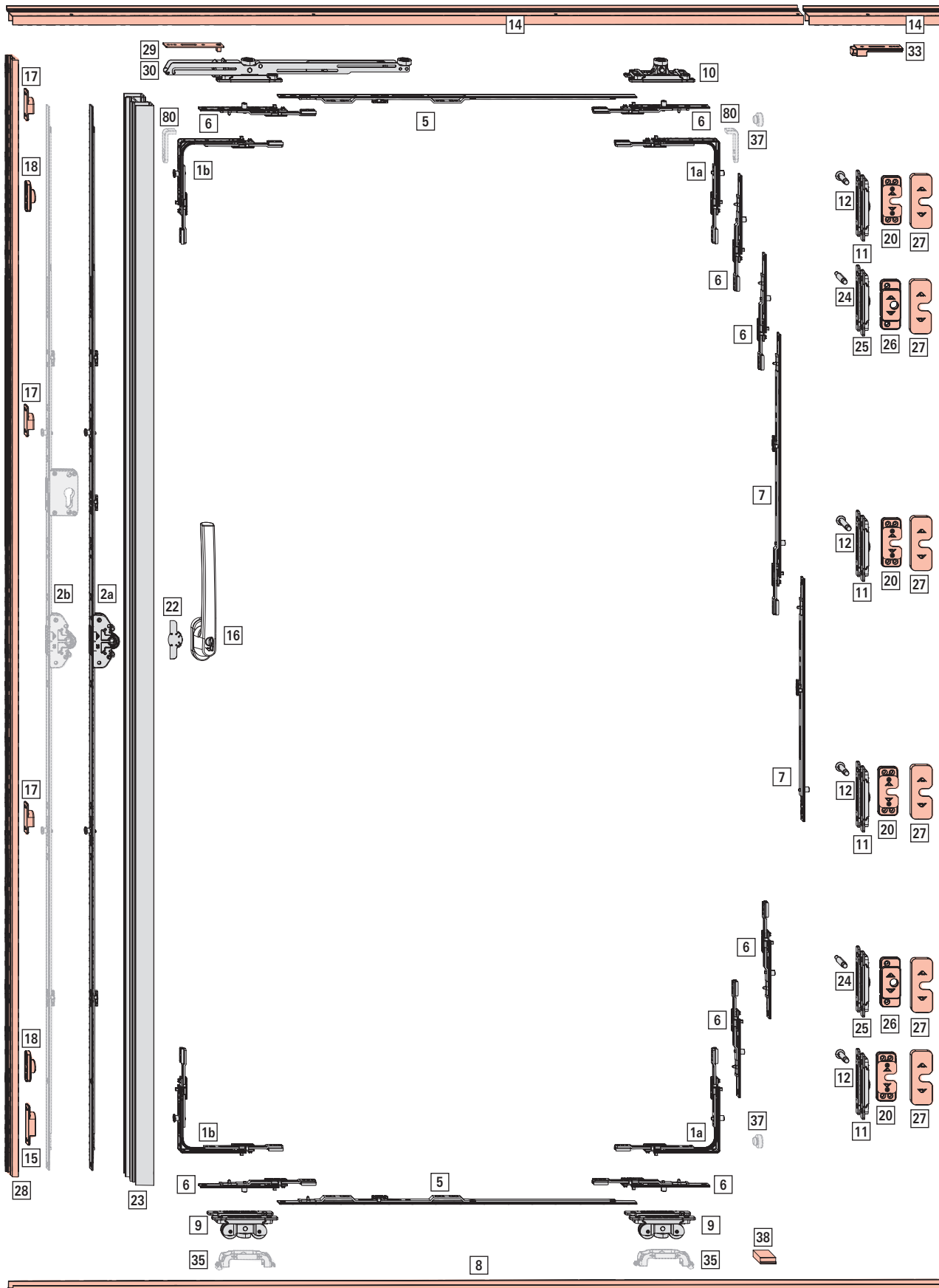



Application range

SRW: 710 – 2000 mm

SRH: 1072 – 2500 mm

S.kg: max. 250 kg

| | | | |
|--------------------------|------------|--|---|
| [1a] Corner drive | With E cam | | 2 |
| [1b] | With V cam | | 2 |

| | | Nº |
|---|---|--------|
| 1 | E | 260275 |
| 1 | V | 260272 |

[2a] VT espagnolette

| | | | | | | | Nº |
|----|-------------|------|-----|------|---|---|-----------------|
| 35 | 600 – 800 | 690 | 200 | 263 | – | – | Roto Sil 799045 |
| | 801 – 1000 | 890 | 200 | 413 | – | – | Roto Sil 798027 |
| | 1001 – 1200 | 1090 | 200 | 513 | 1 | V | Roto Sil 798028 |
| | 1201 – 1600 | 1290 | 200 | 563 | 1 | V | Roto Sil 798030 |
| | 1601 – 1800 | 1690 | 200 | 563 | 1 | V | Roto Sil 798031 |
| | 1801 – 2400 | 1890 | 200 | 1000 | 2 | V | Roto Sil 798032 |
| | 2401 – 2500 | 2290 | 200 | 1000 | 2 | V | Roto Sil 798033 |

Espagnolette extension, (SRH > 1401 mm; not sh.)

| | | | | Nº |
|-----|---|---|---|--------|
| 200 | Y | – | – | 308267 |
| 400 | Y | – | – | 297858 |

Size-specific combinations:

| | | | | Nº |
|-------------|--------|---|---|--------|
| ≤ 1400 | – | – | – | – |
| 1401 – 1600 | 200 KU | – | – | 308267 |
| 1601 – 2000 | – | – | – | – |
| 2001 – 2200 | 200 KU | – | – | 308267 |
| 2201 – 2400 | 400 KU | – | – | 297858 |
| 2401 – 2500 | 200 KU | – | – | 308267 |

Centre lock (CL)

[5] CL component, horizontal

| | | | Nº |
|------|---|---|--------|
| 200 | – | – | 308267 |
| 344 | 1 | V | 572665 |
| 480 | – | – | 245729 |
| 590 | – | – | 603442 |
| 790 | 1 | E | 603444 |
| 990 | 1 | E | 603447 |
| 1190 | 1 | E | 603462 |
| 1440 | 1 | E | 603466 |

Size-specific combinations:

| | | | | Nº |
|-------|-----|---|---|--------|
| ≤ 760 | 344 | 1 | V | 572665 |

| | | | | Nº |
|-------------|------|---|---|--------|
| 761 – 860 | 480 | – | – | 245729 |
| 861 – 1060 | 590 | – | – | 603442 |
| 1061 – 1260 | 790 | 1 | E | 603444 |
| 1261 – 1460 | 990 | 1 | E | 603447 |
| 1461 – 1660 | 1190 | 1 | E | 603462 |
| 1661 – 1910 | 1440 | 1 | E | 603466 |
| ≥ 1911 | 1440 | 1 | E | 603466 |
| | 200 | – | – | 308267 |

[6] Centre lock component 130, horizontal

| | | | | Nº |
|-----|---|---|---|--------|
| 130 | Y | 1 | E | 764350 |

[7] CL component, vertical, on the mullion

| | | | | Nº |
|-----|---|---|---|--------|
| 200 | Y | – | – | 308267 |
| | Y | 1 | E | 450821 |
| 400 | Y | – | – | 297858 |
| 600 | Y | 1 | E | 255282 |
| | N | 1 | E | 255281 |

Size-specific combinations:

| | | | | Nº |
|-------------|--------|---|---|--------|
| 1201 – 1800 | 600 | 1 | E | 255281 |
| 1801 – 2000 | 200 KU | – | – | 308267 |
| | 600 | 1 | E | 255281 |
| 2001 – 2200 | 400 KU | – | – | 297858 |
| | 600 | 1 | E | 255281 |
| 2201 – 2400 | 200 KU | 1 | E | 450821 |
| | 400 KU | – | – | 297858 |
| | 600 | 1 | E | 255281 |
| 2401 – 2500 | 200 KU | – | – | 308267 |
| | 600 KU | 1 | E | 255282 |
| | 200 KU | – | – | 308267 |
| | 600 | 1 | E | 255281 |

[8] Roller track

| | | | Nº |
|------|-------|----------------|--------|
| 5800 | R01.1 | Natural silver | 897738 |

[9] Roller unit

| | | Nº |
|----|-------|--------|
| 41 | Left | 821686 |
| | Right | 823733 |

| | Nº |
|--------|----|
| < 1060 | 2 |
| ≥ 1060 | 3 |

[10] Control unit, on the mullion side and in the centre → from page 158

Alternatively (on the mullion side):

Control unit set with Soft function (incl. activator) → from page 158 

| |  |  | Nº |
|----|---|---|--------|
| 41 | | Left | 821685 |
| | | Right | 823730 |

[*] Control unit set with Soft function, on the locking side → from page 158 

Alternatively:

[10] Control unit 

Contents:

| [*] |  | # |
|------|---|---|
| [29] | Activator | 1 |
| [30] | Control unit with Soft function | 1 |

[11] Centre closer

| |  |  | Nº |
|----|---|---|--------|
| 41 | | Left | 821687 |
| | | Right | 823736 |



| |  |  |
|-------------|---|---|
| ≤ 1072 | 2 | |
| 1073 – 1700 | 3 | |
| 1701 – 2100 | 4 | |
| > 2100 | 5 | |

[12] MUL locking cam



| |  | Nº |
|------|---|--------|
| 38.4 | | 809614 |

| |  |  |
|-------------|---|---|
| ≤ 1072 | 2 | |
| 1073 – 1700 | 3 | |
| 1701 – 2100 | 4 | |
| > 2100 | 5 | |

[14] Guide track 

| |  |  |  | Nº |
|------|---|---|---|--------|
| 5800 | R01.1 | Natural silver | | 897737 |

[15] SEC striker to prevent incorrect operation 

| |  |  | Nº |
|--|---|---|--------|
| SEC striker to prevent incorrect operation | | Left | 897742 |
| | | Right | 899722 |

[16] Parallel Sliding and Tilt&Slide handle – interior handle, lockable (200 mm handle length) 

Sliding door handle – exterior recessed grip (43 mm distance), not sh. 

[17] SEC striker

| |  |  | Nº |
|----------|---|---|--------|
| Screw-on | | Left | 897740 |
| | | Right | 899720 |

| |  |  |
|-------------|---|---|
| ≤ 1072 | 2 | |
| 1073 – 1700 | 3 | |
| 1701 – 2100 | 4 | |
| > 2100 | 5 | |

[18] Buffer 

| |  | Nº |
|----|---|--------|
| 14 | | 635307 |

[20] SEC MUL striker

| |  | Nº |
|------|---|--------|
| 31.6 | | 833688 |

| |  |  |
|-------------|--|--|
| ≤ 1072 | 2 | |
| 1073 – 1700 | 3 | |
| 1701 – 2100 | 4 | |
| > 2100 | 5 | |

[22] Drilling protection 

| |  | Nº |
|---------------------|---|--------|
| Drilling protection | | 770965 |

[24] Pin for anti-pushback function 

| |  | Nº |
|----|---|--------|
| 38 | | 820048 |

[25] Centre closer for anti-pushback function 

| |  |  | Nº |
|----|---|---|--------|
| 41 | | Left | 821687 |
| | | Right | 823736 |

INFO

DIN L: order right components.

DIN R: order left components.

[26] Striker for anti-pushback function 

| |  | Nº |
|------------------------------------|---|--------|
| Striker for anti-pushback function | | 810279 |





[27] Cover cap for SEC MUL striker / striker for anti-pushback function

| | | |
|---|---|--------|
|  |  | Nº |
| R01.1 | Natural silver | 828482 |
| R05.3 | Medium bronze | 828483 |
| R06.2 | Jet black | 809717 |
| R07.2 | Traffic white | 819351 |
|  |  | |
| ≤ 1072 | 2 | |
| 1073 – 1700 | 3 | |
| 1701 – 2100 | 4 | |
| > 2100 | 5 | |



[33] Stopper, cannot be used in conjunction with a control unit with SoftOpen and SoftStop on the mullion side. 

| | |
|---|--------|
|  | Nº |
| Stopper | 800196 |

[23] Sash adapter profile 

| | | | |
|---|---|---|--------|
|  |  |  | Nº |
| 5800 | R01.1 | Natural silver | 897735 |

[28] Frame adapter profile 





| | | | |
|---|---|---|--------|
|  |  |  | Nº |
| 5800 | R01.1 | Natural silver | 897734 |

[38] Gasket pad 

| | |
|---|---------|
|  | Nº |
| Gasket pad | 2005678 |









Gasket for sash (not sh.) 

| | |
|---|---------|
|  | Nº |
| Jet black | 2002067 |

| | | | |
|---|---|---|---|
|  |  |  | # |
| DEVENTER stop gasket | 50,000 |  | 1 |

Alternatively

[2b] VT espagnolette, lockable (alternative to 2a) 



| | | | | | | | | |
|---|---|---|---|---|---|---|---|--------|
|  |  |  |  |  |  |  |  | Nº |
| 35 | 1801 – 2400 | 1890 | 200 | 1000 | 2 | V | Roto Sil | 798034 |
| | 2401 – 2500 | 2290 | 200 | 1000 | 2 | V | Roto Sil | 798055 |

[37] Rubber buffer (alternative to 33) 

| | |
|---|--------|
|  | Nº |
| 14 | 729179 |

Optional





[35] Brush holder

| | |
|---|---|
|  | Nº |
| Brush holder | 809520 |
|  |  |
| < 1060 | 2 |
| ≥ 1060 | 3 |

[80] Tilt protection device; for application ranges SRH:SRW = > 2:1 up to max. 3:1; can only be used without control unit with Soft function. 

| | |
|---|--------|
|  | Nº |
| Tilt protection device | 897049 |

SKG info clip**, not sh. 

| | | | | |
|---|---|---|---|--------|
|  |  |  |  | Nº |
| SKG** info clip | For clipping onto the gearbox | R07.2 | Traffic white | 331459 |

4.2.5.3 Diagram C

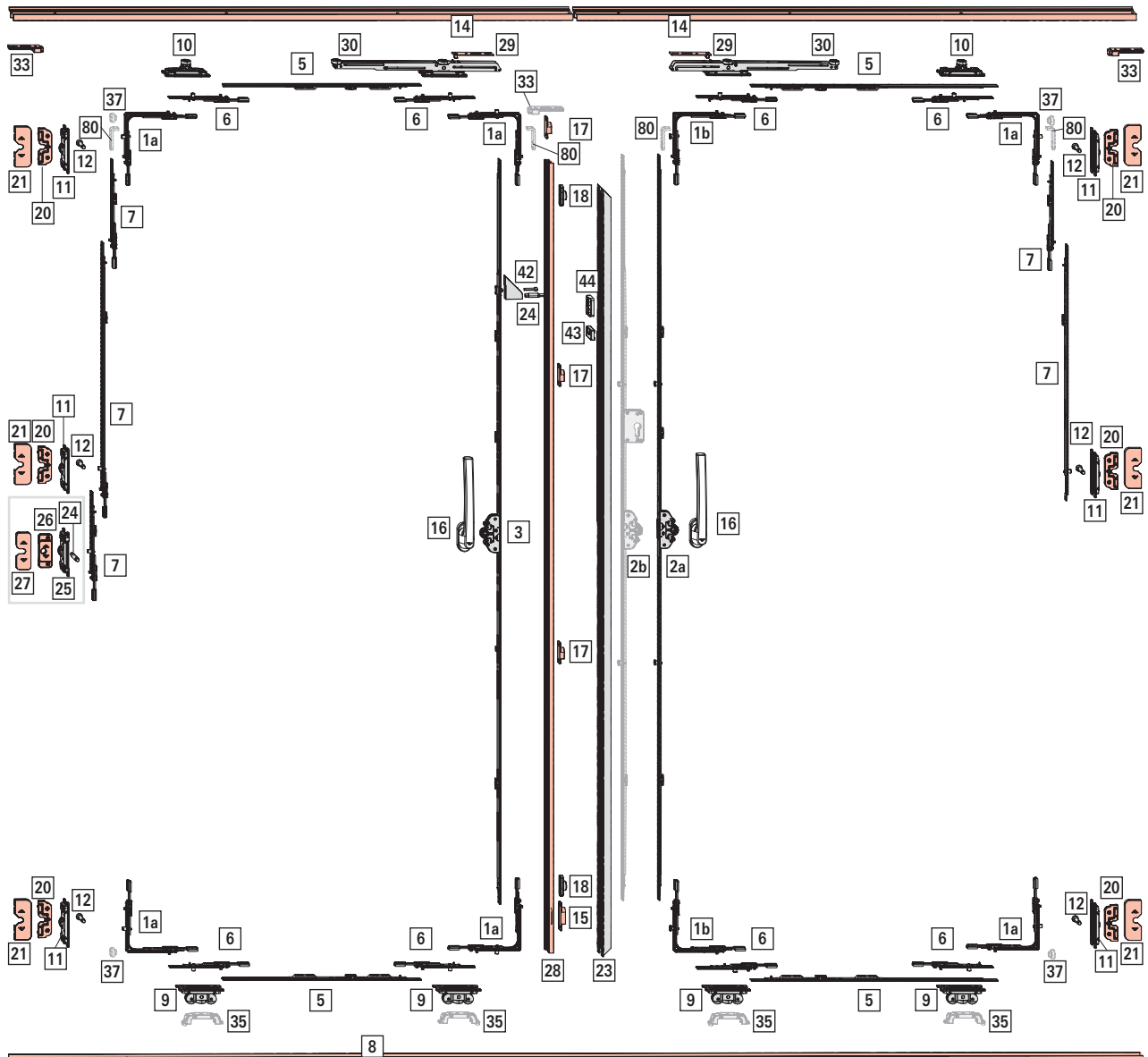



Application range

SRW: 710 – 1500 mm

SRH: 600 – 2500 mm

S.kg: max. 250 kg

| | | | |
|--------------------------|---|----------------|---|
| [1a] Corner drive | | With E cam | 6 |
| [1b] | | With V cam | 2 |
| | | N ^o | |
| 1 | E | 260275 | |
| 1 | V | 260272 | |

| | | |
|-----------------------------|--|---|
| [2a] VT espagnolette | | 1 |
| BS 25 for profile 9772 | | |
| BS 35 for profile 9771 | | |

| | | | | | | | | | N ^o |
|----|-------------|------|-----|------|---|---|----------|--------|----------------|
| 35 | 600 – 800 | 690 | 200 | 263 | – | – | Roto Sil | 799045 | |
| | 801 – 1000 | 890 | 200 | 413 | – | – | Roto Sil | 798027 | |
| | 1001 – 1200 | 1090 | 200 | 513 | 1 | V | Roto Sil | 798028 | |
| | 1201 – 1600 | 1290 | 200 | 563 | 1 | V | Roto Sil | 798030 | |
| | 1601 – 1800 | 1690 | 200 | 563 | 1 | V | Roto Sil | 798031 | |
| | 1801 – 2400 | 1890 | 200 | 1000 | 2 | V | Roto Sil | 798032 | |
| | 2401 – 2500 | 2290 | 200 | 1000 | 2 | V | Roto Sil | 798033 | |

| [3] VT espagnolette, second opening sash | | 1 | | | | | | | |
|---|-------------|------|-----|------|---|---|----------|--------|----------------|
| | | | | | | | | | N ^o |
| 40 | 600 – 800 | 690 | 200 | 263 | – | – | Roto Sil | 792143 | |
| | 801 – 1000 | 890 | 200 | 413 | – | – | Roto Sil | 792144 | |
| | 1001 – 1200 | 1090 | 200 | 513 | – | – | Roto Sil | 809645 | |
| | 1201 – 1600 | 1290 | 200 | 563 | – | – | Roto Sil | 809646 | |
| | 1601 – 1800 | 1690 | 200 | 563 | – | – | Roto Sil | 809648 | |
| | 1801 – 2400 | 1890 | 200 | 1000 | – | – | Roto Sil | 809649 | |
| | 2401 – 2500 | 2290 | 200 | 1000 | – | – | Roto Sil | 809651 | |

| Espagnolette extension, (SRH > 1401 mm; not sh.) | | | | |
|--|---|---|---|----------------|
| | | | | N ^o |
| 200 | Y | – | – | 308267 |
| 400 | Y | – | – | 297858 |

Size-specific combinations:

| | | | | N ^o |
|-------------|--------|---|---|----------------|
| ≤ 1400 | – | – | – | – |
| 1401 – 1600 | 200 KU | – | – | 308267 |
| 1601 – 2000 | – | – | – | – |
| 2001 – 2200 | 200 KU | – | – | 308267 |
| 2201 – 2400 | 400 KU | – | – | 297858 |
| 2401 – 2500 | 200 KU | – | – | 308267 |

Centre lock (CL)

| [5] CL component, horizontal | | | |
|-------------------------------------|---|---|----------------|
| | | | N ^o |
| 200 | – | – | 308267 |
| 344 | 1 | V | 572665 |
| 480 | – | – | 245729 |
| 590 | – | – | 603442 |
| 790 | 1 | E | 603444 |
| 990 | 1 | E | 603447 |
| 1190 | 1 | E | 603462 |
| 1440 | 1 | E | 603466 |

Size-specific combinations:

| First or second opening sash | | | | |
|-------------------------------------|------|---|---|----------------|
| | | | | N ^o |
| ≤ 760 | 344 | 1 | V | 572665 |
| 761 – 860 | 480 | – | – | 245729 |
| 861 – 1060 | 590 | – | – | 603442 |
| 1061 – 1260 | 790 | 1 | E | 603444 |
| 1261 – 1460 | 990 | 1 | E | 603447 |
| 1461 – 1660 | 1190 | 1 | E | 603462 |
| 1661 – 1910 | 1440 | 1 | E | 603466 |
| ≥ 1911 | 1440 | 1 | E | 603466 |
| | 200 | – | – | 308267 |





| [6] Centre lock component 130, horizontal and vertical | | | | | 8 |
|---|---|---|---|----------------|---|
| | | | | N ^o | |
| 130 | Y | 1 | E | 764350 | |

| [7] CL component, vertical, on the mullion | | | | |
|---|---|---|---|----------------|
| | | | | N ^o |
| 200 | Y | – | – | 308267 |
| | Y | 1 | E | 450821 |
| 400 | Y | – | – | 297858 |
| 600 | Y | 1 | E | 255282 |
| | N | 1 | E | 255281 |



Size-specific combinations:

| First opening sash: | | | | |
|----------------------------|--------|---|---|----------------|
| | | | | N ^o |
| 1201 – 1800 | 600 | 1 | E | 255281 |
| 1801 – 2000 | 200 KU | – | – | 308267 |
| | 600 | 1 | E | 255281 |
| 2001 – 2200 | 400 KU | – | – | 297858 |
| | 600 | 1 | E | 255281 |
| 2201 – 2400 | 200 KU | 1 | E | 450821 |
| | 400 KU | – | – | 297858 |
| | 600 | 1 | E | 255281 |
| 2401 – 2500 | 200 KU | – | – | 308267 |
| | 600 KU | 1 | E | 255282 |
| | 200 KU | – | – | 308267 |
| | 600 | 1 | E | 255281 |



Second opening sash:

|  |  |  |  | Nº |
|---|---|---|---|--------|
| 600 – 1200 | 200 KU | 1 | E | 450821 |
| 1201 – 1800 | 600 KU | 1 | E | 255282 |
| | 200 KU | 1 | E | 450821 |
| 1801 – 2000 | 200 KU | – | – | 308267 |
| | 600 KU | 1 | E | 255282 |
| | 200 KU | 1 | E | 450821 |
| 2001 – 2200 | 400 KU | – | – | 297858 |
| | 600 KU | 1 | E | 255282 |
| | 200 KU | 1 | E | 450821 |
| 2201 – 2400 | 200 KU | 1 | E | 450821 |
| | 400 KU | – | – | 297858 |
| | 600 KU | 1 | E | 255282 |
| | 200 KU | 1 | E | 450821 |
| 2401 – 2500 | 200 KU | – | – | 308267 |
| | 600 KU | 1 | E | 255282 |
| | 200 KU | – | – | 308267 |
| | 600 KU | 1 | E | 255282 |
| | 200 KU | 1 | E | 450821 |

| [8] Roller track | | | |  |
|---|---|---|--------|---|
|  |  |  | Nº | |
| 5800 | R01.1 | Natural silver | 897738 | 1 |

| [9] Roller unit | | | |
|---|---|--------|--|
|  |  | Nº | |
| 41 | Left | 821686 | |
| | Right | 823733 | |

|  |  |
|---|---|
| < 1060 | 4 |
| ≥ 1060 | 6 |



[10] Control unit, on the mullion side and in the centre  2-4
 Alternatively (on the mullion side):
 Control unit set with Soft function → *from*  2 *page 158*
 Activator for Soft function can be used with an asymmetrical screw fixing → *from*  2 *page 159*

|  |  | Nº |
|---|---|--------|
| 41 | Left | 821685 |
| | Right | 823730 |

[*] Control unit set with Soft function, on the locking side → *from*  2 *page 158*
 Alternatively:

[10] Control unit

Contents:

|  |  | # |
|---|---|---|
| [29] | Activator | 1 |
| [30] | Control unit with Soft function | 1 |



[11] Centre closer

|  |  | Nº |
|---|---|--------|
| 41 | Left | 821687 |
| | Right | 823736 |

|  |  |
|---|---|
| ≤ 1200 | 4 |
| 1201 – 2400 | 6 |
| > 2400 | 8 |

[12] MUL locking cam

|  | Nº |
|---|--------|
| 38.4 | 809614 |



|  |  |
|---|---|
| ≤ 1200 | 4 |
| 1201 – 2400 | 6 |
| > 2400 | 8 |

[14] Guide track

|  |  |  | Nº |
|---|---|---|--------|
| 5800 | R01.1 | Natural silver | 897737 |

[15] Striker to prevent incorrect operation

|  | Nº |
|---|--------|
| Striker to prevent incorrect operation | 822789 |

[16] Parallel Sliding and Tilt&Slide handle – interior handle (200 mm handle length)  2
Sliding door handle – exterior recessed grip (43 mm distance), not sh.  2

[17] Striker

|  | Nº |
|---|--------|
| Screw-on | 744579 |

|  |  |
|---|---|
| ≤ 1200 | 2 |
| 1201 – 2400 | 3 |
| > 2400 | 4 |

[18] Buffer

|  | Nº |
|---|--------|
| 14 | 635307 |



[20] MUL striker

| | |
|-------------|--------|
| | Nº |
| Screw-on | 793493 |
| | |
| ≤ 1200 | 4 |
| 1201 – 2400 | 6 |
| > 2400 | 8 |

[21] Cover cap for MUL striker, only in combination with MUL striker, screw-on.

| | | |
|-------------|----------------|--------|
| | | Nº |
| R01.1 | Natural silver | 819632 |
| R05.3 | Medium bronze | 819631 |
| R06.2 | Jet black | 798979 |
| R07.2 | Traffic white | 808054 |
| | | |
| ≤ 1200 | 4 | |
| 1201 – 2400 | 6 | |
| > 2400 | 8 | |

[*] Operating sequence control set 1
SRH ≥ 1200 mm, profile-related

| | |
|--------------------|---------|
| | Nº |
| For widths > 40 mm | 2029689 |

| | |
|--|----------|
| [*] | # |
| [42] Trapezoid with M5 x 20 cylinder screw | 1 |
| [43] Anti-lifting device | 1 |
| [44] Striker with buffer | 1 |

[24] Pin for anti-pushback function 2

| | |
|----|--------|
| | Nº |
| 38 | 820048 |

[25] Centre closer for anti-pushback function 1

| | | |
|----|-------|--------|
| | | Nº |
| 41 | Left | 821687 |
| | Right | 823736 |



INFO

DIN L: order right components.

DIN R: order left components.

[26] Striker for anti-pushback function 1

| | |
|------------------------------------|--------|
| | Nº |
| Striker for anti-pushback function | 810279 |

[27] Cover cap for striker for anti-pushback function 1

| | | |
|-------|----------------|--------|
| | | Nº |
| R01.1 | Natural silver | 828482 |

| | | |
|-------|---------------|--------|
| | | Nº |
| R05.3 | Medium bronze | 828483 |
| R06.2 | Jet black | 809717 |
| R07.2 | Traffic white | 819351 |

[33] Stopper, cannot be used in conjunction with a control unit with SoftOpen and SoftStop on the mullion side. 1

| | |
|---------|--------|
| | Nº |
| Stopper | 800196 |

[23] Sash adapter profile 1

| | | | |
|------|-------|----------------|--------|
| | | | Nº |
| 5800 | R01.1 | Natural silver | 897735 |

[28] Frame adapter profile 1

| | | | |
|------|-------|----------------|--------|
| | | | Nº |
| 5800 | R01.1 | Natural silver | 897734 |

Alternatively

[2b] VT espagnolette, lockable (alternative to 2a) 1

BS 25 for profile 9772

BS 35 for profile 9771

| | | | | | | | | |
|----|-------------|------|-----|------|---|---|----------|--------|
| | | | | | | | | Nº |
| 25 | 1801 – 2400 | 1890 | 200 | 1000 | 2 | V | Roto Sil | 798285 |
| | 2401 – 2500 | 2290 | 200 | 1000 | 2 | V | Roto Sil | 798286 |
| 35 | 1801 – 2400 | 1890 | 200 | 1000 | 2 | V | Roto Sil | 798034 |
| | 2401 – 2500 | 2290 | 200 | 1000 | 2 | V | Roto Sil | 798055 |

[37] Rubber buffer (alternative to 33) 4

| | |
|----|--------|
| | Nº |
| 14 | 729179 |

Optional

[35] Brush holder

| | |
|--------------|--------|
| | Nº |
| Brush holder | 809520 |

| | |
|--------|---|
| | |
| < 1060 | 4 |
| ≥ 1060 | 6 |

[80] **Tilt protection device**; for application ranges SRH:SRW = > 2:1 up to max. 3:1; can only be used without control unit with Soft function.  4



Nº

Tilt protection device

897049





Application range

SRW: 710 – 2000 mm

SRH: 600 – 2500 mm

S.kg: max. 250 kg

| | | | |
|--------------------------|------------|--|---|
| [1a] Corner drive | With E cam | | 2 |
| [1b] | With V cam | | 2 |

| | | Nº |
|---|---|--------|
| 1 | E | 260275 |
| 1 | V | 260272 |

| | | |
|-----------------------------|--|---|
| [2a] VT espagnolette | | 1 |
| BS 25 for profile 9772 | | |
| BS 35 for profile 9771 | | |

| | | | | | | | | Nº |
|-------------|-------------|------|------|------|---|---|--------|--------|
| 25 | 600 – 800 | 690 | 200 | 263 | – | – | – | 793942 |
| | 801 – 1000 | 890 | 200 | 413 | – | – | – | 793943 |
| | 1001 – 1200 | 1090 | 200 | 513 | 1 | V | – | 793944 |
| | 1201 – 1600 | 1290 | 200 | 563 | 1 | V | – | 793975 |
| | 1601 – 1800 | 1690 | 200 | 563 | 1 | V | – | 793977 |
| 35 | 1801 – 2400 | 1890 | 200 | 1000 | 2 | V | – | 793978 |
| | 2401 – 2500 | 2290 | 200 | 1000 | 2 | V | – | 793980 |
| | 600 – 800 | 690 | 200 | 263 | – | – | – | 799045 |
| | 801 – 1000 | 890 | 200 | 413 | – | – | – | 798027 |
| | 1001 – 1200 | 1090 | 200 | 513 | 1 | V | – | 798028 |
| 1201 – 1600 | 1290 | 200 | 563 | 1 | V | – | 798030 | |
| 1601 – 1800 | 1690 | 200 | 563 | 1 | V | – | 798031 | |
| 1801 – 2400 | 1890 | 200 | 1000 | 2 | V | – | 798032 | |
| 2401 – 2500 | 2290 | 200 | 1000 | 2 | V | – | 798033 | |

Espagnolette extension, (SRH > 1401 mm; not sh.)

| | | | | Nº |
|-----|---|---|---|--------|
| 200 | Y | – | – | 308267 |
| 400 | Y | – | – | 297858 |

Size-specific combinations:

| | | | | Nº |
|-------------|--------|---|---|--------|
| ≤ 1400 | – | – | – | – |
| 1401 – 1600 | 200 KU | – | – | 308267 |
| 1601 – 2000 | – | – | – | – |
| 2001 – 2200 | 200 KU | – | – | 308267 |
| 2201 – 2400 | 400 KU | – | – | 297858 |
| 2401 – 2500 | 200 KU | – | – | 308267 |

Centre lock (CL)

| [5] CL component, horizontal | | 1 | |
|-------------------------------------|---|---|--------|
| | | | Nº |
| 200 | – | – | 308267 |
| 344 | 1 | V | 572665 |
| 480 | – | – | 245729 |

| | | | Nº |
|------|---|---|--------|
| 590 | – | – | 603442 |
| 790 | 1 | E | 603444 |
| 990 | 1 | E | 603447 |
| 1190 | 1 | E | 603462 |
| 1440 | 1 | E | 603466 |

Size-specific combinations:

| | | | | Nº |
|-------------|------|---|---|--------|
| ≤ 760 | 344 | 1 | V | 572665 |
| 761 – 860 | 480 | – | – | 245729 |
| 861 – 1060 | 590 | – | – | 603442 |
| 1061 – 1260 | 790 | 1 | E | 603444 |
| 1261 – 1460 | 990 | 1 | E | 603447 |
| 1461 – 1660 | 1190 | 1 | E | 603462 |
| 1661 – 1910 | 1440 | 1 | E | 603466 |
| ≥ 1911 | 1440 | 1 | E | 603466 |
| | 200 | – | – | 308267 |

[6] Centre lock component 130, horizontal

| | 4 | | | |
|-----|---|---|---|--------|
| | | | | Nº |
| 130 | Y | 1 | E | 764350 |

[7] CL component, vertical, on the mullion

| | | | | Nº |
|-----|---|---|---|--------|
| 200 | Y | – | – | 308267 |
| | Y | 1 | E | 450821 |
| 400 | Y | – | – | 297858 |
| 600 | Y | 1 | E | 255282 |
| | N | 1 | E | 255281 |

Size-specific combinations:

| | | | | Nº |
|-------------|--------|---|---|--------|
| 1201 – 1800 | 600 | 1 | E | 255281 |
| 1801 – 2000 | 200 KU | – | – | 308267 |
| | 600 | 1 | E | 255281 |
| 2001 – 2200 | 400 KU | – | – | 297858 |
| | 600 | 1 | E | 255281 |
| 2201 – 2400 | 200 KU | 1 | E | 450821 |
| | 400 KU | – | – | 297858 |
| 2401 – 2500 | 600 | 1 | E | 255281 |
| | 200 KU | – | – | 308267 |
| | 600 KU | 1 | E | 255282 |
| | 200 KU | – | – | 308267 |
| | 600 | 1 | E | 255281 |

[8] Roller track

| | 1 | | |
|------|----------------|-------|---------|
| | | | Nº |
| 3200 | Natural silver | R01.1 | 2006845 |
| 6400 | Natural silver | R01.1 | 2006884 |

[9] Roller unit

| |  |  | Nº |
|---|---|---|--------|
| 41 | | Left | 821686 |
| | | Right | 823733 |
|  | | | |
| < 1060 | | | 2 |
| ≥ 1060 | | | 3 |

[10] Control unit, on the mullion side and in the centre → from page 158  1-2

Alternatively (on the mullion side):
Control unit set with Soft function (incl. activator) → from page 158  1

| |  |  | Nº |
|----|---|---|--------|
| 41 | | Left | 821685 |
| | | Right | 823730 |



[*] Control unit set with Soft function, on the locking side → from page 158  1

Alternatively:
[10] Control unit 

Contents:

| [*] |  | # |
|------|---|---|
| [29] | Activator | 1 |
| [30] | Control unit with Soft function | 1 |



[11] Centre closer

| |  |  | Nº |
|---|---|---|--------|
| 41 | | Left | 821687 |
| | | Right | 823736 |
|  | | | |
| ≤ 1200 | | | 2 |
| 1201 – 2400 | | | 3 |
| > 2400 | | | 4 |

[12] MUL locking cam

| |  | Nº |
|---|---|---------|
| 39 | | 2006890 |
|  | | |
| ≤ 1200 | | 2 |
| 1201 – 2400 | | 3 |
| > 2400 | | 4 |

[14] Guide track  1

| |  |  |  | Nº |
|------|---|---|---|---------|
| 3200 | | Natural silver | R01.1 | 2006846 |
| 6400 | | Natural silver | R01.1 | 2006885 |

[15] Striker to prevent incorrect operation  1

| |  | Nº |
|--|---|--------|
| Striker to prevent incorrect operation | | 822789 |

[16] Parallel Sliding and Tilt&Slide handle – interior handle (200 mm handle length)  1

Sliding door handle – exterior recessed grip (43 mm distance), not sh.  1

[17] Striker

| |  | Nº |
|---|---|--------|
| Screw-on | | 744579 |
|  | | |
| ≤ 1200 | | 2 |
| 1201 – 2400 | | 3 |
| > 2400 | | 4 |

[18] Buffer  2

| |  | Nº |
|----|---|--------|
| 14 | | 635307 |

[20] MUL striker

| |  | Nº |
|---|---|--------|
| Screw-on | | 793493 |
|  | | |
| ≤ 1200 | | 2 |
| 1201 – 2400 | | 3 |
| > 2400 | | 4 |

[21] Cover cap for MUL striker, only in combination with MUL striker, screw-on.



| |  |  | Nº |
|-------|---|--|--------|
| R01.1 | | Natural silver | 819632 |
| R05.3 | | Medium bronze | 819631 |
| R06.2 | | Jet black | 798979 |
| R07.2 | | Traffic white | 808054 |

| |  | Nº |
|-------------|---|----|
| ≤ 1200 | | 2 |
| 1201 – 2400 | | 3 |
| > 2400 | | 4 |

[33] Stopper, cannot be used in conjunction with a control unit with SoftOpen and SoftStop on the mullion side.  1



| |  | Nº |
|---------|---|--------|
| Stopper | | 800196 |

[23] Sash adapter profile  1

| |  |  |  | Nº |
|------|---|---|---|---------|
| 3200 | | Natural silver | R01.1 | 2006848 |
| 6400 | | Natural silver | R01.1 | 2006887 |



[28] Frame adapter profile  1









|  |  |  | Nº |
|---|---|---|---------|
| 3200 | Natural silver | R01.1 | 2006847 |
| 6400 | Natural silver | R01.1 | 2006886 |

Alternatively

[2b] VT espagnolette, lockable (alternative to 2a)  1

BS 25 for profile 9772

BS 35 for profile 9771

|  |  |  |  |  |  |  |  |  | Nº |
|---|---|---|---|---|---|---|---|---|----|
| 25 | 1801 – 2400 | 1890 | 200 | 1000 | 2 | V | Roto Sil | 798285 | |
| | 2401 – 2500 | 2290 | 200 | 1000 | 2 | V | Roto Sil | 798286 | |
| 35 | 1801 – 2400 | 1890 | 200 | 1000 | 2 | V | Roto Sil | 798034 | |
| | 2401 – 2500 | 2290 | 200 | 1000 | 2 | V | Roto Sil | 798055 | |

[37] Rubber buffer (alternative to 33)  2

|  | Nº |
|---|--------|
| 14 | 729179 |

Optional

[35] Brush holder

|  | Nº |
|---|--------|
| Brush holder | 809520 |

|  |  |
|---|---|
| < 1060 | 2 |
| ≥ 1060 | 3 |

[80] Tilt protection device; for application ranges SRH:SRW = > 2:1 up to max. 3:1; can only be used without control unit with Soft function.  2

|  | Nº |
|---|--------|
| Tilt protection device | 897049 |



Application range

SRW: 710 – 2000 mm

SRH: 1072 – 2500 mm

S.kg: max. 250 kg

| | | | |
|--------------------------|------------|--|---|
| [1a] Corner drive | With E cam | | 2 |
| [1b] | With V cam | | 2 |

| | | Nº |
|---|---|--------|
| 1 | E | 260275 |
| 1 | V | 260272 |

| | | |
|-----------------------------|--|---|
| [2a] VT espagnolette | | 1 |
| BS 25 for profile 9772 | | |
| BS 35 for profile 9771 | | |

| | | | | | | | | Nº |
|-------------|-------------|------|------|------|---|---|--------|--------|
| 25 | 600 – 800 | 690 | 200 | 263 | – | – | – | 793942 |
| | 801 – 1000 | 890 | 200 | 413 | – | – | – | 793943 |
| | 1001 – 1200 | 1090 | 200 | 513 | 1 | V | – | 793944 |
| | 1201 – 1600 | 1290 | 200 | 563 | 1 | V | – | 793975 |
| | 1601 – 1800 | 1690 | 200 | 563 | 1 | V | – | 793977 |
| 35 | 1801 – 2400 | 1890 | 200 | 1000 | 2 | V | – | 793978 |
| | 2401 – 2500 | 2290 | 200 | 1000 | 2 | V | – | 793980 |
| | 600 – 800 | 690 | 200 | 263 | – | – | – | 799045 |
| | 801 – 1000 | 890 | 200 | 413 | – | – | – | 798027 |
| | 1001 – 1200 | 1090 | 200 | 513 | 1 | V | – | 798028 |
| 1201 – 1600 | 1290 | 200 | 563 | 1 | V | – | 798030 | |
| 1601 – 1800 | 1690 | 200 | 563 | 1 | V | – | 798031 | |
| 1801 – 2400 | 1890 | 200 | 1000 | 2 | V | – | 798032 | |
| 2401 – 2500 | 2290 | 200 | 1000 | 2 | V | – | 798033 | |

Espagnolette extension, (SRH > 1401 mm; not sh.)

| | | | | Nº |
|-----|---|---|---|--------|
| 200 | Y | – | – | 308267 |
| 400 | Y | – | – | 297858 |

Size-specific combinations:

| | | | | Nº |
|-------------|--------|---|---|--------|
| ≤ 1400 | – | – | – | – |
| 1401 – 1600 | 200 KU | – | – | 308267 |
| 1601 – 2000 | – | – | – | – |
| 2001 – 2200 | 200 KU | – | – | 308267 |
| 2201 – 2400 | 400 KU | – | – | 297858 |
| 2401 – 2500 | 200 KU | – | – | 308267 |

Centre lock (CL)

| [5] CL component, horizontal | | 1 | |
|-------------------------------------|---|---|--------|
| | | | Nº |
| 200 | – | – | 308267 |
| 344 | 1 | V | 572665 |
| 480 | – | – | 245729 |

| | | | Nº |
|------|---|---|--------|
| 590 | – | – | 603442 |
| 790 | 1 | E | 603444 |
| 990 | 1 | E | 603447 |
| 1190 | 1 | E | 603462 |
| 1440 | 1 | E | 603466 |

Size-specific combinations:

| | | | | Nº |
|-------------|------|---|---|--------|
| ≤ 760 | 344 | 1 | V | 572665 |
| 761 – 860 | 480 | – | – | 245729 |
| 861 – 1060 | 590 | – | – | 603442 |
| 1061 – 1260 | 790 | 1 | E | 603444 |
| 1261 – 1460 | 990 | 1 | E | 603447 |
| 1461 – 1660 | 1190 | 1 | E | 603462 |
| 1661 – 1910 | 1440 | 1 | E | 603466 |
| ≥ 1911 | 1440 | 1 | E | 603466 |
| | 200 | – | – | 308267 |

| [6] Centre lock component 130, horizontal | | 4 | | |
|--|---|---|---|--------|
| | | | | Nº |
| 130 | Y | 1 | E | 764350 |

| [7] CL component, vertical, on the mullion | | 1 | | |
|---|---|---|---|--------|
| | | | | Nº |
| 200 | Y | – | – | 308267 |
| | Y | 1 | E | 450821 |
| 400 | Y | – | – | 297858 |
| 600 | Y | 1 | E | 255282 |
| | N | 1 | E | 255281 |

Size-specific combinations:

| | | | | Nº |
|-------------|--------|---|---|--------|
| 1201 – 1800 | 600 | 1 | E | 255281 |
| 1801 – 2000 | 200 KU | – | – | 308267 |
| | 600 | 1 | E | 255281 |
| 2001 – 2200 | 400 KU | – | – | 297858 |
| | 600 | 1 | E | 255281 |
| 2201 – 2400 | 200 KU | 1 | E | 450821 |
| | 400 KU | – | – | 297858 |
| 2401 – 2500 | 600 | 1 | E | 255281 |
| | 200 KU | – | – | 308267 |
| | 600 KU | 1 | E | 255282 |
| | 200 KU | – | – | 308267 |
| | 600 | 1 | E | 255281 |

| [8] Roller track | | 1 | |
|-------------------------|----------------|-------|---------|
| | | | Nº |
| 3200 | Natural silver | R01.1 | 2006845 |
| 6400 | Natural silver | R01.1 | 2006884 |

[9] Roller unit

| |  |  | Nº |
|--------|---|---|---|
| 41 | | Left | 821686 |
| | | Right | 823733 |
| | | | |
| |  | |  |
| < 1060 | | | 2 |
| ≥ 1060 | | | 3 |

[10] Control unit, on the mullion side and in the centre → from page 158  1-2
Alternatively (on the mullion side):
Control unit set with Soft function (incl. activator) → from page 158  1



| |  |  | Nº |
|----|---|---|--------|
| 41 | | Left | 821685 |
| | | Right | 823730 |

[*] Control unit set with Soft function, on the locking side → from page 158  1
Alternatively:
[10] Control unit



Contents:

| [*] |  | # |
|------|---|---|
| [29] | Activator | 1 |
| [30] | Control unit with Soft function | 1 |



[11] Centre closer

| |  |  | Nº |
|-------------|---|---|---|
| 41 | | Left | 821687 |
| | | Right | 823736 |
| | | | |
| |  | |  |
| ≤ 1072 | | | 2 |
| 1073 – 1700 | | | 3 |
| 1701 – 2100 | | | 4 |
| > 2100 | | | 5 |

[12] MUL locking cam



| |  | Nº |
|-------------|---|---|
| 39 | | 2006890 |
| | | |
| |  |  |
| ≤ 1072 | | 2 |
| 1073 – 1700 | | 3 |
| 1701 – 2100 | | 4 |
| > 2100 | | 5 |

[14] Guide track  1

| |  |  |  | Nº |
|------|---|---|---|--------|
| 5800 | | R01.1 | Natural silver | 897737 |

[15] SEC striker to prevent incorrect operation  1

| |  | Nº |
|--|---|--------|
| SEC striker to prevent incorrect operation | | 822796 |

[16] Parallel Sliding and Tilt&Slide handle – interior handle, lockable (200 mm handle length)  1
Sliding door handle – exterior recessed grip (43 mm distance), not sh.  1

[17] SEC striker

| |  | Nº |
|-------------|---|---|
| Screw-on | | 798226 |
| | | |
| |  |  |
| ≤ 1072 | | 2 |
| 1073 – 1700 | | 3 |
| 1701 – 2100 | | 4 |
| > 2100 | | 5 |

[18] Buffer  2

| |  | Nº |
|----|--|--------|
| 14 | | 635307 |

[20] SEC MUL striker

| |  | Nº |
|-------------|---|---|
| 31.6 | | 833688 |
| | | |
| |  |  |
| ≤ 1072 | | 2 |
| 1073 – 1700 | | 3 |
| 1701 – 2100 | | 4 |
| > 2100 | | 5 |

[22] Drilling protection  1

| |  | Nº |
|---------------------|---|--------|
| Drilling protection | | 770965 |

[24] Pin for anti-pushback function  2

| |  | Nº |
|----|---|---------|
| 39 | | 2006891 |

[25] Centre closer for anti-pushback function  2

| |  |  | Nº |
|----|---|---|--------|
| 41 | | Left | 821687 |
| | | Right | 823736 |

INFO
DIN L: order right components.
DIN R: order left components.



[26] Striker for anti-pushback function  2

| | |
|---|--------|
|  | Nº |
| Striker for anti-pushback function | 810279 |

[27] Cover cap for SEC MUL striker / striker for anti-pushback function



| | | |
|---|---|--------|
|  |  | Nº |
| R01.1 | Natural silver | 828482 |
| R05.3 | Medium bronze | 828483 |
| R06.2 | Jet black | 809717 |
| R07.2 | Traffic white | 819351 |

| | |
|---|---|
|  |  |
| ≤ 1072 | 2 |
| 1073 – 1700 | 3 |
| 1701 – 2100 | 4 |
| > 2100 | 5 |

[33] Stopper, cannot be used in conjunction with a control unit with SoftOpen and SoftStop on the mullion side.  1

| | |
|---|--------|
|  | Nº |
| Stopper | 800196 |

[23] Sash adapter profile  1

| | | | |
|---|---|---|--------|
|  |  |  | Nº |
| 5800 | R01.1 | Natural silver | 897735 |

[28] Frame adapter profile  1









| | | | |
|---|---|---|--------|
|  |  |  | Nº |
| 5800 | R01.1 | Natural silver | 897734 |

Alternatively

[2b] VT espagnolette, lockable (alternative to 2a)  1

BS 25 for profile 9772

BS 35 for profile 9771



| | | | | | | | | | |
|---|---|---|---|---|---|---|---|---|----|
|  |  |  |  |  |  |  |  |  | Nº |
| 25 | 1801 – 2400 | 1890 | 200 | 1000 | 2 | V | Roto Sil | 798285 | |
| | 2401 – 2500 | 2290 | 200 | 1000 | 2 | V | Roto Sil | 798286 | |
| 35 | 1801 – 2400 | 1890 | 200 | 1000 | 2 | V | Roto Sil | 798034 | |
| | 2401 – 2500 | 2290 | 200 | 1000 | 2 | V | Roto Sil | 798055 | |

[37] Rubber buffer (alternative to 33)  2

| | |
|---|--------|
|  | Nº |
| 14 | 729179 |

Optional





[35] Brush holder

| | |
|---|---|
|  | Nº |
| Brush holder | 809520 |
|  |  |
| < 1060 | 2 |
| ≥ 1060 | 3 |

[80] Tilt protection device; for application ranges SRH:SRW = > 2:1 up to max. 3:1; can only be used without control unit with Soft function.  2

| | |
|---|--------|
|  | Nº |
| Tilt protection device | 897049 |

SKG info clip**, not sh.  1

| | | | | |
|---|---|---|---|--------|
|  |  |  |  | Nº |
| SKG** info clip | For clipping onto the gearbox | R07.2 | Traffic white | 331459 |



Application range

SRW: 710 – 1500 mm

SRH: 600 – 2500 mm

S.kg: max. 250 kg

| | | | | |
|--------------------------|---|------------|-----------|--------|
| [1a] Corner drive | | With E cam | | 6 |
| [1b] | | With V cam | | 2 |
| | | | Nº | |
| 1 | E | | | 260275 |
| 1 | V | | | 260272 |

| | | | |
|-----------------------------|--|--|---|
| [2a] VT espagnolette | | | 1 |
| BS 25 for profile 9772 | | | |
| BS 35 for profile 9771 | | | |

| | | | | | | | | Nº |
|-------------|-------------|------|------|------|---|---|--------|-----------|
| 25 | 600 – 800 | 690 | 200 | 263 | – | – | – | 793942 |
| | 801 – 1000 | 890 | 200 | 413 | – | – | – | 793943 |
| | 1001 – 1200 | 1090 | 200 | 513 | 1 | V | – | 793944 |
| | 1201 – 1600 | 1290 | 200 | 563 | 1 | V | – | 793975 |
| | 1601 – 1800 | 1690 | 200 | 563 | 1 | V | – | 793977 |
| | 1801 – 2400 | 1890 | 200 | 1000 | 2 | V | – | 793978 |
| 35 | 2401 – 2500 | 2290 | 200 | 1000 | 2 | V | – | 793980 |
| | 600 – 800 | 690 | 200 | 263 | – | – | – | 799045 |
| | 801 – 1000 | 890 | 200 | 413 | – | – | – | 798027 |
| | 1001 – 1200 | 1090 | 200 | 513 | 1 | V | – | 798028 |
| | 1201 – 1600 | 1290 | 200 | 563 | 1 | V | – | 798030 |
| | 1601 – 1800 | 1690 | 200 | 563 | 1 | V | – | 798031 |
| 1801 – 2400 | 1890 | 200 | 1000 | 2 | V | – | 798032 | |
| 2401 – 2500 | 2290 | 200 | 1000 | 2 | V | – | 798033 | |

| [3] VT espagnolette, second opening sash | | | 1 | | | | | |
|---|-------------|------|------|------|---|----------|----------|-----------|
| | | | | | | | | Nº |
| 40 | 600 – 800 | 690 | 200 | 263 | – | – | Roto Sil | 792143 |
| | 801 – 1000 | 890 | 200 | 413 | – | – | Roto Sil | 792144 |
| | 1001 – 1200 | 1090 | 200 | 513 | – | – | Roto Sil | 809645 |
| | 1201 – 1600 | 1290 | 200 | 563 | – | – | Roto Sil | 809646 |
| | 1601 – 1800 | 1690 | 200 | 563 | – | – | Roto Sil | 809648 |
| | 1801 – 2400 | 1890 | 200 | 1000 | – | – | Roto Sil | 809649 |
| 2401 – 2500 | 2290 | 200 | 1000 | – | – | Roto Sil | 809651 | |

Espagnolette extension, (SRH > 1401 mm; not sh.)

| | | | | Nº |
|-----|---|---|---|-----------|
| 200 | Y | – | – | 308267 |
| 400 | Y | – | – | 297858 |

Size-specific combinations:

| | | | | Nº |
|-------------|--------|---|---|-----------|
| ≤ 1400 | – | – | – | – |
| 1401 – 1600 | 200 KU | – | – | 308267 |
| 1601 – 2000 | – | – | – | – |
| 2001 – 2200 | 200 KU | – | – | 308267 |
| 2201 – 2400 | 400 KU | – | – | 297858 |
| 2401 – 2500 | 200 KU | – | – | 308267 |

Centre lock (CL)

| [5] CL component, horizontal | | | |
|-------------------------------------|---|---|-----------|
| | | | Nº |
| 200 | – | – | 308267 |
| 344 | 1 | V | 572665 |
| 480 | – | – | 245729 |
| 590 | – | – | 603442 |
| 790 | 1 | E | 603444 |
| 990 | 1 | E | 603447 |
| 1190 | 1 | E | 603462 |
| 1440 | 1 | E | 603466 |

Size-specific combinations:

First or second opening sash

| | | | | Nº |
|-------------|------|---|---|-----------|
| ≤ 760 | 344 | 1 | V | 572665 |
| 761 – 860 | 480 | – | – | 245729 |
| 861 – 1060 | 590 | – | – | 603442 |
| 1061 – 1260 | 790 | 1 | E | 603444 |
| 1261 – 1460 | 990 | 1 | E | 603447 |
| 1461 – 1660 | 1190 | 1 | E | 603462 |
| 1661 – 1910 | 1440 | 1 | E | 603466 |
| ≥ 1911 | 1440 | 1 | E | 603466 |
| | 200 | – | – | 308267 |

| [6] Centre lock component 130, horizontal and vertical | | | | | 8 |
|---|---|---|---|-----------|---|
| | | | | Nº | |
| 130 | Y | 1 | E | 764350 | |

| [7] CL component, vertical, on the mullion | | | | |
|---|---|---|---|-----------|
| | | | | Nº |
| 200 | Y | – | – | 308267 |
| | Y | 1 | E | 450821 |
| 400 | Y | – | – | 297858 |
| 600 | Y | 1 | E | 255282 |
| | N | 1 | E | 255281 |





Size-specific combinations:

First opening sash:



| | | | | Nº |
|-------------|--------|---|---|-----------|
| 1201 – 1800 | 600 | 1 | E | 255281 |
| 1801 – 2000 | 200 KU | – | – | 308267 |
| | 600 | 1 | E | 255281 |
| 2001 – 2200 | 400 KU | – | – | 297858 |
| | 600 | 1 | E | 255281 |
| 2201 – 2400 | 200 KU | 1 | E | 450821 |
| | 400 KU | – | – | 297858 |
| | 600 | 1 | E | 255281 |

|  |  |  |  | Nº |
|---|---|---|---|--------|
| 2401 – 2500 | 200 KU | – | – | 308267 |
| | 600 KU | 1 | E | 255282 |
| | 200 KU | – | – | 308267 |
| | 600 | 1 | E | 255281 |

Second opening sash:

|  |  |  |  | Nº |
|---|---|---|---|--------|
| 600 – 1200 | 200 KU | 1 | E | 450821 |
| | 1201 – 1800 | 600 KU | 1 | E |
| 1801 – 2000 | 200 KU | 1 | E | 450821 |
| | 200 KU | – | – | 308267 |
| | 600 KU | 1 | E | 255282 |
| 2001 – 2200 | 200 KU | 1 | E | 450821 |
| | 400 KU | – | – | 297858 |
| | 600 KU | 1 | E | 255282 |
| 2201 – 2400 | 200 KU | 1 | E | 450821 |
| | 200 KU | 1 | E | 450821 |
| | 400 KU | – | – | 297858 |
| 2401 – 2500 | 600 KU | 1 | E | 255282 |
| | 200 KU | 1 | E | 450821 |
| | 200 KU | – | – | 308267 |
| | 600 KU | 1 | E | 255282 |
| | 200 KU | 1 | E | 450821 |



[8] Roller track  1

|  |  |  | Nº |
|---|---|---|---------|
| 3200 | Natural silver | R01.1 | 2006845 |
| 6400 | Natural silver | R01.1 | 2006884 |

[9] Roller unit

|  |  | Nº |
|---|---|--------|
| 41 | Left | 821686 |
| | Right | 823733 |



|  | Nº |
|---|----|
| < 1060 | 4 |
| ≥ 1060 | 6 |

[10] Control unit, on the mullion side and in the centre  2-4
 Alternatively (on the mullion side):
 Control unit set with Soft function → *from page 158*  2
 Activator for Soft function can be used with an asymmetrical screw fixing → *from page 159*  2

|  |  | Nº |
|---|---|--------|
| 41 | Left | 821685 |
| | Right | 823730 |

[*] Control unit set with Soft function, on the locking side → from page 158  2
 Alternatively:
[10] Control unit

Contents:

|  |  | # |
|---|---|---|
| [29] | Activator | 1 |
| [30] | Control unit with Soft function | 1 |

[11] Centre closer

|  |  | Nº |
|---|---|--------|
| 41 | Left | 821687 |
| | Right | 823736 |



|  |  |
|---|---|
| ≤ 1200 | 4 |
| 1201 – 2400 | 6 |
| > 2400 | 8 |

[12] MUL locking cam

|  | Nº |
|---|---------|
| 39 | 2006890 |



|  |  |
|---|---|
| ≤ 1200 | 4 |
| 1201 – 2400 | 6 |
| > 2400 | 8 |

[14] Guide track  1

|  |  |  | Nº |
|---|---|---|---------|
| 3200 | Natural silver | R01.1 | 2006846 |
| 6400 | Natural silver | R01.1 | 2006885 |



[15] Striker to prevent incorrect operation  1

|  | Nº |
|---|--------|
| Striker to prevent incorrect operation | 822789 |

[16] Parallel Sliding and Tilt&Slide handle – interior handle (200 mm handle length)  2
Sliding door handle – exterior recessed grip (43 mm distance), not sh.  2

[17] Striker

|  | Nº |
|---|--------|
| Screw-on | 744579 |

|  |  |
|---|---|
| ≤ 1200 | 2 |
| 1201 – 2400 | 3 |
| > 2400 | 4 |



[18] Buffer  2

| | |
|---|--------|
|  | Nº |
| 14 | 635307 |



[20] MUL striker

| | |
|---|--------|
|  | Nº |
| Screw-on | 793493 |

| | |
|---|---|
|  |  |
| ≤ 1200 | 4 |
| 1201 – 2400 | 6 |
| > 2400 | 8 |

[21] Cover cap for MUL striker, only in combination with MUL striker, screw-on.

| | | |
|---|---|--------|
|  |  | Nº |
| R01.1 | Natural silver | 819632 |
| R05.3 | Medium bronze | 819631 |
| R06.2 | Jet black | 798979 |
| R07.2 | Traffic white | 808054 |

| | |
|---|---|
|  |  |
| ≤ 1200 | 4 |
| 1201 – 2400 | 6 |
| > 2400 | 8 |

[*] Operating sequence control set  1
SRH ≥ 1200 mm, profile-related

| | |
|---|---------|
|  | Nº |
| For widths > 40 mm | 2029689 |

| | |
|--|----------|
| [*]  | # |
| [42] Trapezoid with M5 x 20 cylinder screw | 1 |
| [43] Anti-lifting device | 1 |
| [44] Striker with buffer | 1 |

[24] Pin for anti-pushback function  2

| | |
|---|---------|
|  | Nº |
| 39.5 | 2009506 |

[25] Centre closer for anti-pushback function  1

| | | |
|---|---|--------|
|  |  | Nº |
| 41 | Left | 821687 |
| | Right | 823736 |



INFO



DIN L: order right components.

DIN R: order left components.

[26] Striker for anti-pushback function  1

| | |
|---|--------|
|  | Nº |
| Striker for anti-pushback function | 810279 |

[27] Cover cap for striker for anti-pushback function  1

| | | |
|---|--|--------|
|  |  | Nº |
| R01.1 | Natural silver | 828482 |
| R05.3 | Medium bronze | 828483 |
| R06.2 | Jet black | 809717 |
| R07.2 | Traffic white | 819351 |



[33] Stopper, cannot be used in conjunction with a control unit with SoftOpen and SoftStop on the mullion side.  1

| | |
|---|--------|
|  | Nº |
| Stopper | 800196 |

[23] Sash adapter profile  1

| | | | |
|---|---|---|---------|
|  |  |  | Nº |
| 3200 | Natural silver | R01.1 | 2006848 |
| 6400 | Natural silver | R01.1 | 2006887 |

[28] Frame adapter profile  1







| | | | |
|---|---|---|---------|
|  |  |  | Nº |
| 3200 | Natural silver | R01.1 | 2006847 |
| 6400 | Natural silver | R01.1 | 2006886 |

Alternatively

[2b] VT espagnolette, lockable (alternative to 2a)  1

BS 25 for profile 9772

BS 35 for profile 9771

| | | | | | | | |
|---|---|--|---|---|---|---|-----------------|
|  |  |  |  |  |  |  | Nº |
| 25 | 1801 – 2400 | 1890 | 200 | 1000 | 2 | V | Roto Sil 798285 |
| | 2401 – 2500 | 2290 | 200 | 1000 | 2 | V | Roto Sil 798286 |
| 35 | 1801 – 2400 | 1890 | 200 | 1000 | 2 | V | Roto Sil 798034 |
| | 2401 – 2500 | 2290 | 200 | 1000 | 2 | V | Roto Sil 798055 |

[37] Rubber buffer (alternative to 33)  4

| | |
|---|--------|
|  | Nº |
| 14 | 729179 |

Optional

[35] Brush holder

| | |
|---|--------|
|  | Nº |
| Brush holder | 809520 |

| | |
|---|---|
|  |  |
| < 1060 | 4 |
| ≥ 1060 | 6 |

[80] **Tilt protection device**; for application ranges SRH:SRW = > 2:1 up to max. 3:1; can only be used without control unit with Soft function.  4



Nº

Tilt protection device

897049



4.2.7 ASAŞ | Inova

4.2.7.1 Diagram A, K

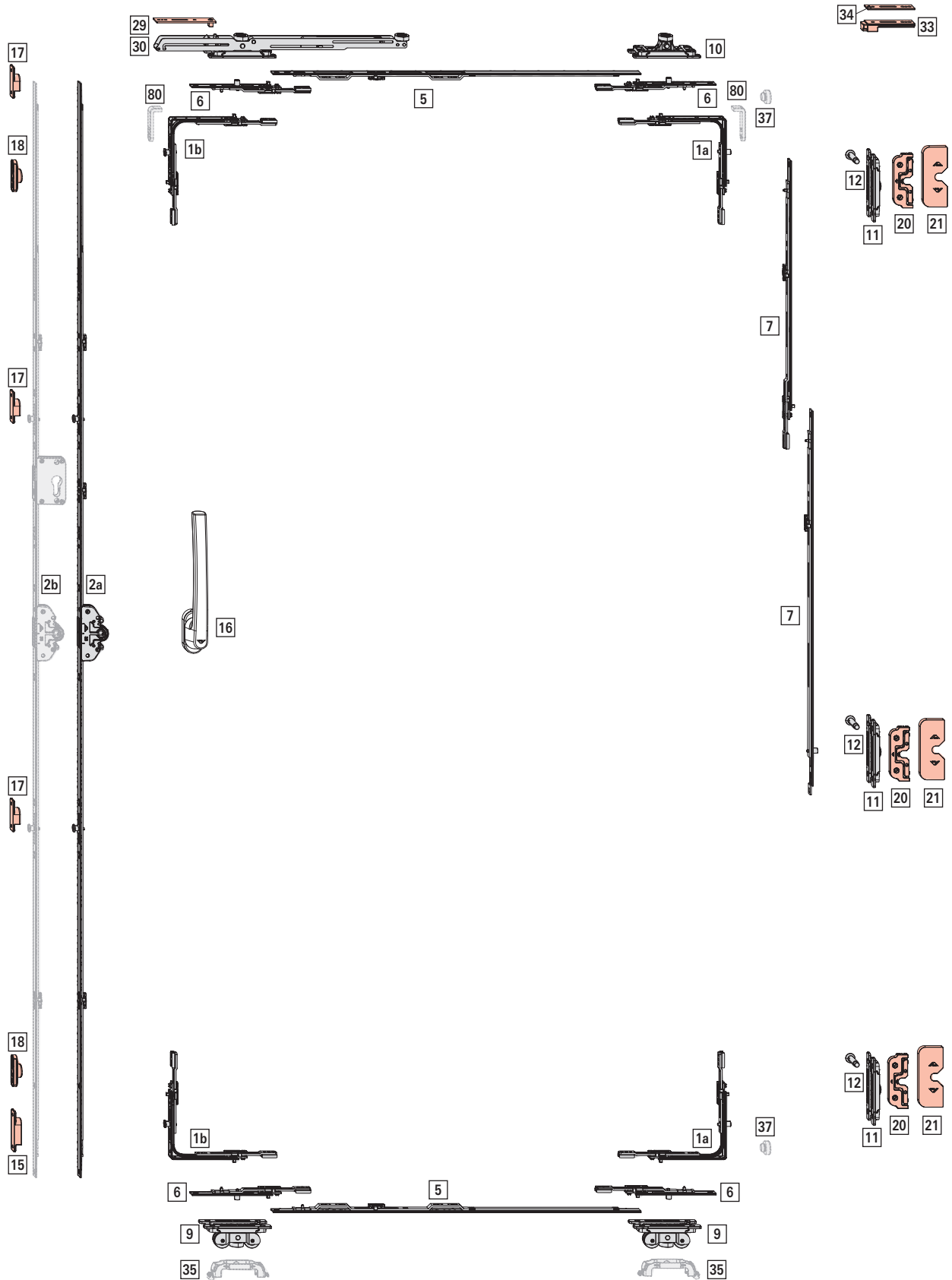



Application range

SRW: 710 – 2000 mm

SRH: 600 – 2500 mm

S.kg: max. 200 kg

| | | | |
|--------------------------|------------|--|---|
| [1a] Corner drive | With E cam | | 2 |
| [1b] | With V cam | | 2 |

| | | Nº |
|---|---|--------|
| 1 | E | 260275 |
| 1 | V | 260272 |

[2a] VT espagnolette

| | | | | | | | | Nº |
|----|-------------|------|-----|------|---|---|----------|--------|
| 40 | 600 – 800 | 690 | 200 | 263 | – | – | Roto Sil | 792143 |
| | 801 – 1000 | 890 | 200 | 413 | – | – | Roto Sil | 792144 |
| | 1001 – 1200 | 1090 | 200 | 513 | 1 | V | Roto Sil | 792185 |
| | 1201 – 1600 | 1290 | 200 | 563 | 1 | V | Roto Sil | 792188 |
| | 1601 – 1800 | 1690 | 200 | 563 | 1 | V | Roto Sil | 792190 |
| | 1801 – 2400 | 1890 | 200 | 1000 | 2 | V | Roto Sil | 792191 |
| | 2401 – 2500 | 2290 | 200 | 1000 | 2 | V | Roto Sil | 792193 |

Espagnolette extension, (SRH > 1401 mm; not sh.)

| | | | | Nº |
|-----|---|---|---|--------|
| 200 | Y | – | – | 308267 |
| 400 | Y | – | – | 297858 |

Size-specific combinations:

| | | | | Nº |
|-------------|--------|---|---|--------|
| ≤ 1400 | – | – | – | – |
| 1401 – 1600 | 200 KU | – | – | 308267 |
| 1601 – 2000 | – | – | – | – |
| 2001 – 2200 | 200 KU | – | – | 308267 |
| 2201 – 2400 | 400 KU | – | – | 297858 |
| 2401 – 2500 | 200 KU | – | – | 308267 |

Centre lock (CL)

[5] CL component, horizontal

| | | | Nº |
|------|---|---|--------|
| 200 | – | – | 308267 |
| 344 | 1 | V | 572665 |
| 480 | – | – | 245729 |
| 590 | – | – | 603442 |
| 790 | 1 | E | 603444 |
| 990 | 1 | E | 603447 |
| 1190 | 1 | E | 603462 |
| 1440 | 1 | E | 603466 |

Size-specific combinations:

| | | | | Nº |
|-------|-----|---|---|--------|
| ≤ 760 | 344 | 1 | V | 572665 |

| | | | | Nº |
|-------------|------|---|---|--------|
| 761 – 860 | 480 | – | – | 245729 |
| 861 – 1060 | 590 | – | – | 603442 |
| 1061 – 1260 | 790 | 1 | E | 603444 |
| 1261 – 1460 | 990 | 1 | E | 603447 |
| 1461 – 1660 | 1190 | 1 | E | 603462 |
| 1661 – 1910 | 1440 | 1 | E | 603466 |
| ≥ 1911 | 1440 | 1 | E | 603466 |
| | 200 | – | – | 308267 |

[6] Centre lock component 130, horizontal

| | | | | Nº |
|-----|---|---|---|--------|
| 130 | Y | 1 | E | 764350 |

[7] CL component, vertical, on the mullion

| | | | | Nº |
|-----|---|---|---|--------|
| 200 | Y | – | – | 308267 |
| | Y | 1 | E | 450821 |
| 400 | Y | – | – | 297858 |
| 600 | Y | 1 | E | 255282 |
| | N | 1 | E | 255281 |

Size-specific combinations:

| | | | | Nº |
|-------------|--------|---|---|--------|
| 1201 – 1800 | 600 | 1 | E | 255281 |
| 1801 – 2000 | 200 KU | – | – | 308267 |
| | 600 | 1 | E | 255281 |
| 2001 – 2200 | 400 KU | – | – | 297858 |
| | 600 | 1 | E | 255281 |
| 2201 – 2400 | 200 KU | 1 | E | 450821 |
| | 400 KU | – | – | 297858 |
| | 600 | 1 | E | 255281 |
| 2401 – 2500 | 200 KU | – | – | 308267 |
| | 600 KU | 1 | E | 255282 |
| | 200 KU | – | – | 308267 |
| | 600 | 1 | E | 255281 |

[9] Roller unit

| | | Nº |
|----|-------|--------|
| 41 | Left | 821686 |
| | Right | 823733 |

| < 1060 | 2 |
|--------|---|
| ≥ 1060 | 3 |

[10] Control unit, on the mullion side and in the centre

→ *from page 158*
 Alternatively (on the mullion side):
 Control unit set with Soft function (incl. activator) → *from page 158*

| | | Nº |
|----|-------|--------|
| 41 | Left | 821686 |
| | Right | 823730 |

[*] Control unit set with Soft function, on the locking side → *from page 158*  1
Alternatively:
[10] Control unit 

Contents:

| [*] |  | # |
|------|---|---|
| [29] | Activator | 1 |
| [30] | Control unit with Soft function | 1 |

[11] Centre closer

|  |  | Nº |
|---|---|--------|
| 41 | Left | 821687 |
| | Right | 823736 |

|  |  |
|---|---|
| ≤ 1200 | 2 |
| 1201 – 2400 | 3 |
| > 2400 | 4 |



[12] MUL locking cam

|  | Nº |
|---|--------|
| 33.5 | 819884 |

|  |  |
|---|---|
| ≤ 1200 | 2 |
| 1201 – 2400 | 3 |
| > 2400 | 4 |

[15] Striker to prevent incorrect operation  1

|  | Nº |
|---|--------|
| Striker to prevent incorrect operation | 822789 |

[16] Parallel Sliding and Tilt&Slide handle – interior handle (200 mm handle length)  1
Sliding door handle – exterior recessed grip (43 mm distance), not sh. 

[17] Striker

|  | Nº |
|---|--------|
| Screw-on | 744579 |



|  |  |
|---|---|
| ≤ 1200 | 2 |
| 1201 – 2400 | 3 |
| > 2400 | 4 |

[18] Buffer  2

|  | Nº |
|---|--------|
| 14 | 635307 |

[20] MUL striker

|  | Nº |
|---|--------|
| Screw-on | 793493 |

|  |  |
|---|---|
| ≤ 1200 | 2 |
| 1201 – 2400 | 3 |
| > 2400 | 4 |

[21] Cover cap for MUL striker, only in combination with MUL striker, screw-on.

|  |  | Nº |
|---|--|--------|
| R01.1 | Natural silver | 819632 |
| R05.3 | Medium bronze | 819631 |
| R06.2 | Jet black | 798979 |
| R07.2 | Traffic white | 808054 |

|  |  |
|---|---|
| ≤ 1200 | 2 |
| 1201 – 2400 | 3 |
| > 2400 | 4 |

[33] Stopper, cannot be used in conjunction with a control unit with SoftOpen and SoftStop on the mullion side.  1



|  | Nº |
|---|--------|
| Stopper | 800196 |

[34] Packer  1

|  | Nº |
|---|--------|
| Packer | 800197 |

Alternatively

[2b] VT espagnolette, lockable (alternative to 2a)  1

|  |  |  |  |  |  |  |  | Nº |
|---|---|---|---|---|---|---|---|--------|
| 40 | 1801 – 2400 | 1890 | 200 | 1000 | 2 | V | Roto Sil | 795603 |
| | 2401 – 2500 | 2290 | 200 | 1000 | 2 | V | Roto Sil | 795604 |

[37] Rubber buffer (alternative to 33)  2

|  | Nº |
|---|--------|
| 14 | 729179 |



Optional

[35] Brush holder



Nº

Brush holder 809520



< 1060 2

≥ 1060 3

[80] Tilt protection device; for application ranges SRH:SRW = > 2:1 up to max. 3:1; can only be used without control unit with Soft function.  2



Nº

Tilt protection device 897049

4.2.7.2 Diagram A – RC 2 / RC 2 N





Application range

SRW: 710 – 2000 mm

SRH: 1072 – 2500 mm

S.kg: max. 200 kg

| | | | |
|--------------------------|------------|--|---|
| [1a] Corner drive | With E cam | | 2 |
| [1b] | With V cam | | 2 |

| | | Nº |
|---|---|--------|
| 1 | E | 260275 |
| 1 | V | 260272 |

[2a] VT espagnolette

| | | | | | | | | Nº |
|----|-------------|------|-----|------|---|---|----------|--------|
| 40 | 600 – 800 | 690 | 200 | 263 | – | – | Roto Sil | 792143 |
| | 801 – 1000 | 890 | 200 | 413 | – | – | Roto Sil | 792144 |
| | 1001 – 1200 | 1090 | 200 | 513 | 1 | V | Roto Sil | 792185 |
| | 1201 – 1600 | 1290 | 200 | 563 | 1 | V | Roto Sil | 792188 |
| | 1601 – 1800 | 1690 | 200 | 563 | 1 | V | Roto Sil | 792190 |
| | 1801 – 2400 | 1890 | 200 | 1000 | 2 | V | Roto Sil | 792191 |
| | 2401 – 2500 | 2290 | 200 | 1000 | 2 | V | Roto Sil | 792193 |

Espagnolette extension, (SRH > 1401 mm; not sh.)

| | | | | Nº |
|-----|---|---|---|--------|
| 200 | Y | – | – | 308267 |
| 400 | Y | – | – | 297858 |

Size-specific combinations:

| | | | | Nº |
|-------------|--------|---|---|--------|
| ≤ 1400 | – | – | – | – |
| 1401 – 1600 | 200 KU | – | – | 308267 |
| 1601 – 2000 | – | – | – | – |
| 2001 – 2200 | 200 KU | – | – | 308267 |
| 2201 – 2400 | 400 KU | – | – | 297858 |
| 2401 – 2500 | 200 KU | – | – | 308267 |

Centre lock (CL)

[5] CL component, horizontal

| | | | Nº |
|------|---|---|--------|
| 200 | – | – | 308267 |
| 344 | 1 | V | 572665 |
| 480 | – | – | 245729 |
| 590 | – | – | 603442 |
| 790 | 1 | E | 603444 |
| 990 | 1 | E | 603447 |
| 1190 | 1 | E | 603462 |
| 1440 | 1 | E | 603466 |

Size-specific combinations:

| | | | | Nº |
|-------|-----|---|---|--------|
| ≤ 760 | 344 | 1 | V | 572665 |

| | | | | Nº |
|-------------|------|---|---|--------|
| 761 – 860 | 480 | – | – | 245729 |
| 861 – 1060 | 590 | – | – | 603442 |
| 1061 – 1260 | 790 | 1 | E | 603444 |
| 1261 – 1460 | 990 | 1 | E | 603447 |
| 1461 – 1660 | 1190 | 1 | E | 603462 |
| 1661 – 1910 | 1440 | 1 | E | 603466 |
| ≥ 1911 | 1440 | 1 | E | 603466 |
| | 200 | – | – | 308267 |

[6] Centre lock component 130, horizontal

| | | | | Nº |
|-----|---|---|---|--------|
| 130 | Y | 1 | E | 764350 |

[7] CL component, vertical, on the mullion

| | | | | Nº |
|-----|---|---|---|--------|
| 200 | Y | – | – | 308267 |
| | Y | 1 | E | 450821 |
| 400 | Y | – | – | 297858 |
| 600 | Y | 1 | E | 255282 |
| | N | 1 | E | 255281 |

Size-specific combinations:

| | | | | Nº |
|-------------|--------|---|---|--------|
| 1201 – 1800 | 600 | 1 | E | 255281 |
| 1801 – 2000 | 200 KU | – | – | 308267 |
| | 600 | 1 | E | 255281 |
| 2001 – 2200 | 400 KU | – | – | 297858 |
| | 600 | 1 | E | 255281 |
| 2201 – 2400 | 200 KU | 1 | E | 450821 |
| | 400 KU | – | – | 297858 |
| | 600 | 1 | E | 255281 |
| 2401 – 2500 | 200 KU | – | – | 308267 |
| | 600 KU | 1 | E | 255282 |
| | 200 KU | – | – | 308267 |
| | 600 | 1 | E | 255281 |

[9] Roller unit

| | | Nº |
|----|-------|--------|
| 41 | Left | 821686 |
| | Right | 823733 |

| | Nº |
|--------|----|
| < 1060 | 2 |
| ≥ 1060 | 3 |

[10] Control unit, on the mullion side and in the centre **1-2**
 → *from page 158*
 Alternatively (on the mullion side):
 Control unit set with Soft function (incl. activator) **1**
 → *from page 158*



| | | Nº |
|----|-------|--------|
| 41 | Left | 821686 |
| | Right | 823730 |



[*] Control unit set with Soft function, on the locking side → *from page 158*  1
Alternatively:
[10] Control unit

Contents:

| [*] |  | # |
|------|---|---|
| [29] | Activator | 1 |
| [30] | Control unit with Soft function | 1 |



[11] Centre closer

|  |  | Nº |
|---|---|--------|
| 41 | Left | 821687 |
| | Right | 823736 |

|  |  |
|---|---|
| ≤ 1072 | 2 |
| 1073 – 1700 | 3 |
| 1701 – 2100 | 4 |
| > 2100 | 5 |



[12] MUL locking cam

|  | Nº |
|---|--------|
| 33.5 | 819884 |

|  |  |
|---|---|
| ≤ 1072 | 2 |
| 1073 – 1700 | 3 |
| 1701 – 2100 | 4 |
| > 2100 | 5 |



[15] SEC striker to prevent incorrect operation  1

|  | Nº |
|---|--------|
| SEC striker to prevent incorrect operation | 822796 |

[16] Parallel Sliding and Tilt&Slide handle – interior handle, lockable (200 mm handle length)  1
Sliding door handle – exterior recessed grip (43 mm distance), not sh.  1

[17] SEC striker

|  | Nº |
|---|--------|
| Screw-on | 798226 |



|  |  |
|---|---|
| ≤ 1072 | 2 |
| 1073 – 1700 | 3 |
| 1701 – 2100 | 4 |
| > 2100 | 5 |

[18] Buffer  2

|  | Nº |
|---|--------|
| 14 | 635307 |

[20] SEC MUL striker

|  | Nº |
|---|--------|
| 31.6 | 833688 |

|  |  |
|---|---|
| ≤ 1072 | 2 |
| 1073 – 1700 | 3 |
| 1701 – 2100 | 4 |
| > 2100 | 5 |



[22] Drilling protection  1

|  | Nº |
|---|--------|
| Drilling protection | 770965 |

[24] Pin for anti-pushback function  2

|  | Nº |
|---|--------|
| 34 | 822393 |

[25] Centre closer for anti-pushback function  2



|  |  | Nº |
|---|---|--------|
| 41 | Left | 821687 |
| | Right | 823736 |

INFO
DIN L: order right components.
DIN R: order left components.

[26] Striker for anti-pushback function  2

|  | Nº |
|---|--------|
| Striker for anti-pushback function | 810279 |

[27] Cover cap for SEC MUL striker / striker for anti-pushback function



|  |  | Nº |
|---|--|--------|
| R01.1 | Natural silver | 828482 |
| R05.3 | Medium bronze | 828483 |
| R06.2 | Jet black | 809717 |
| R07.2 | Traffic white | 819351 |

|  |  |
|---|---|
| ≤ 1072 | 2 |
| 1073 – 1700 | 3 |
| 1701 – 2100 | 4 |
| > 2100 | 5 |









[33] Stopper, cannot be used in conjunction with a control unit with SoftOpen and SoftStop on the mullion side.  1



|  | Nº |
|---|--------|
| Stopper | 800196 |





| | |
|--|--------|
| [34] Packer  | |
|  | Nº |
| Packer | 800197 |



Alternatively





| | |
|--|---|
| [2b] VT espagnolette, lockable (alternative to 2a)  | |
|         Nº | |
| 40 | 1801 – 2400 1890 200 1000 2 V Roto Sil 795603 |
| | 2401 – 2500 2290 200 1000 2 V Roto Sil 795604 |

| | |
|---|--------|
| [37] Rubber buffer (alternative to 33)  | |
|  | Nº |
| 14 | 729179 |

Optional

| | |
|---|---|
| [35] Brush holder | |
|  | Nº |
| Brush holder | 809520 |
|  |  |
| < 1060 | 2 |
| ≥ 1060 | 3 |

| | |
|---|--------|
| [80] Tilt protection device; for application ranges SRH:SRW = > 2:1 up to max. 3:1; can only be used without control unit with Soft function.  | |
|  | Nº |
| Tilt protection device | 897049 |

| | |
|--|----------------------------|
| SKG** info clip, not sh.  | |
|     Nº | |
| SKG** info clip For clipping onto the gearbox | R07.2 Traffic white 331459 |

4.2.7.3 Diagram C

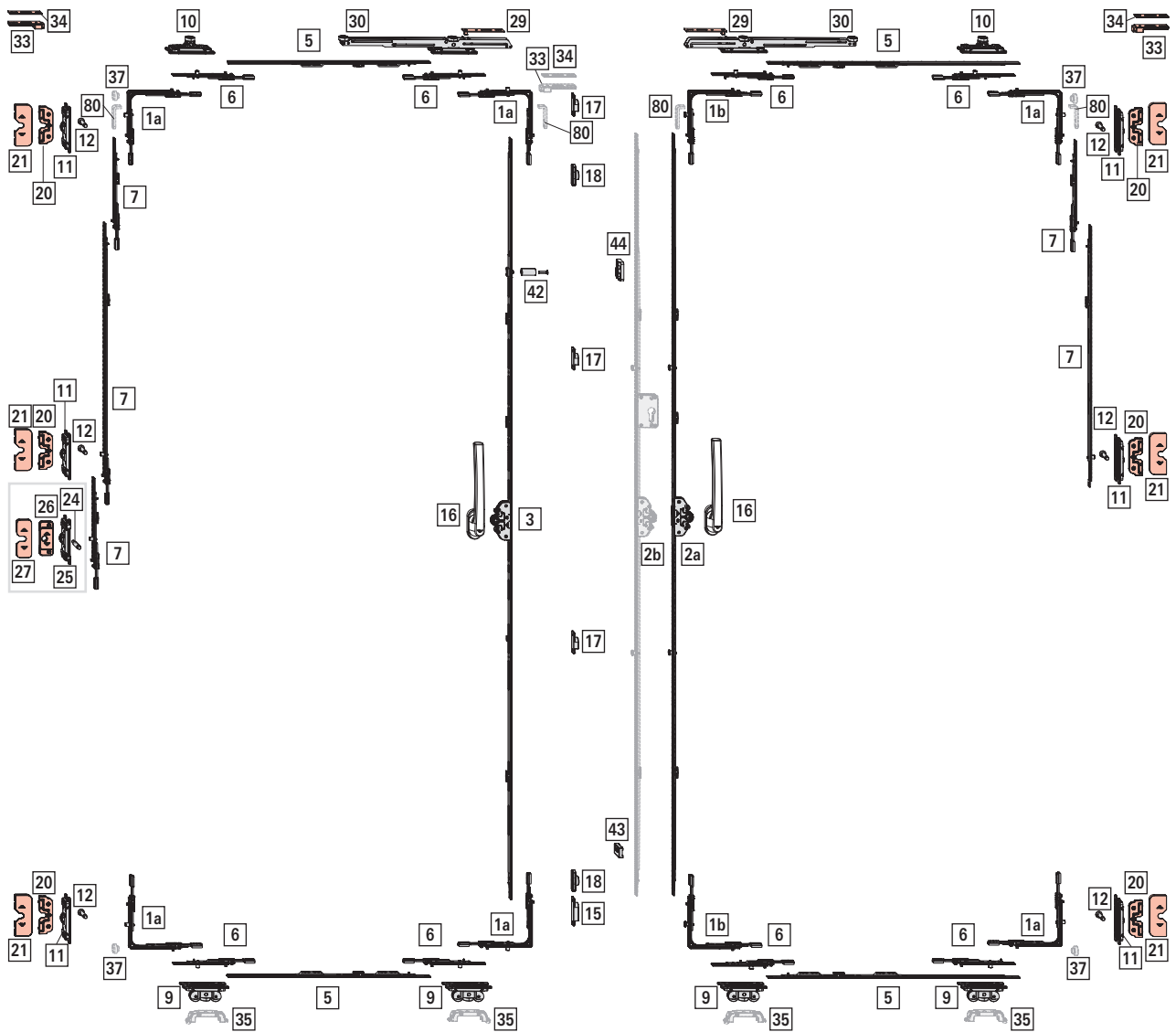



Application range

SRW: 710 – 1500 mm

SRH: 600 – 2500 mm

S.kg: max. 200 kg

| | | | |
|--------------------------|------------|--|---|
| [1a] Corner drive | With E cam | | 6 |
| [1b] | With V cam | | 2 |

| | | Nº |
|---|---|--------|
| 1 | E | 260275 |
| 1 | V | 260272 |

[2a] VT espagnolette

| | | | | | | | | Nº |
|----|-------------|------|-----|------|---|---|----------|--------|
| 40 | 600 – 800 | 690 | 200 | 263 | – | – | Roto Sil | 792143 |
| | 801 – 1000 | 890 | 200 | 413 | – | – | Roto Sil | 792144 |
| | 1001 – 1200 | 1090 | 200 | 513 | 1 | V | Roto Sil | 792185 |
| | 1201 – 1600 | 1290 | 200 | 563 | 1 | V | Roto Sil | 792188 |
| | 1601 – 1800 | 1690 | 200 | 563 | 1 | V | Roto Sil | 792190 |
| | 1801 – 2400 | 1890 | 200 | 1000 | 2 | V | Roto Sil | 792191 |
| | 2401 – 2500 | 2290 | 200 | 1000 | 2 | V | Roto Sil | 792193 |

[3] VT espagnolette, second opening sash

| | | | | | | | | Nº |
|----|-------------|------|-----|------|---|---|----------|--------|
| 40 | 600 – 800 | 690 | 200 | 263 | – | – | Roto Sil | 792143 |
| | 801 – 1000 | 890 | 200 | 413 | – | – | Roto Sil | 792144 |
| | 1001 – 1200 | 1090 | 200 | 513 | – | – | Roto Sil | 809645 |
| | 1201 – 1600 | 1290 | 200 | 563 | – | – | Roto Sil | 809646 |
| | 1601 – 1800 | 1690 | 200 | 563 | – | – | Roto Sil | 809648 |
| | 1801 – 2400 | 1890 | 200 | 1000 | – | – | Roto Sil | 809649 |
| | 2401 – 2500 | 2290 | 200 | 1000 | – | – | Roto Sil | 809651 |

Espagnolette extension, (SRH > 1401 mm; not sh.)

| | | | | Nº |
|-----|---|---|---|--------|
| 200 | Y | – | – | 308267 |
| 400 | Y | – | – | 297858 |

Size-specific combinations:

| | | | | Nº |
|-------------|--------|---|---|--------|
| ≤ 1400 | – | – | – | – |
| 1401 – 1600 | 200 KU | – | – | 308267 |
| 1601 – 2000 | – | – | – | – |
| 2001 – 2200 | 200 KU | – | – | 308267 |
| 2201 – 2400 | 400 KU | – | – | 297858 |
| 2401 – 2500 | 200 KU | – | – | 308267 |

Centre lock (CL)

[5] CL component, horizontal

| | | | Nº |
|-----|---|---|--------|
| 200 | – | – | 308267 |
| 344 | 1 | V | 572665 |

| | | | Nº |
|------|---|---|--------|
| 480 | – | – | 245729 |
| 590 | – | – | 603442 |
| 790 | 1 | E | 603444 |
| 990 | 1 | E | 603447 |
| 1190 | 1 | E | 603462 |
| 1440 | 1 | E | 603466 |

Size-specific combinations:

First or second opening sash

| | | | | Nº |
|-------------|------|---|---|--------|
| ≤ 760 | 344 | 1 | V | 572665 |
| 761 – 860 | 480 | – | – | 245729 |
| 861 – 1060 | 590 | – | – | 603442 |
| 1061 – 1260 | 790 | 1 | E | 603444 |
| 1261 – 1460 | 990 | 1 | E | 603447 |
| 1461 – 1660 | 1190 | 1 | E | 603462 |
| 1661 – 1910 | 1440 | 1 | E | 603466 |
| ≥ 1911 | 1440 | 1 | E | 603466 |
| | 200 | – | – | 308267 |

[6] Centre lock component 130, horizontal and vertical

| | | | | Nº |
|-----|---|---|---|--------|
| 130 | Y | 1 | E | 764350 |

[7] CL component, vertical, on the mullion

| | | | | Nº |
|-----|---|---|---|--------|
| 200 | Y | – | – | 308267 |
| | Y | 1 | E | 450821 |
| 400 | Y | – | – | 297858 |
| 600 | Y | 1 | E | 255282 |
| | N | 1 | E | 255281 |





Size-specific combinations:

First opening sash:

| | | | | Nº |
|-------------|--------|---|---|--------|
| 1201 – 1800 | 600 | 1 | E | 255281 |
| 1801 – 2000 | 200 KU | – | – | 308267 |
| | 600 | 1 | E | 255281 |
| 2001 – 2200 | 400 KU | – | – | 297858 |
| | 600 | 1 | E | 255281 |
| 2201 – 2400 | 200 KU | 1 | E | 450821 |
| | 400 KU | – | – | 297858 |
| | 600 | 1 | E | 255281 |
| 2401 – 2500 | 200 KU | – | – | 308267 |
| | 600 KU | 1 | E | 255282 |
| | 200 KU | – | – | 308267 |
| | 600 | 1 | E | 255281 |

Second opening sash:



| | | | | Nº |
|------------|--------|---|---|--------|
| 600 – 1200 | 200 KU | 1 | E | 450821 |

|  |  |  |  | Nº |
|---|---|---|---|--------|
| 1201 – 1800 | 600 KU | 1 | E | 255282 |
| | 200 KU | 1 | E | 450821 |
| 1801 – 2000 | 200 KU | – | – | 308267 |
| | 600 KU | 1 | E | 255282 |
| 2001 – 2200 | 200 KU | 1 | E | 450821 |
| | 400 KU | – | – | 297858 |
| 2201 – 2400 | 600 KU | 1 | E | 255282 |
| | 200 KU | 1 | E | 450821 |
| 2401 – 2500 | 200 KU | – | – | 308267 |
| | 600 KU | 1 | E | 255282 |
| | 200 KU | – | – | 308267 |
| | 600 KU | 1 | E | 255282 |
| | 200 KU | 1 | E | 450821 |

[9] Roller unit

|  |  | Nº |
|--|--|--------|
| 41 | Left | 821686 |
| | Right | 823733 |



|  |  |
|---|---|
| < 1060 | 4 |
| ≥ 1060 | 6 |

[10] Control unit, on the mullion side and in the centre → *from page 158*  2-4
 Alternatively (on the mullion side):
 Control unit set with Soft function (incl. activator) → *from page 158*  1-2



|  |  | Nº |
|---|---|--------|
| 41 | Left | 821685 |
| | Right | 823730 |

[*] Control unit set with Soft function, on the locking side → *from page 158*  2
 Alternatively:
 [10] Control unit 

Contents:

|  |  | # |
|---|---|---|
| [29] | Activator | 1 |
| [30] | Control unit with Soft function | 1 |

[11] Centre closer

|  |  | Nº |
|---|---|--------|
| 41 | Left | 821687 |

|  |  | Nº |
|---|---|--------|
| | Right | 823736 |

|  |  |
|---|---|
| ≤ 1200 | 4 |
| 1201 – 2400 | 6 |
| > 2400 | 8 |



[12] MUL locking cam

|  | Nº |
|---|--------|
| 33.5 | 819884 |

|  |  |
|---|---|
| ≤ 1200 | 4 |
| 1201 – 2400 | 6 |
| > 2400 | 8 |

[15] Striker to prevent incorrect operation  1

|  | Nº |
|---|--------|
| Striker to prevent incorrect operation | 822789 |

[16] Parallel Sliding and Tilt&Slide handle – interior handle (200 mm handle length)  2
Sliding door handle – exterior recessed grip (43 mm distance), not sh.  2

[17] Striker

|  | Nº |
|---|--------|
| Screw-on | 744579 |



|  |  |
|---|---|
| ≤ 1200 | 2 |
| 1201 – 2400 | 3 |
| > 2400 | 4 |

[18] Buffer  2



|  | Nº |
|---|--------|
| 14 | 635307 |

[20] MUL striker





|  | Nº |
|---|--------|
| Screw-on | 793493 |

|  |  |
|---|---|
| ≤ 1200 | 4 |
| 1201 – 2400 | 6 |
| > 2400 | 8 |



[21] Cover cap for MUL striker, only in combination with MUL striker, screw-on.

|  |  | Nº |
|---|--|--------|
| R01.1 | Natural silver | 819632 |
| R05.3 | Medium bronze | 819631 |
| R06.2 | Jet black | 798979 |





| | | |
|---|---|---|
|  |  | Nº |
| R07.2 | Traffic white | 808054 |
|  | |  |
| ≤ 1200 | | 4 |
| 1201 – 2400 | | 6 |
| > 2400 | | 8 |

[*] Operating sequence control set  1
SRH ≥ 1200 mm, profile-related

| | | |
|---|---|--------|
|  |  | Nº |
| PVC | ASAŞ Inova | 858557 |

| | | |
|------------|---|----------|
| [*] |  | # |
| [42] | Cam with countersunk screw, M5 x 20 | 1 |
| [43] | Anti-lifting device | 1 |
| [44] | Striker with buffer | 1 |

[24] Pin for anti-pushback function  1

| | |
|---|--------|
|  | Nº |
| 34 | 822393 |

[25] Centre closer for anti-pushback function  1

| | | |
|---|---|--------|
|  |  | Nº |
| 41 | Left | 821687 |
| | Right | 823736 |



INFO

DIN L: order right components.
DIN R: order left components.

[26] Striker for anti-pushback function  1

| | |
|---|--------|
|  | Nº |
| Striker for anti-pushback function | 810279 |

[27] Cover cap for striker for anti-pushback function  1

| | | |
|---|---|--------|
|  |  | Nº |
| R01.1 | Natural silver | 828482 |
| R05.3 | Medium bronze | 828483 |
| R06.2 | Jet black | 809717 |
| R07.2 | Traffic white | 819351 |

[33] Stopper, cannot be used in conjunction with a control unit with SoftOpen / SoftClose together with SoftStop on the mullion side / SoftStop on the locking side.  2





| | |
|---|--------|
|  | Nº |
| Stopper | 800196 |

[34] Packer  2

| | |
|---|--------|
|  | Nº |
| Packer | 800197 |

Alternatively

[2b] VT espagnolette, lockable (alternative to 2a) → from page 146  1

| | | | | | | | |
|---|---|--|---|---|---|---|-----------------|
|  |  |  |  |  |  |  | Nº |
| 40 | 1801 – 2400 | 1890 | 200 | 1000 | 2 | V | Roto Sil 795603 |
| | 2401 – 2500 | 2290 | 200 | 1000 | 2 | V | Roto Sil 795604 |

[37] Rubber buffer (alternative to 33)  4

| | |
|---|--------|
|  | Nº |
| 14 | 729179 |

Optional

[33] Stopper, cannot be used in conjunction with a control unit with SoftOpen and SoftStop on the locking side.  1

| | |
|---|--------|
|  | Nº |
| Stopper | 800196 |

[34] Packer  1

| | |
|---|--------|
|  | Nº |
| Packer | 800197 |

[35] Brush holder

| | |
|---|--------|
|  | Nº |
| Brush holder | 809520 |

| | |
|---|---|
|  |  |
| < 1060 | 4 |
| ≥ 1060 | 6 |

[80] Tilt protection device; for application ranges SRH:SRW = > 2:1 up to max. 3:1; can only be used without control unit with Soft function.  4

| | |
|---|--------|
|  | Nº |
| Tilt protection device | 897049 |

4.2.8 Decco | 83 and 99

4.2.8.1 Diagram A

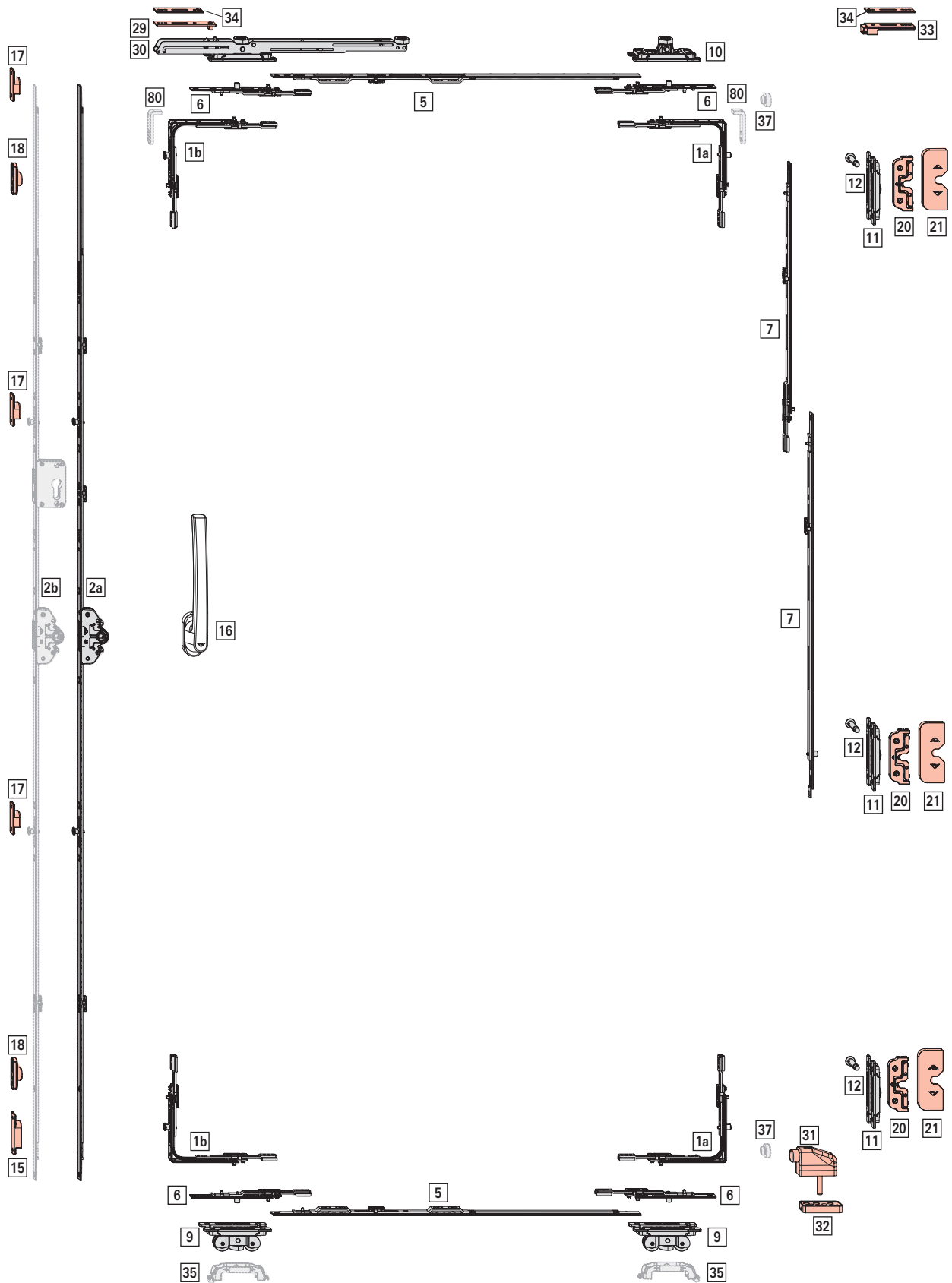



Application range

SRW: 710 – 2000 mm

SRH: 600 – 2500 mm

S.kg: max. 250 kg

| | | | |
|--------------------------|------------|--|---|
| [1a] Corner drive | With E cam | | 2 |
| [1b] | With V cam | | 2 |

| | | Nº |
|---|---|--------|
| 1 | E | 260275 |
| 1 | V | 260272 |

[2a] VT espagnolette

| | | | | | | | | Nº |
|----|-------------|------|-----|------|---|---|----------|--------|
| 35 | 600 – 800 | 690 | 200 | 263 | – | – | Roto Sil | 799045 |
| | 801 – 1000 | 890 | 200 | 413 | – | – | Roto Sil | 798027 |
| | 1001 – 1200 | 1090 | 200 | 513 | 1 | V | Roto Sil | 798028 |
| | 1201 – 1600 | 1290 | 200 | 563 | 1 | V | Roto Sil | 798030 |
| | 1601 – 1800 | 1690 | 200 | 563 | 1 | V | Roto Sil | 798031 |
| | 1801 – 2400 | 1890 | 200 | 1000 | 2 | V | Roto Sil | 798032 |
| | 2401 – 2500 | 2290 | 200 | 1000 | 2 | V | Roto Sil | 798033 |

Espagnolette extension, (SRH > 1401 mm; not sh.)

| | | | | Nº |
|-----|---|---|---|--------|
| 200 | Y | – | – | 308267 |
| 400 | Y | – | – | 297858 |

Size-specific combinations:

| | | | | Nº |
|-------------|--------|---|---|--------|
| ≤ 1400 | – | – | – | – |
| 1401 – 1600 | 200 KU | – | – | 308267 |
| 1601 – 2000 | – | – | – | – |
| 2001 – 2200 | 200 KU | – | – | 308267 |
| 2201 – 2400 | 400 KU | – | – | 297858 |
| 2401 – 2500 | 200 KU | – | – | 308267 |

Centre lock (CL)

[5] CL component, horizontal

| | | | Nº |
|------|---|---|--------|
| 200 | – | – | 308267 |
| 344 | 1 | V | 572665 |
| 480 | – | – | 245729 |
| 590 | – | – | 603442 |
| 790 | 1 | E | 603444 |
| 990 | 1 | E | 603447 |
| 1190 | 1 | E | 603462 |
| 1440 | 1 | E | 603466 |

Size-specific combinations:

| | | | | Nº |
|-------|-----|---|---|--------|
| ≤ 760 | 344 | 1 | V | 572665 |

| | | | | Nº |
|-------------|------|---|---|--------|
| 761 – 860 | 480 | – | – | 245729 |
| 861 – 1060 | 590 | – | – | 603442 |
| 1061 – 1260 | 790 | 1 | E | 603444 |
| 1261 – 1460 | 990 | 1 | E | 603447 |
| 1461 – 1660 | 1190 | 1 | E | 603462 |
| 1661 – 1910 | 1440 | 1 | E | 603466 |
| ≥ 1911 | 1440 | 1 | E | 603466 |
| | 200 | – | – | 308267 |

[6] Centre lock component 130, horizontal

| | | | | Nº |
|-----|---|---|---|--------|
| 130 | Y | 1 | E | 764350 |

[7] CL component, vertical, on the mullion

| | | | | Nº |
|-----|---|---|---|--------|
| 200 | Y | – | – | 308267 |
| | Y | 1 | E | 450821 |
| 400 | Y | – | – | 297858 |
| 600 | Y | 1 | E | 255282 |
| | N | 1 | E | 255281 |

Size-specific combinations:

| | | | | Nº |
|-------------|--------|---|---|--------|
| 1201 – 1800 | 600 | 1 | E | 255281 |
| 1801 – 2000 | 200 KU | – | – | 308267 |
| | 600 | 1 | E | 255281 |
| 2001 – 2200 | 400 KU | – | – | 297858 |
| | 600 | 1 | E | 255281 |
| 2201 – 2400 | 200 KU | 1 | E | 450821 |
| | 400 KU | – | – | 297858 |
| | 600 | 1 | E | 255281 |
| 2401 – 2500 | 200 KU | – | – | 308267 |
| | 600 KU | 1 | E | 255282 |
| | 200 KU | – | – | 308267 |
| | 600 | 1 | E | 255281 |

[9] Roller unit

| | | Nº |
|----|-------|--------|
| 41 | Left | 821686 |
| | Right | 823733 |

| | | Nº |
|--------|--|----|
| < 1060 | | 2 |
| ≥ 1060 | | 3 |

[10] Control unit, on the mullion side and in the centre

→ *from page 158*
Alternatively (on the mullion side):
Control unit set with Soft function (incl. activator) → *from page 158*

| | | Nº |
|----|-------|--------|
| 41 | Left | 821685 |
| | Right | 823730 |



[*] Control unit set with Soft function, on the locking side → *from page 158*  1
Alternatively:
[10] Control unit 

Contents:

| [*] |  | # |
|------|---|---|
| [29] | Activator | 1 |
| [30] | Control unit with Soft function | 1 |

[11] Centre closer

|  |  | Nº |
|---|---|--------|
| 41 | Left | 821687 |
| | Right | 823736 |

|  |  |
|---|---|
| ≤ 1200 | 2 |
| 1201 – 2400 | 3 |
| > 2400 | 4 |



[12] MUL locking cam

|  | Nº |
|---|--------|
| 37.5 | 836782 |

|  |  |
|---|---|
| ≤ 1200 | 2 |
| 1201 – 2400 | 3 |
| > 2400 | 4 |

[15] Striker to prevent incorrect operation  1

|  | Nº |
|---|--------|
| Striker to prevent incorrect operation | 822789 |

[16] Parallel Sliding and Tilt&Slide handle – interior handle (200 mm handle length)  1
Sliding door handle – exterior recessed grip (43 mm distance), not sh.  1

[17] Striker

|  | Nº |
|---|--------|
| Screw-on | 744579 |



|  |  |
|---|---|
| ≤ 1200 | 2 |
| 1201 – 2400 | 3 |
| > 2400 | 4 |

[18] Buffer  2

|  | Nº |
|---|--------|
| 14 | 635307 |

[20] MUL striker

|  | Nº |
|---|--------|
| Screw-on | 793493 |

|  |  |
|---|---|
| ≤ 1200 | 2 |
| 1201 – 2400 | 3 |
| > 2400 | 4 |

[21] Cover cap for MUL striker, only in combination with MUL striker, screw-on.

|  |  | Nº |
|---|--|--------|
| R01.1 | Natural silver | 819632 |
| R05.3 | Medium bronze | 819631 |
| R06.2 | Jet black | 798979 |
| R07.2 | Traffic white | 808054 |

|  |  |
|---|---|
| ≤ 1200 | 2 |
| 1201 – 2400 | 3 |
| > 2400 | 4 |

[33] Stopper, cannot be used in conjunction with a control unit with SoftOpen and SoftStop on the mullion side.  1









|  | Nº |
|---|--------|
| Stopper | 800196 |

[34] Packer; profile-related quantity ^[8]

|  | Nº |
|---|--------|
| Packer | 800197 |

Alternatively

[2b] VT espagnolette, lockable (alternative to 2a)  1

|  |  |  |  |  |  |  |  | Nº |
|---|---|---|---|---|---|---|---|--------|
| 35 | 1801 – 2400 | 1890 | 200 | 1000 | 2 | V | Roto Sil | 798034 |
| | 2401 – 2500 | 2290 | 200 | 1000 | 2 | V | Roto Sil | 798055 |

[37] Rubber buffer (alternative to 33)  2

|  | Nº |
|---|--------|
| 14 | 729179 |

[8] Only use the number of packers that is specified in the profile assessment.



Optional

[35] Brush holder



Nº

Brush holder 809520



< 1060 2

≥ 1060 3

[80] Tilt protection device; for application ranges SRH:SRW = > 2:1 up to max. 3:1; can only be used without control unit with Soft function.  2



Nº

Tilt protection device 897049

4.2.8.2 Diagram A – RC 2 / RC 2 N

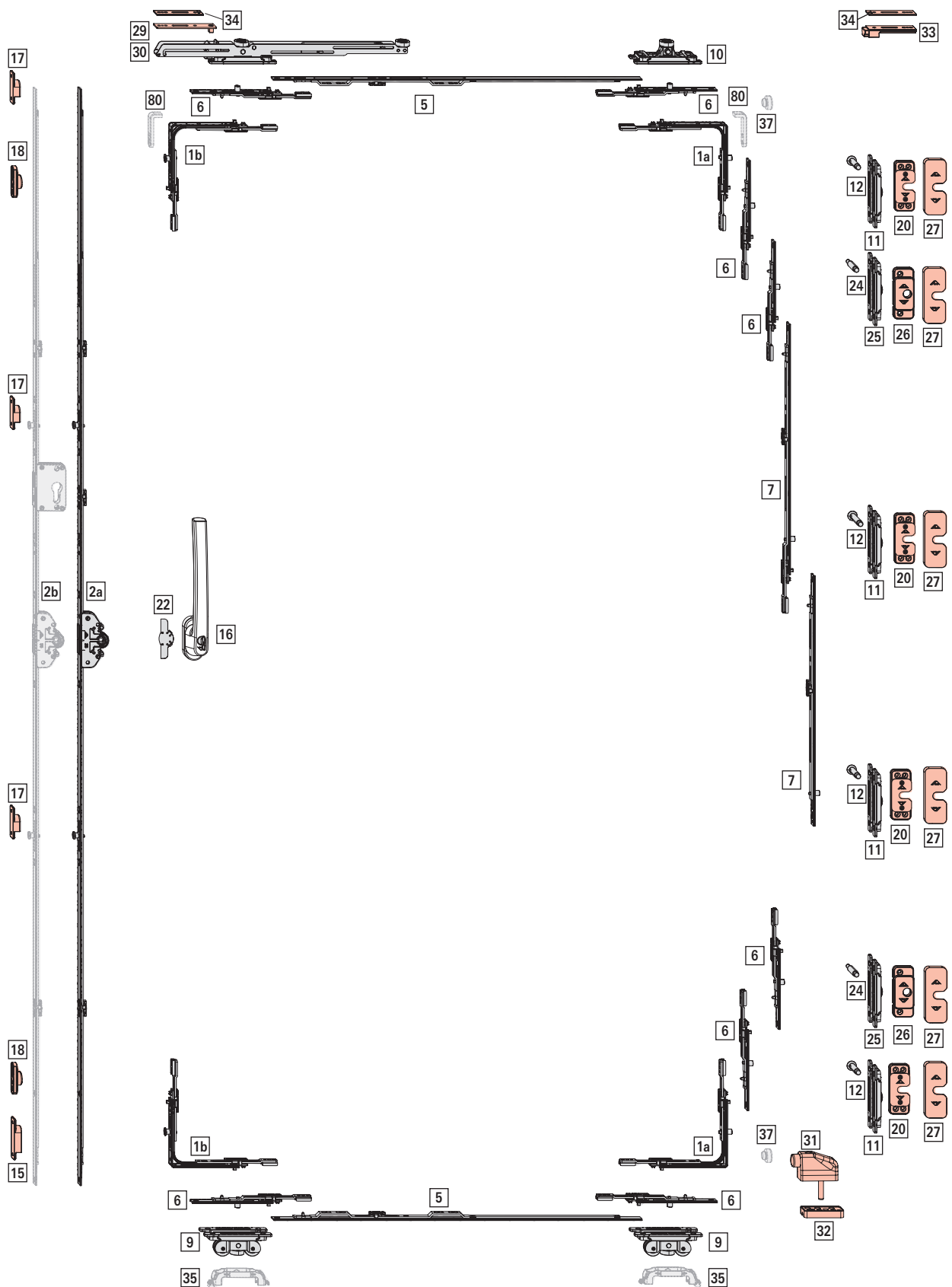



Application range

SRW: 710 – 2000 mm

SRH: 1072 – 2500 mm

S.kg: max. 200 kg

| | | | |
|--------------------------|------------|--|---|
| [1a] Corner drive | With E cam | | 2 |
| [1b] | With V cam | | 2 |

| | | Nº |
|---|---|--------|
| 1 | E | 260275 |
| 1 | V | 260272 |

[2a] VT espagnolette

| | | | | | | | | Nº |
|----|-------------|------|-----|------|---|---|----------|--------|
| 35 | 600 – 800 | 690 | 200 | 263 | – | – | Roto Sil | 799045 |
| | 801 – 1000 | 890 | 200 | 413 | – | – | Roto Sil | 798027 |
| | 1001 – 1200 | 1090 | 200 | 513 | 1 | V | Roto Sil | 798028 |
| | 1201 – 1600 | 1290 | 200 | 563 | 1 | V | Roto Sil | 798030 |
| | 1601 – 1800 | 1690 | 200 | 563 | 1 | V | Roto Sil | 798031 |
| | 1801 – 2400 | 1890 | 200 | 1000 | 2 | V | Roto Sil | 798032 |
| | 2401 – 2500 | 2290 | 200 | 1000 | 2 | V | Roto Sil | 798033 |

Espagnolette extension, (SRH > 1401 mm; not sh.)

| | | | | Nº |
|-----|---|---|---|--------|
| 200 | Y | – | – | 308267 |
| 400 | Y | – | – | 297858 |

Size-specific combinations:

| | | | | Nº |
|-------------|--------|---|---|--------|
| ≤ 1400 | – | – | – | – |
| 1401 – 1600 | 200 KU | – | – | 308267 |
| 1601 – 2000 | – | – | – | – |
| 2001 – 2200 | 200 KU | – | – | 308267 |
| 2201 – 2400 | 400 KU | – | – | 297858 |
| 2401 – 2500 | 200 KU | – | – | 308267 |

Centre lock (CL)

[5] CL component, horizontal

| | | | Nº |
|------|---|---|--------|
| 200 | – | – | 308267 |
| 344 | 1 | V | 572665 |
| 480 | – | – | 245729 |
| 590 | – | – | 603442 |
| 790 | 1 | E | 603444 |
| 990 | 1 | E | 603447 |
| 1190 | 1 | E | 603462 |
| 1440 | 1 | E | 603466 |

Size-specific combinations:

| | | | | Nº |
|-------|-----|---|---|--------|
| ≤ 760 | 344 | 1 | V | 572665 |

| | | | | Nº |
|-------------|------|---|---|--------|
| 761 – 860 | 480 | – | – | 245729 |
| 861 – 1060 | 590 | – | – | 603442 |
| 1061 – 1260 | 790 | 1 | E | 603444 |
| 1261 – 1460 | 990 | 1 | E | 603447 |
| 1461 – 1660 | 1190 | 1 | E | 603462 |
| 1661 – 1910 | 1440 | 1 | E | 603466 |
| ≥ 1911 | 1440 | 1 | E | 603466 |
| | 200 | – | – | 308267 |

[6] Centre lock component 130, horizontal

| | | | | Nº |
|-----|---|---|---|--------|
| 130 | Y | 1 | E | 764350 |

[7] CL component, vertical, on the mullion

| | | | | Nº |
|-----|---|---|---|--------|
| 200 | Y | – | – | 308267 |
| | Y | 1 | E | 450821 |
| 400 | Y | – | – | 297858 |
| 600 | Y | 1 | E | 255282 |
| | N | 1 | E | 255281 |

Size-specific combinations:

| | | | | Nº |
|-------------|--------|---|---|--------|
| 1201 – 1800 | 600 | 1 | E | 255281 |
| 1801 – 2000 | 200 KU | – | – | 308267 |
| | 600 | 1 | E | 255281 |
| 2001 – 2200 | 400 KU | – | – | 297858 |
| | 600 | 1 | E | 255281 |
| 2201 – 2400 | 200 KU | 1 | E | 450821 |
| | 400 KU | – | – | 297858 |
| | 600 | 1 | E | 255281 |
| 2401 – 2500 | 200 KU | – | – | 308267 |
| | 600 KU | 1 | E | 255282 |
| | 200 KU | – | – | 308267 |
| | 600 | 1 | E | 255281 |

[9] Roller unit

| | | Nº |
|----|-------|--------|
| 41 | Left | 821686 |
| | Right | 823733 |

| < 1060 | 2 |
|--------|---|
| ≥ 1060 | 3 |

[10] Control unit, on the mullion side and in the centre

→ *from page 158*
 Alternatively (on the mullion side):
 Control unit set with Soft function (incl. activator) → *from page 158*



| | | Nº |
|----|-------|--------|
| 41 | Left | 821686 |
| | Right | 823730 |



[*] Control unit set with Soft function, on the locking side → *from page 158*  1
Alternatively:
[10] Control unit

Contents:

| [*] |  | # |
|------|---|---|
| [29] | Activator | 1 |
| [30] | Control unit with Soft function | 1 |

[11] Centre closer



|  |  | Nº |
|---|---|--------|
| 41 | Left | 821687 |
| | Right | 823736 |

| | |
|-------------|---|
| ≤ 1072 | 2 |
| 1073 – 1700 | 3 |
| 1701 – 2100 | 4 |
| > 2100 | 5 |

[12] MUL locking cam



|  | Nº |
|--|--------|
| 37.5 | 836782 |

| | |
|-------------|---|
| ≤ 1072 | 2 |
| 1073 – 1700 | 3 |
| 1701 – 2100 | 4 |
| > 2100 | 5 |



[15] SEC striker to prevent incorrect operation  1

|  | Nº |
|---|--------|
| SEC striker to prevent incorrect operation | 822796 |

[16] Parallel Sliding and Tilt&Slide handle – interior handle, lockable (200 mm handle length)  1
Sliding door handle – exterior recessed grip (43 mm distance), not sh.  1

[17] SEC striker

|  | Nº |
|---|--------|
| Screw-on | 798226 |

 



| | |
|-------------|---|
| ≤ 1072 | 2 |
| 1073 – 1700 | 3 |
| 1701 – 2100 | 4 |
| > 2100 | 5 |

[18] Buffer  2

|  | Nº |
|---|--------|
| 14 | 635307 |



[20] SEC MUL striker



|  | Nº |
|---|--------|
| SEC MUL striker | 828318 |

| | |
|-------------|---|
| ≤ 1072 | 2 |
| 1073 – 1700 | 3 |
| 1701 – 2100 | 4 |
| > 2100 | 5 |

[27] Cover cap for SEC MUL striker

|  |  | Nº |
|---|--|--------|
| R01.1 | Natural silver | 858400 |
| R05.3 | Medium bronze | 858402 |
| R06.2 | Jet black | 858401 |
| R07.2 | Traffic white | 858338 |

 

| | |
|-------------|---|
| ≤ 1072 | 2 |
| 1073 – 1700 | 3 |
| 1701 – 2100 | 4 |
| > 2100 | 5 |

[22] Drilling protection  1

|  | Nº |
|---|--------|
| Drilling protection | 770965 |

[24] Pin for anti-pushback function  2

|  | Nº |
|---|--------|
| 38 | 820048 |

[25] Centre closer for anti-pushback function  2

|  |  | Nº |
|---|---|--------|
| 41 | Left | 821687 |
| | Right | 823736 |

INFO
DIN L: order right components.
DIN R: order left components.

[26] Striker for anti-pushback function  2

|  | Nº |
|---|--------|
| Striker for anti-pushback function | 810279 |

[27] Cover cap for striker for anti-pushback function  2

|  |  | Nº |
|---|--|--------|
| R01.1 | Natural silver | 828482 |
| R05.3 | Medium bronze | 828483 |
| R06.2 | Jet black | 809717 |
| R07.2 | Traffic white | 819351 |



[33] Stopper, cannot be used in conjunction with a control unit with SoftOpen and SoftStop on the mullion side.  1

 N^o

Stopper 800196

[34] Packer; profile-related quantity ^[9]

 N^o

Packer 800197

Alternatively

[2b] VT espagnolette, lockable (alternative to 2a)  1

 N^o

35 1801 – 2400 1890 200 1000 2 V Roto Sil 798034

2401 – 2500 2290 200 1000 2 V Roto Sil 798055

[37] Rubber buffer (alternative to 33)  2

 N^o

14 729179

Optional

[35] Brush holder

 N^o

Brush holder 809520

< 1060 2



≥ 1060 3

[80] Tilt protection device; for application ranges SRH:SRW = > 2:1 up to max. 3:1; can only be used without control unit with Soft function.  2

 N^o

Tilt protection device 897049

SKG info clip**, not sh.  1

    N^o

SKG** info clip For clipping onto the gearbox R07.2 Traffic white 331459

[9] Only use the number of packers that is specified in the profile assessment.

5 Espagnolettes

5.1 VT espagnolette

5.1.1 Backset 25, 30, 35, 40, 50 mm

Basic security



| | | | | | # | | | | Nº |
|----|-------------|------|-----|------|---|---|----------|--------|----|
| 25 | 600 – 800 | 690 | 200 | 263 | – | – | Roto Sil | 793942 | |
| | 801 – 1000 | 890 | 200 | 413 | – | – | Roto Sil | 793943 | |
| | 1001 – 1200 | 1090 | 200 | 513 | 1 | V | Roto Sil | 793944 | |
| | 1201 – 1600 | 1290 | 200 | 563 | 1 | V | Roto Sil | 793975 | |
| | 1601 – 1800 | 1690 | 200 | 563 | 1 | V | Roto Sil | 793977 | |
| | 1801 – 2400 | 1890 | 200 | 1000 | 2 | V | Roto Sil | 793978 | |
| | 2401 – 2500 | 2290 | 200 | 1000 | 2 | V | Roto Sil | 793980 | |
| 30 | 600 – 800 | 690 | 200 | 263 | – | – | Roto Sil | 785912 | |
| | 801 – 1000 | 890 | 200 | 413 | – | – | Roto Sil | 785913 | |
| | 1001 – 1200 | 1090 | 200 | 513 | 1 | V | Roto Sil | 785914 | |
| | 1201 – 1600 | 1290 | 200 | 563 | 1 | V | Roto Sil | 785915 | |
| | 1601 – 1800 | 1690 | 200 | 563 | 1 | V | Roto Sil | 785917 | |
| | 1801 – 2400 | 1890 | 200 | 1000 | 2 | V | Roto Sil | 785918 | |
| | 2401 – 2500 | 2290 | 200 | 1000 | 2 | V | Roto Sil | 785920 | |
| 35 | 600 – 800 | 690 | 200 | 263 | – | – | Roto Sil | 799045 | |
| | 801 – 1000 | 890 | 200 | 413 | – | – | Roto Sil | 798027 | |
| | 1001 – 1200 | 1090 | 200 | 513 | 1 | V | Roto Sil | 798028 | |
| | 1201 – 1600 | 1290 | 200 | 563 | 1 | V | Roto Sil | 798030 | |
| | 1601 – 1800 | 1690 | 200 | 563 | 1 | V | Roto Sil | 798031 | |
| | 1801 – 2400 | 1890 | 200 | 1000 | 2 | V | Roto Sil | 798032 | |
| | 2401 – 2500 | 2290 | 200 | 1000 | 2 | V | Roto Sil | 798033 | |
| 40 | 600 – 800 | 690 | 200 | 263 | – | – | Roto Sil | 792143 | |
| | 801 – 1000 | 890 | 200 | 413 | – | – | Roto Sil | 792144 | |
| | 1001 – 1200 | 1090 | 200 | 513 | 1 | V | Roto Sil | 792185 | |
| | 1201 – 1600 | 1290 | 200 | 563 | 1 | V | Roto Sil | 792188 | |
| | 1601 – 1800 | 1690 | 200 | 563 | 1 | V | Roto Sil | 792190 | |
| | 1801 – 2400 | 1890 | 200 | 1000 | 2 | V | Roto Sil | 792191 | |
| | 2401 – 2500 | 2290 | 200 | 1000 | 2 | V | Roto Sil | 792193 | |
| 50 | 600 – 800 | 690 | 200 | 263 | – | – | Roto Sil | 785921 | |
| | 801 – 1000 | 890 | 200 | 413 | – | – | Roto Sil | 785922 | |
| | 1001 – 1200 | 1090 | 200 | 513 | 1 | V | Roto Sil | 785923 | |
| | 1201 – 1600 | 1290 | 200 | 563 | 1 | V | Roto Sil | 785924 | |
| | 1601 – 1800 | 1690 | 200 | 563 | 1 | V | Roto Sil | 785926 | |
| | 1801 – 2400 | 1890 | 200 | 1000 | 2 | V | Roto Sil | 785927 | |
| | 2401 – 2500 | 2290 | 200 | 1000 | 2 | V | Roto Sil | 785929 | |



Lockable



| | | | | | | | | | Nº |
|----|-------------|------|-----|------|---|---|----------|--------|----|
| 25 | 1801 – 2400 | 1890 | 200 | 1000 | 2 | V | Roto Sil | 798285 | |
| | 2401 – 2500 | 2290 | 200 | 1000 | 2 | V | Roto Sil | 798286 | |
| 30 | 1801 – 2400 | 1890 | 200 | 1000 | 2 | V | Roto Sil | 798287 | |
| | 2401 – 2500 | 2290 | 200 | 1000 | 2 | V | Roto Sil | 798288 | |
| 35 | 1801 – 2400 | 1890 | 200 | 1000 | 2 | V | Roto Sil | 798034 | |
| | 2401 – 2500 | 2290 | 200 | 1000 | 2 | V | Roto Sil | 798055 | |
| 40 | 1801 – 2400 | 1890 | 200 | 1000 | 2 | V | Roto Sil | 795603 | |
| | 2401 – 2500 | 2290 | 200 | 1000 | 2 | V | Roto Sil | 795604 | |
| 50 | 1801 – 2400 | 1890 | 200 | 1000 | 2 | V | Roto Sil | 798218 | |
| | 2401 – 2500 | 2290 | 200 | 1000 | 2 | V | Roto Sil | 798219 | |

Second opening sash



| 25 | 600 – 800 | 690 | 200 | 263 | - | - | Roto Sil | 793942 |
|----|-------------|------|-----|------|---|---|----------|--------|
| | 801 – 1000 | 890 | 200 | 413 | - | - | Roto Sil | 793943 |
| | 1001 – 1200 | 1090 | 200 | 513 | - | - | Roto Sil | 809691 |
| | 1201 – 1600 | 1290 | 200 | 563 | - | - | Roto Sil | 809692 |
| | 1601 – 1800 | 1690 | 200 | 563 | - | - | Roto Sil | 809694 |
| | 1801 – 2400 | 1890 | 200 | 1000 | - | - | Roto Sil | 809695 |
| | 2401 – 2500 | 2290 | 200 | 1000 | - | - | Roto Sil | 809697 |
| 30 | 600 – 800 | 690 | 200 | 263 | - | - | Roto Sil | 785912 |
| | 801 – 1000 | 890 | 200 | 413 | - | - | Roto Sil | 785913 |
| | 1001 – 1200 | 1090 | 200 | 513 | - | - | Roto Sil | 809654 |
| | 1201 – 1600 | 1290 | 200 | 563 | - | - | Roto Sil | 809685 |
| | 1601 – 1800 | 1690 | 200 | 563 | - | - | Roto Sil | 809687 |
| | 1801 – 2400 | 1890 | 200 | 1000 | - | - | Roto Sil | 809688 |
| | 2401 – 2500 | 2290 | 200 | 1000 | - | - | Roto Sil | 809690 |
| 35 | 600 – 800 | 690 | 200 | 263 | - | - | Roto Sil | 799045 |
| | 801 – 1000 | 890 | 200 | 413 | - | - | Roto Sil | 798027 |
| | 1001 – 1200 | 1090 | 200 | 513 | - | - | Roto Sil | 809658 |
| | 1201 – 1600 | 1290 | 200 | 563 | - | - | Roto Sil | 809662 |
| | 1601 – 1800 | 1690 | 200 | 563 | - | - | Roto Sil | 809668 |
| | 1801 – 2400 | 1890 | 200 | 1000 | - | - | Roto Sil | 809669 |
| | 2401 – 2500 | 2290 | 200 | 1000 | - | - | Roto Sil | 809653 |
| 40 | 600 – 800 | 690 | 200 | 263 | - | - | Roto Sil | 792143 |
| | 801 – 1000 | 890 | 200 | 413 | - | - | Roto Sil | 792144 |
| | 1001 – 1200 | 1090 | 200 | 513 | - | - | Roto Sil | 809645 |
| | 1201 – 1600 | 1290 | 200 | 563 | - | - | Roto Sil | 809646 |
| | 1601 – 1800 | 1690 | 200 | 563 | - | - | Roto Sil | 809648 |
| | 1801 – 2400 | 1890 | 200 | 1000 | - | - | Roto Sil | 809649 |
| | 2401 – 2500 | 2290 | 200 | 1000 | - | - | Roto Sil | 809651 |
| 50 | 600 – 800 | 690 | 200 | 263 | - | - | Roto Sil | 785921 |
| | 801 – 1000 | 890 | 200 | 413 | - | - | Roto Sil | 785922 |
| | 1001 – 1200 | 1090 | 200 | 513 | - | - | Roto Sil | 809604 |
| | 1201 – 1600 | 1290 | 200 | 563 | - | - | Roto Sil | 809605 |
| | 1601 – 1800 | 1690 | 200 | 563 | - | - | Roto Sil | 809607 |
| | 1801 – 2400 | 1890 | 200 | 1000 | - | - | Roto Sil | 809608 |
| | 2401 – 2500 | 2290 | 200 | 1000 | - | - | Roto Sil | 809610 |



6 Jigs / tools

6.1 Drilling jigs

6.1.1 Roller unit / control unit

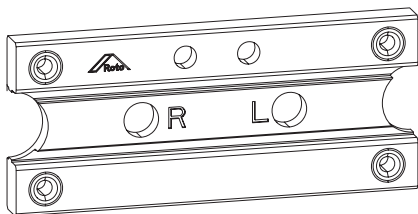

| | | | | N ^o |
|--------|------------|----------------------|----|----------------|
| Timber | - | - | 41 | 836948 |
| PVC | - | - | 41 | 836947 |
| | Salamander | evolutionDrive Plus+ | 41 | 2006575 |

6.1.2 Centre closer

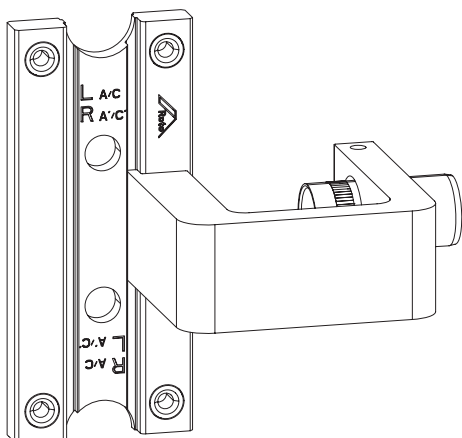

INFO

Use of a drilling jig with Ø 14.0 is mandatory for the centre closer, adjustable.

For centre closer: Ø 12.0

| | | | | N ^o |
|--------|------------|----------------------|----|----------------|
| Timber | - | - | 41 | 893971 |
| PVC | - | - | 41 | 893970 |
| | Salamander | evolutionDrive Plus+ | 41 | 2006576 |

For centre closer, adjustable: Ø 14.0

| | | | | N ^o |
|--------|---|---|----|----------------|
| Timber | - | - | 41 | 836943 |

|  |  |  |  | Nº |
|---|---|---|---|---------|
| PVC | - | - | 41 | 836942 |
| | Schüco | LivIng move | 41 | 2030459 |



6.1.3 Strikers

Mullion striker

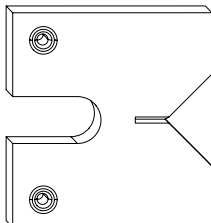

| | | | Nº |
|--------------------------|---|--------------------------|---------|
| |  | | |
| Aluplast smart-slide | | Fixed mullion MUL 140041 | 811973 |
| | | Fixed mullion MUL 140045 | 807972 |
| Aluplast smart-slide neo | | Fixed mullion MUL 160041 | 2027924 |
| | | Fixed mullion MUL 160043 | 2009993 |
| Gealan Smoovio | | Fixed mullion MUL 5862 | 809328 |
| Rehau | | Synego Slide | 836201 |
| Salamander | | evolutionDrive Plus+ | 897743 |
| Schüco | | Living move | 2006888 |
| ASAŞ | | Inova | 825052 |
| DECCO | | 83 | 2007236 |
| | | 99 | 2007219 |

Mullion security striker

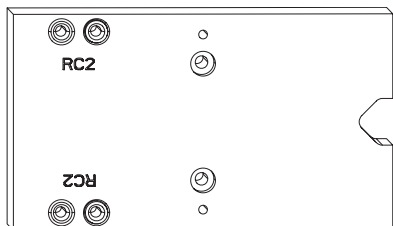

| | | |
|---|---|-----------|
|  |  | Nº |
| Aluplast smart-slide | Fixed mullion MUL 140045 | 834696 |
| Gealan Smoovio | Fixed mullion MUL 5862 | 834689 |

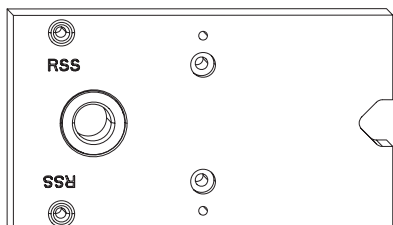

Striker for anti-pushback function

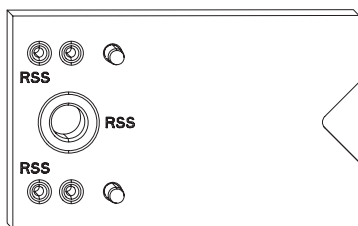

| | | |
|---|---|-----------|
|  |  | Nº |
| Aluplast smart-slide | Fixed mullion MUL 140045 | 834697 |
| Gealan Smoovio | Fixed mullion MUL 5862 | 834695 |

Mullion security striker and striker for anti-pushback function



| | | |
|---|---|-----------|
|  |  | Nº |
| Aluplast smart-slide neo | Fixed mullion MUL 160041 | 2027878 |
| Salamander | evolutionDrive Plus+ | 897744 |
| Schüco | Living move | 2006889 |
| DECCO | 83 | 2007237 |
| | 99 | 858844 |

Other jigs are available upon request.



6.1.4 Marker

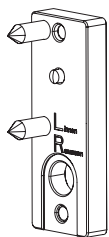

| | | | |
|--------------------------------------|---|---|----------------|
| | | | N ^o |
| Marker for striker T / PVC, screw-on | - | - | 772626 |

6.1.5 Drilling aid

For activator and stopper positioning jigs



| | |
|---|----------------|
| | N ^o |
| Drilling aid for roller track and guide track | 778521 |

6.1.6 Tilt protection device

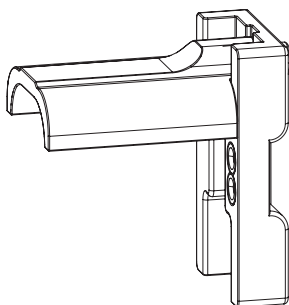

| | |
|-----|----------------|
| | N ^o |
| Top | 2000345 |

6.2 Positioning jigs

6.2.1 Activator

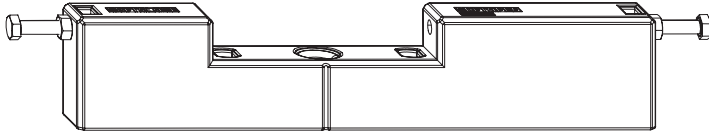

| | |
|--|----------------|
|  | N ^o |
| Drilling jig for activator | 2005536 |

6.2.2 Stopper

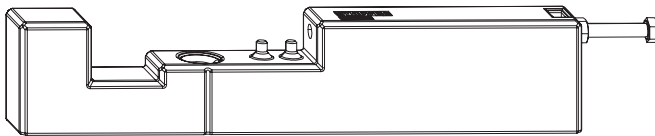

| | |
|--|----------------|
|  | N ^o |
| Drilling jig for stopper | 2005537 |

6.3 Tools

6.3.1 Hex keys

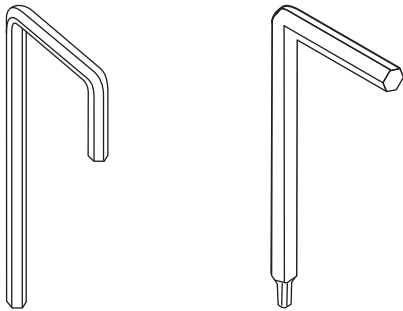

| | |
|--|----------------|
|  | N ^o |
| 4 mm hex key | 208609 |
| Hex key: 2.5 / 4.0 mm | 230764 |



6.3.2 Adjustment tools

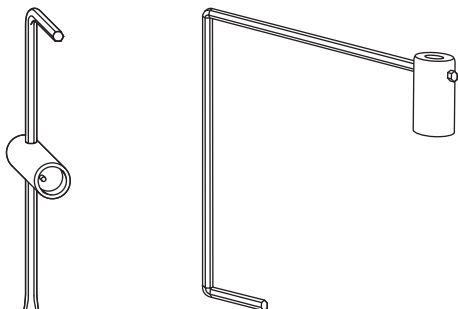

| | | |
|--------------------------------|--|------------------|
| | | Nº |
| Adjustment tool: V locking cam | | 258191 381574 |

6.3.3 Extractor handle

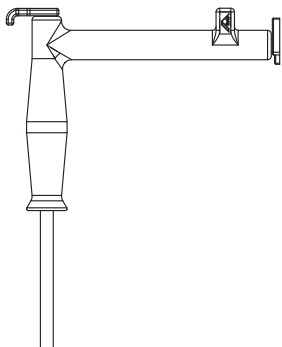

| | | |
|---------------------------------------|--|-----------|
| | | Nº |
| Extractor handle for stay-bearing pin | | 899630 |
| Replacement blade | | 230765 |

6.3.4 Tensioning tool

For control unit with soft function



| | | |
|-----------------|-------------------------------------|-----------|
| | | Nº |
| Tensioning tool | For control unit with soft function | 837763 |

6.3.5 Mitre pliers

For Deventer gaskets





| | | |
|---|---|-----------|
|  |  | Nº |
| Mitre pliers with integrated insertion roller | For cutting DEVENTER gaskets at a 90° angle | 798833 |

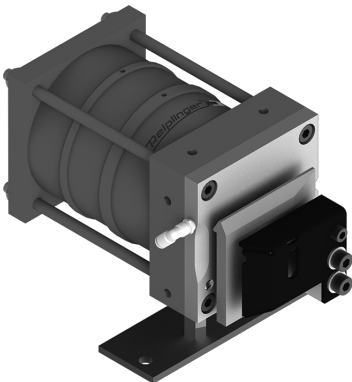

6.4 Punches

6.4.1 Pneumatic punch – PS 100



| | | | |
|---|---|---|-----------|
|  |  |  | Nº |
| Pneumatic punch – PS 100 | For offset cuts | Left | 553992 |
| | | Right | 553993 |

Accessories



| | | |
|---|---|-----------|
|  |  | Nº |
| Foot control for pneumatic punch | – | 554096 |
| Hand control for pneumatic punch | – | 554097 |

| | | |
|---|--|-----------|
|  |  | Nº |
| Ruler | Left | 230758 |
| | Right | 230759 |
| VT calliper | Left | 632972 |
| | Right | 632973 |





6.4.2 Hydropneumatic punch – DUO



| | | | |
|---|--|---|--------|
|  |  |  | Nº |
| Hydropneumatic punch – DUO | For offset cuts | Left | 262155 |
| | | Right | 262156 |

Accessories

| | | |
|---|---|--------|
|  |  | Nº |
| Foot control for hydropneumatic punch | – | 230760 |
| Hand control for hydropneumatic punch | – | 230761 |

| | | |
|---|--|--------|
|  |  | Nº |
| Ruler | Left | 230758 |
| | Right | 230759 |
| VT calliper | Left | 632972 |
| | Right | 632973 |

7 Accessories

7.1 Control unit with Soft function

Positioning options for the control unit

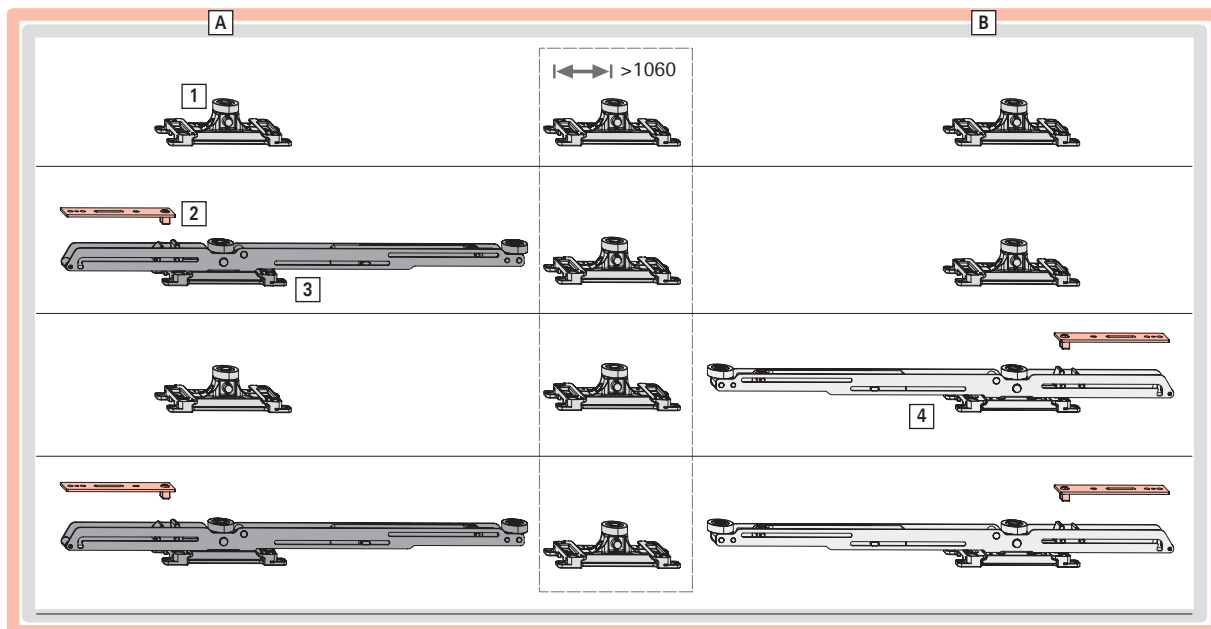

[A] On the locking side

[B] On the mullion side

[1] Control unit without Soft function

[2] Activator for control unit with Soft function

[3] Control unit with SoftClose

[4] Control unit with SoftOpen

| Control unit | Min. SRW | Alignment | Position | Function |
|-----------------------|--------------|--|---|--|
| Without Soft function | 710 | – | On the espagnolette side, on the mullion side | – |
| | 1060 | – | Centred | Supports the sash from SW > 1060 |
| With SoftClose | 710* / 920** | Additional control roller faces towards the centre of the sash | On the locking side | Damps the movement of the sash in the locking direction and draws it slowly closed. |
| With SoftOpen | 710* / 920** | Additional control roller faces towards the centre of the sash | On the mullion side | Damps the movement of the sash in the opening direction and draws it slowly into the final position. |

* Min. SW with one control unit with Soft function

** Min. SW with two control units with Soft function

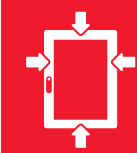

Control unit set with SoftClose (incl. activator)

SRW ≥ 710 mm

Installation position: at the top of the locking side



INFO

Also order an activator for an asymmetrical screw fixing:

- aluplast | smart-slide

| | | | | Nº |
|-------------------|--------|--------|--------|--------|
| Espagnolette side | 41 | 100 kg | Left | 837235 |
| | | | Right | 837152 |
| | 200 kg | Left | 837236 | |
| | | Right | 837153 | |

Control unit set with SoftOpen (incl. activator)

S.kg ≤ 200 kg

Installation position: at the top of the mullion side



INFO

Also order an activator for an asymmetrical screw fixing:

- aluplast | smart-slide

| | | | | Nº |
|--------------|--------|--------|--------|--------|
| Mullion side | 41 | 100 kg | Left | 838569 |
| | | | Right | 838566 |
| | 200 kg | Left | 838570 | |
| | | Right | 838567 | |

7.2 Activator spare part for control unit with soft function

The activator for a centre screw fixing is included in the control unit set.



INFO

Also order an activator for an asymmetrical screw fixing:

- aluplast | smart-slide

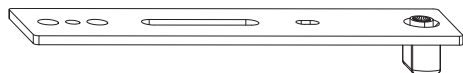

| | | Nº |
|-----------------------------|--|--------|
| Activator for soft function | Can be used with a centre screw fixing | 837318 |

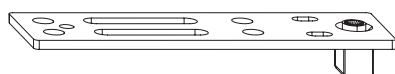

| | | Nº |
|-----------------------------|---|---------|
| Activator for soft function | Can be used with an asymmetrical screw fixing | 2027528 |

7.3 Rubber buffer

Diagram C: cannot be used in conjunction with SoftOpen or SoftStop on the mullion side.

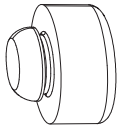

| | |
|---|-----------|
|  | Nº |
| 16.5 | 780647 |
| 17.5 | 798249 |

7.4 Label

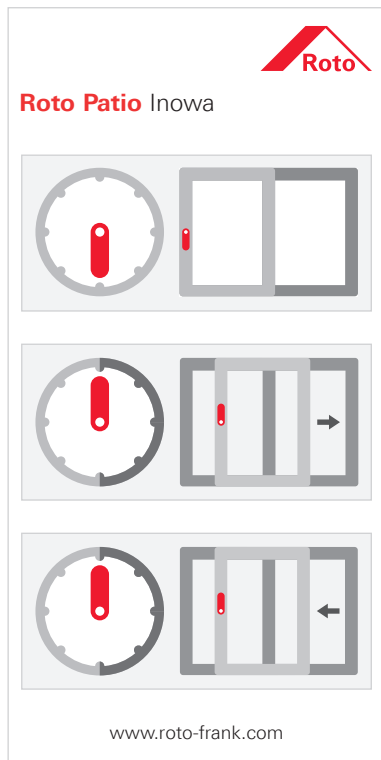

| | |
|---|-----------|
|  | Nº |
| Label indicating the operating sequence, diagram A | 811486 |

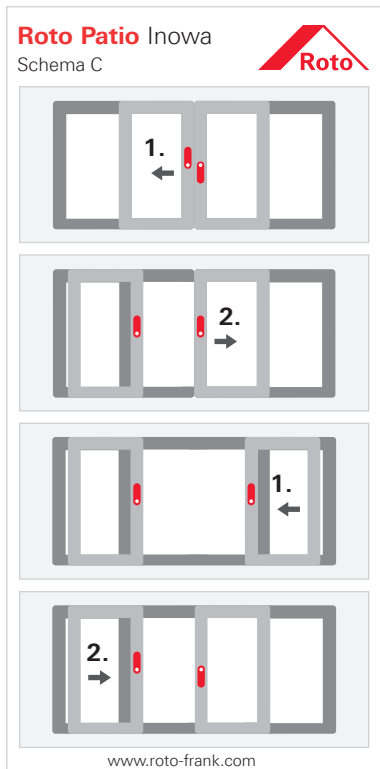



Fig. 7.1: Figure for installation DIN right

| | | |
|--|---|----------------------|
|  |  | N^o |
| Label indicating the operating sequence, diagram C | Left | 823251 |
| | Right | 823250 |

8 Brief instructions

8.1 Diagram A, A', K, K'

Summary of IMO 403

| | Installation sequence | Note | Page reference | Timber | PVC |
|-----------------------------------|--|---|-----------------|--------|-----|
| Sash | Crop the hardware components. | | → from page 171 | ■ | ■ |
| | Install the adapter profile. | Only applicable to Salamander evolutionDrive Plus+ and Schüco Living move. | → from page 172 | | ■ |
| | Install the corner drives. | Align the cam vertically. | → from page 175 | ■ | ■ |
| | Install the centre lock, vertical on the locking side. | Size-dependent | | ■ | ■ |
| | Install the espagnolette. | Insert with the arrow pointing up. | → from page 176 | ■ | ■ |
| | Install the centre locks. | CL 130, horizontal at the top and bottom. Horizontal at the top and bottom (size-dependent). Vertical on the mullion side (size-dependent). | → from page 176 | ■ | ■ |
| | Install the handle. | | → from page 177 | ■ | ■ |
| | Install the roller unit. | Timber: must not be pushed into the timber. Adapt the insertion torque if necessary. | | ■ | ■ |
| | Install the control unit. | Alternatively: Install the control unit with Soft function → from page 158. Timber: must not be pushed into the timber. Adapt the insertion torque if necessary. | | ■ | ■ |
| | Install the centre closer with mullion locking cam. | Timber: must not be pushed into the timber. Adapt the insertion torque if necessary. | | ■ | ■ |
| Frame | Install the adapter profile. | Only applicable to Salamander evolutionDrive Plus+ and Schüco Living move. | → from page 204 | | ■ |
| | Install strikers. | Note the point of entry. | → from page 209 | ■ | ■ |
| | Install the striker to prevent incorrect operation. | | → from page 217 | ■ | ■ |
| | Install the roller track. | Length: FIW - 2 | | ■ | ■ |
| | Install the operator track. | Length: (FIW - 2) / 2 Screw down in the access area. | → from page 201 | ■ | ■ |
| Install the gasket pad. | Only applicable to Salamander evolutionDrive Plus+. | → from page 205 | | ■ | |
| Joining the sash and frame | Install the operator track. | Length: (FIW - 2) / 2 Screw down in the fixed glazing area. | → from page 201 | ■ | ■ |
| | Place the sash on the roller track. | Move the handle to the sliding position. | | ■ | ■ |
| | Install the mullion strikers. | | → from page 219 | ■ | ■ |
| | Install the activator. | Only with control unit with Soft function. | → from page 223 | ■ | ■ |
| | Install the control unit with Soft function. | | → from page 180 | ■ | ■ |
| | Installing the tilt protection device | For application ranges SRH:SRW = > 2:1 up to max. 3:1; can only be used without control unit with Soft function. | → from page 229 | | ■ |
| | Install the stop. | | | ■ | ■ |
| | Install the end stop with packer. | | → from page 231 | ■ | ■ |
| Final acceptance | Install the element. | Place supports under the threshold every 300 mm across its entire area. Max. permitted unevenness of the entire threshold: 3 mm. We recommended that you place supports under the threshold across its entire area. | → from page 236 | ■ | ■ |
| | Adjust the hardware. | | → from page 241 | ■ | ■ |
| | Lubricate the hardware. | | → from page 247 | ■ | ■ |
| | Check the handle operating torque. | Operating torque ≤ 10 Nm | | ■ | ■ |



9 Installation

9.1 Processing instructions

Maximum sash sizes and weights

The specifications, application diagrams and component assignments which can be found in the hardware manufacturer's product-specific documents provide information on the maximum permitted sash sizes and weights. The component with the lowest permitted load bearing capacity determines the maximum permitted sash weight.

- Before using electronic data records and implementing them in window fabrication programs in particular, check that they match the specifications, application diagrams and component assignments.
- Never exceed the maximum permitted sash sizes and weights. If any points are unclear, contact the hardware manufacturer.

Specifications from profile manufacturers

The element manufacturer must comply with all specified system dimensions (e.g. gasket gap dimensions or locking distances).

They must continue to ensure and check this on a regular basis, especially when new hardware components are used for the first time, during production and on a continuous basis, up to and including element installation.



INFO

The hardware components are always designed in such a way that any system dimensions affected by the hardware can be adjusted. The hardware manufacturer shall not be liable for any additional expenses incurred if a deviation from these dimensions is not discovered until after the element has been installed.

Combining hardware

Burglar-inhibiting elements need hardware which meets special requirements.

Elements for wet rooms and those for use in environments with aggressive, corrosive constituents in the air require hardware that meets special requirements.

The resistance of elements to wind loads when they are closed and locked depends on the individual design of the element. The hardware system is capable of handling wind loads specified by legislation and standards (for example in accordance with EN 12210 – especially test pressure P3).

Coordinate suitable hardware combinations and installation procedures in elements with the hardware manufacturer and profile manufacturer for the areas listed above, and conclude a separate agreement for them.



INFO

The hardware manufacturer's specifications on the combination of hardware (e.g. the use of additional scissor stays, the design of hardware for burglar-inhibiting elements, etc.) are binding.

Installation surfaces

The frame and sash grooves must be free from construction materials (such as plaster, gypsum). The sash groove must be free from welding residue to ensure an optimum supporting surface for the hardware components.

Specifications relating to installation and care



ATTENTION

Sealing compounds that contain silicone may cause property damage.

Sealing compounds that contain silicone may considerably reduce the sealing effect near the threshold after three to five years.

- ▶ Only use silicone-free sealing compounds to seal the threshold.

Remove excess sealing compound after installation.



ATTENTION

Using incorrect cleaning agents and sealing compounds may cause property damage.

Cleaning agents and sealing compounds may damage the surfaces of components and gaskets.

- ▶ Do not use aggressive or flammable liquids, acidic cleaners or abrasive cleaners.
- ▶ Only use mild, pH-neutral cleaning agents that have been diluted.
- ▶ Apply a thin protective film to the components, for example using a cloth soaked in oil.
- ▶ Avoid aggressive vapours (e.g. produced by formic acid, acetic acid, ammonia, amine compounds, ammonia compounds, aldehyde, carboric acid, chlorine, tannic acid) around the element.
- ▶ Do not use any acetic acid-crosslinking or acid-crosslinking sealing compounds or those with the aforementioned constituents as both direct contact with the sealing compound and its fumes can corrode the surface of the components.

9.2 Screw connections



DANGER

Incorrectly installed or screwed-in hardware components present a risk of death.

Incorrectly installed and screwed-in hardware components may lead to hazardous situations and cause serious or fatal accidents.

- ▶ During installation and screwdriving work, observe the specifications provided by the profile manufacturer; contact the profile manufacturer if necessary.
- ▶ Use the recommended screws.
- ▶ Select the length of the screws according to the profiles used.
- ▶ Ensure that the hardware components are adequately secured; contact the screw manufacturer if necessary.



ATTENTION

Using incorrect screw material may cause property damage.

Using the wrong screws may damage the components.

- ▶ Only use galvanised zinc-plated and passivated steel screws.
- ▶ Use screws with additional sealing in more challenging climatic conditions.
- ▶ Use stainless-steel screws on stainless-steel components only.
- ▶ For aluminium components, use screws made of steel (coated with zinc-nickel or zinc flakes) or stainless steel.



ATTENTION

Improper screw fixings may cause property damage.

Improper screw fixings may damage the components and the element as a whole, and stop them from working properly.

- ▶ Unless stated otherwise, turn screws in straight.
- ▶ Tighten screw heads until they are flush with the surface.
- ▶ Do not over-tighten screws. Note the torque. Choose a torque that will not deform the hardware and profile. Define profile-specific torques on the basis of the demo assembly.
- ▶ Use the recommended screws.
- ▶ Select the length of the screws according to the profiles used.



9.2.1 Overview



WARNING

Incorrect screw connections may pose a risk of death!

Hardware components can be pulled out of the sash if they are not screwed through a profile wall that is at least 6 mm thick in total or screwed down using rivet nuts.

- ▶ Select the length of the screws so that they will hold in the aluminium profile. Alternatively, insert additional aluminium profiles.



WARNING

Incorrect screw connections may pose a risk of death!

Short screws will not reach the steel reinforcement and will therefore not hold.

Hardware components can be pulled out of the sash if they are not screwed into the steel reinforcement.

- ▶ Select the length of the screws so that they will hold in the steel reinforcement.

Timber

| Components | Quantity | Size | Diameter to be drilled | Drive |
|--|----------|-------------------|------------------------|---------------|
| Corner drive | 2 | ST4.0 x ... | 3.0 | Not specified |
| Espagnolette / centre locks | ... | ST4.0 x ... | 3.0 | Not specified |
| Roller unit | 4 | ST4.0 x ... | 3.0 | Not specified |
| Control unit | 4 | ST4.0 x ... | 3.0 | Not specified |
| Centre closer | 4 | ST4.0 x ... | 3.0 | Not specified |
| Mullion striker / striker for anti-pushback function | 2 | ST4.0 x ... | 3.0 | Not specified |
| Striker / buffer | 2 | ST4.0 x ... | 3.0 | Not specified |
| Roller track / operator track | ... | ST3.9 – 4.0 x ... | 3.0 | Not specified |
| Activator / stopper | 3 | ST4.0 x ... | 3.0 | Not specified |
| Tilt protection device | 2 | ST4.0 x ... | 3.0 | Not specified |
| Roto Line handle | 2 | M5 x ... | 10.0 / 12.0 | Cross-head |

PVC

| Components | Quantity | Size | Diameter to be drilled | Drive |
|--|----------|---|------------------------------------|---------------|
| Corner drive | 2 | ST3.9 – 4.1 x ... | 3.5 | Not specified |
| Espagnolette / centre locks | ... | ST3.9 – 4.1 x ... | 3.5 | Not specified |
| Roller unit | 4 | ST3.9 – 4.1 x ... | 3.5 | Not specified |
| Control unit | 4 | ST3.9 – 4.1 x ... | 3.5 | Not specified |
| Centre closer | 4 | ST3.9 – 4.1 x ... | 3.5 | Not specified |
| Mullion striker / striker for anti-pushback function | 2 | ST3.9 – 4.1 x ... | 3.5 | Not specified |
| Striker / buffer | 2 | ST3.9 – 4.1 x ... Only applicable to Salamander evolutionDrive Plus+: ST3.5 – 4.2 x 15 – 25 ... | 3.0 – 3.5 (depending on the screw) | Not specified |
| SEC striker | 2 | ST3.9 – 4.1 x ... | 3.5 | Not specified |
| Roller track / operator track | ... | ST3.5 – 3.9 x ... | 3.0 | Not specified |
| Sash adapter profile | ... | ST4.2 x 30 | 3.5 | Not specified |
| Activator / stopper | 3 | ST3.9 – 4.1 x ... | 3.5 | Not specified |
| Tilt protection device | 2 | ST3.9 – 4.1 x ... | 3.5 | Not specified |
| Roto Line handle | 2 | M5 x ... | 10.0 / 12.0 | Cross-head |

Specifications for selecting screws

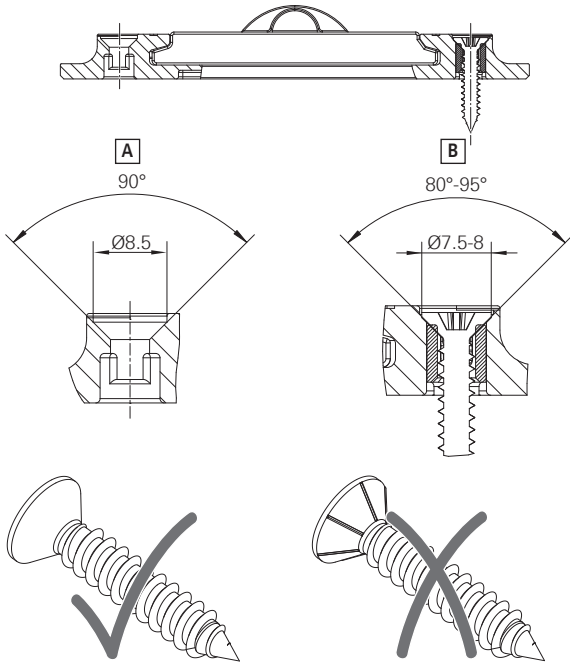

- [A] Specifications relating to the countersink
- [B] Specifications relating to the screw head for selecting screws



INFO

Routing grooves or V-shaped grooves may damage the fixing when screwing it in and prevent it from releasing.

9.3 Drilling and routing dimensions

9.3.1 VT espagnolette

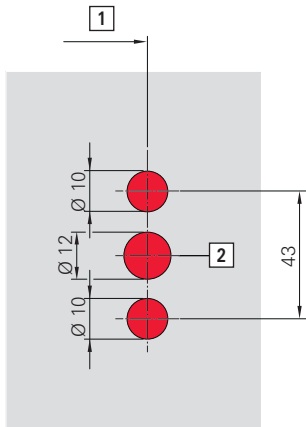

Drill holes for the handle's sprocket and lugs

- [1] Backset
- [2] Handle height

Drilling depth = overlap height + 16 (for countersunk screws in accordance with ISO 7046-1 M5 x ...)

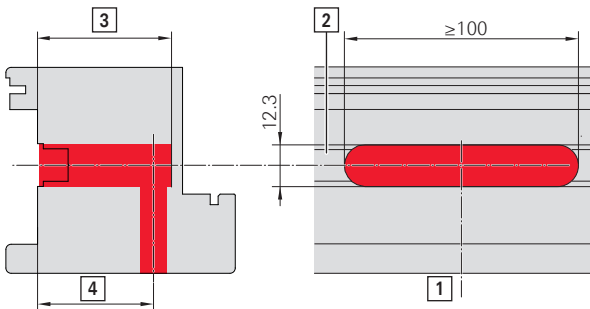

Gearbox routing

- [1] Centre of gearbox
- [2] Hardware groove
- [3] Gearbox routing depth:
BS + 17 (e.g. 30 + 17 = 47 mm)
- [4] Backset (BS)



9.3.2 VT espagnolette, lockable

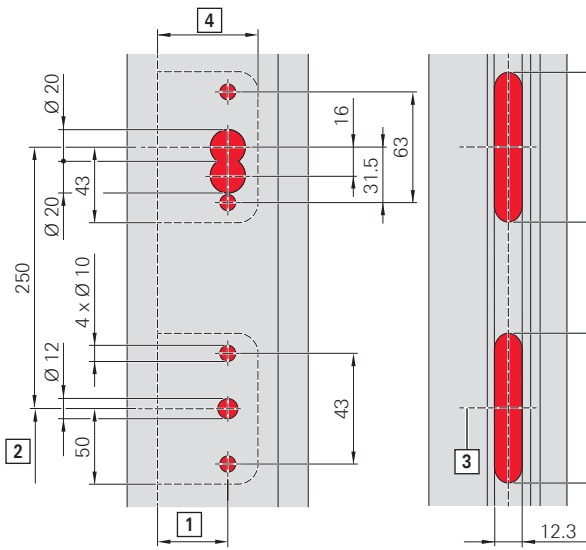

Drill holes for Roto Line handle and profile cylinder for lockable espagnolettes

- [1] Backset
- [2] Handle height
- [3] Centre of gearbox
- [4] Min. routing depth

Drill holes: at the bottom for the square spindle and handle mount, at the top for the profile cylinder and profile cylinder escutcheon mount

Routing for gearbox and lock casing

Routing: at the bottom for the gearbox, at the top for the lock casing

Gearbox / lock casing routing depth:

BS 25 = 42 mm

BS 30 = 47 mm

9.3.3 External recessed grip

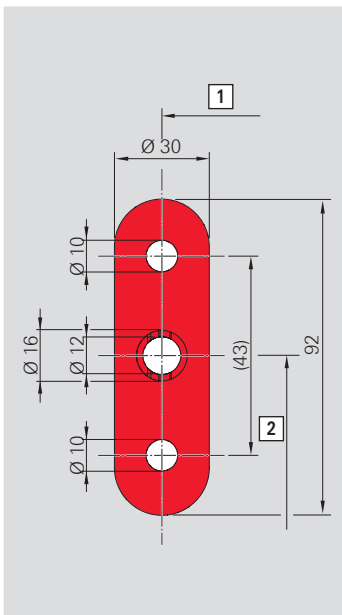

Recessed grip routing

Routing depth = 10 mm

- [1] Backset
- [2] Handle height

9.3.4 Diagram C – cam operating sequence control

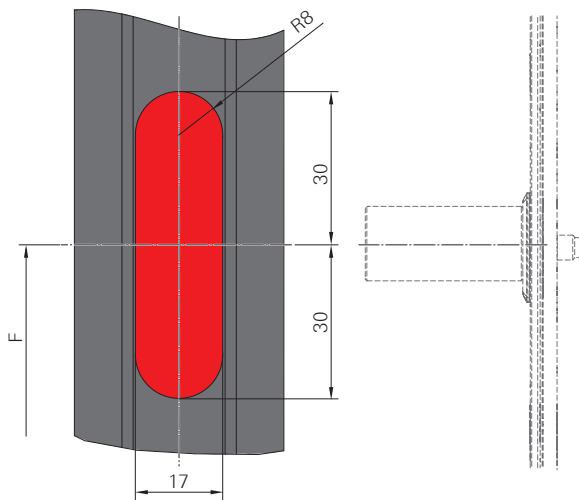
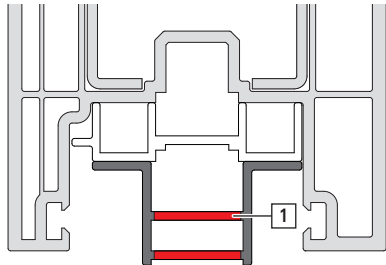

Routing for cam

Routing depth = through adapter profile [1]

F = Operating sequence control cam in open sliding position → 9.5.14 "Components in the floating mullion" from page 191

9.3.5 Striker H, can be routed in

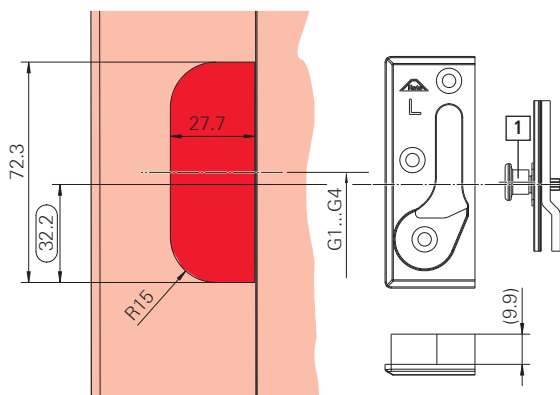

Routing for striker H, can be routed in

Routing depth = 10 mm

[1] Cam (VT espagnolette)



9.3.6 Rubber buffer

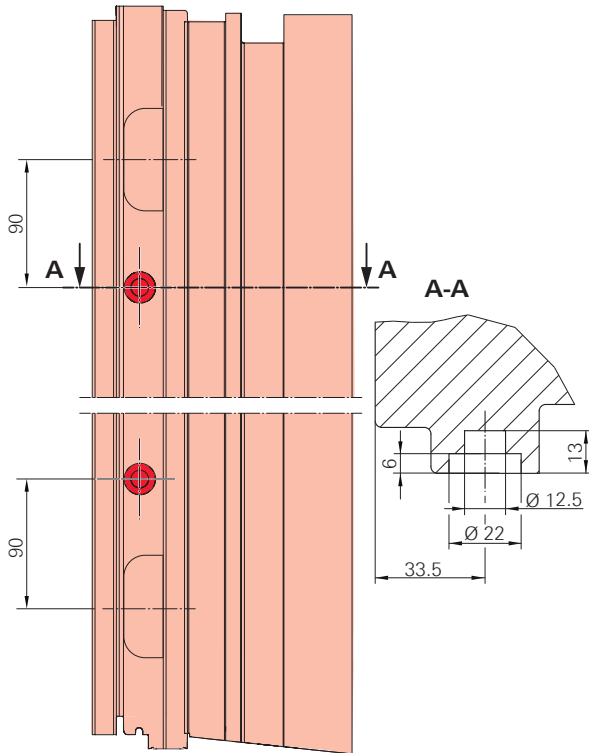

Create a stepped hole with a spade drill.

1. Drill to a depth of 6 mm with $\varnothing 22$ mm.
2. Drill to a depth of 13 mm with $\varnothing 12.5$ mm.

9.3.7 Tilt protection device

Notching the adapter profile

⇒ The adapter profile has just been cropped (length = frame external height - 158).

1. Notch the adapter profile (if present) at the top right and left of the sash in the area of the corner drive.

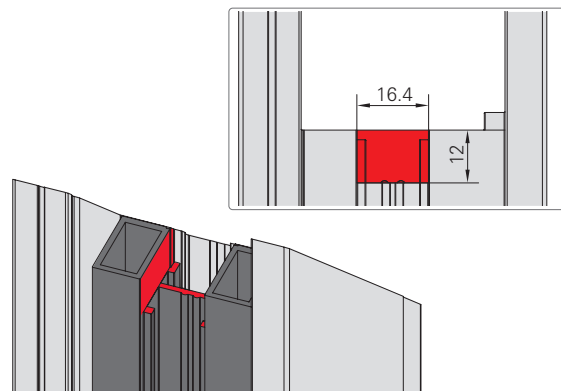

9.4 Force-fit connection

Coupleable hardware components always require a force-fit connection.

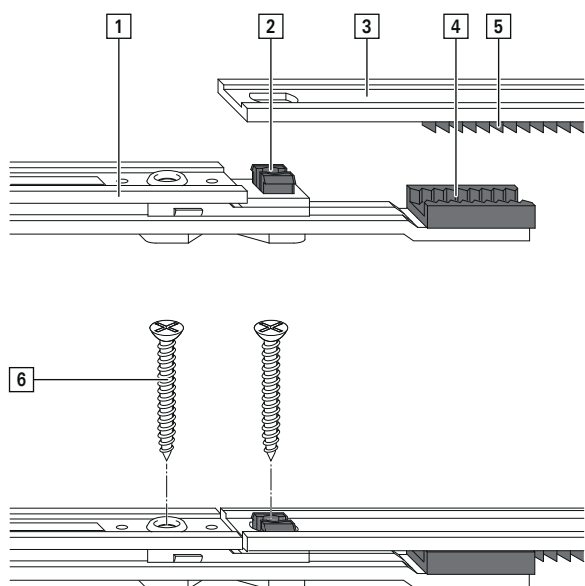

| Assignment | Description |
|------------|-----------------------------|
| [1] | Component A |
| [2] | Screw guide with clamp |
| [3] | Component B |
| [4] | Component A toothed segment |
| [5] | Component B toothed segment |
| [6] | Screw |

Force-fit connections are formed by screwing down components A and B so that forces and movements are transferred without loss.



INFO

All coupleable components are delivered attached in the centre.



9.5 Sash

9.5.1 Cropping the hardware components



ATTENTION

Incorrect cropping methods may result in property damage.

Do not insert the hardware components into the sash before they have been cropped. The screw guide engages and can be destroyed when it is removed.

- ▶ Only lay out the hardware components and do not insert them into the sash before they have been cropped.

The following hardware components are cropped:

- Espagnolette
- Centre locks

Cropping with a pneumatic punch (hole punching)

Hardware components are delivered 10 mm longer than the nominal dimension.

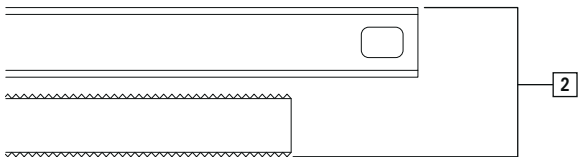
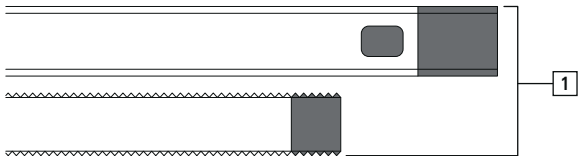

| Assignment | Description |
|------------|-------------------------|
| [1] | Hardware delivery state |
| [2] | Hardware, cropped |

1. Place the hardware component in the required position.
2. Mark the length on the hardware component.
3. Insert the hardware component [1] into the pneumatic punch [2].

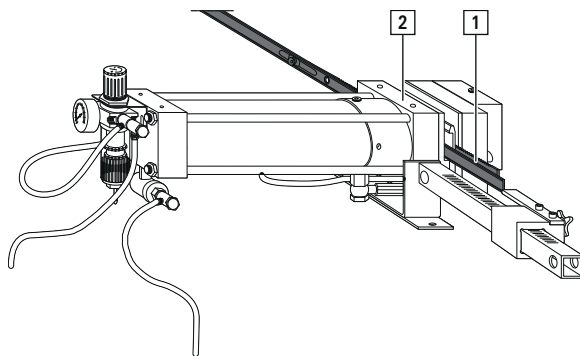

4. Align the hardware component.
5. Crop the hardware component.

9.5.2 Sash adapter profile

Only applicable to Salamander | evolutionDrive Plus+ and Schüco | Living move

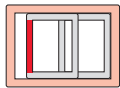

Preparing the adapter profile

1. Crop the adapter profile [1] at a 45° angle (alternatively: notch the adapter profile → 169).
 - Salamander | evolutionDrive Plus+: X = FEH - 158
 - Schüco | Living move: X = FEH - 170
- Predrill and countersink the adapter profile on both outer notches [2].
Drill: Ø 4.5

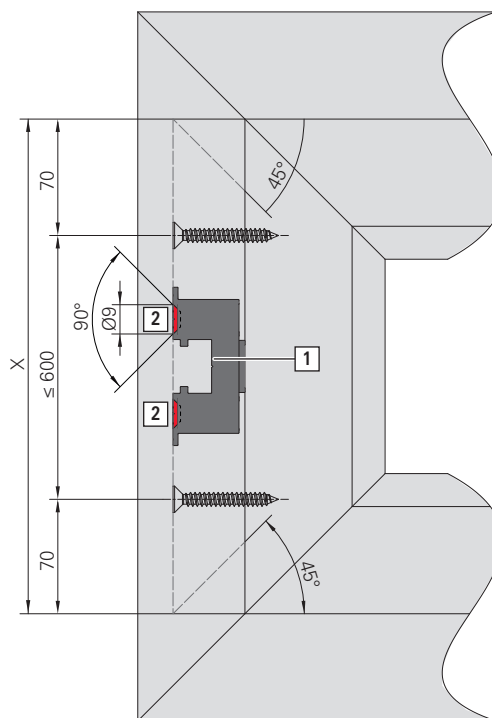

Preparing the adapter profile

1. Crop the adapter profile [1] at a 45° angle.
Predrill and countersink the adapter profile on both outer notches [2].
Drill: Ø 4.5

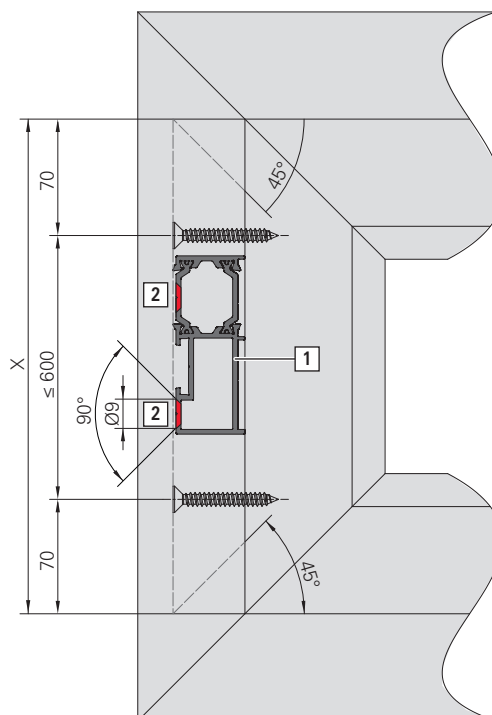



Installing the adapter profile

1. Place the adapter profile in the centre of the sash groove.
Align the adapter profile so that it is parallel with the sash groove.
Fasten the adapter profile in all predrilled holes using screws [1].

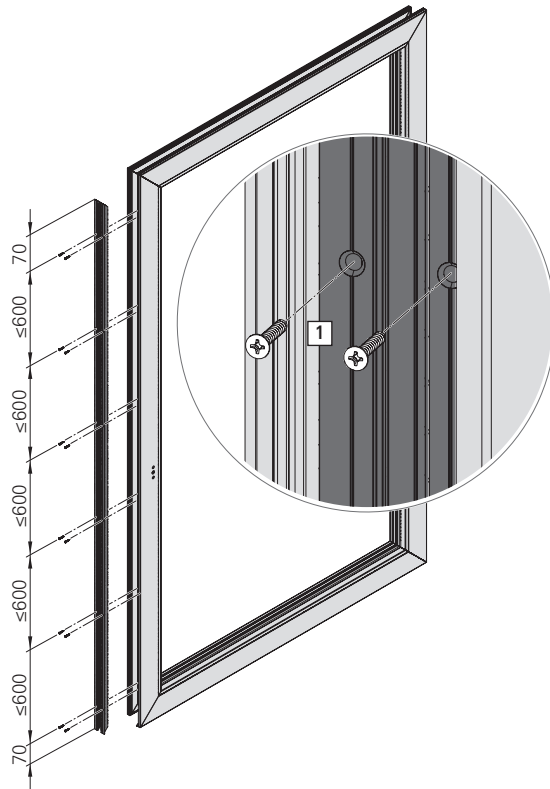

9.5.3 Installation sequence

9.5.3.1 Diagram A

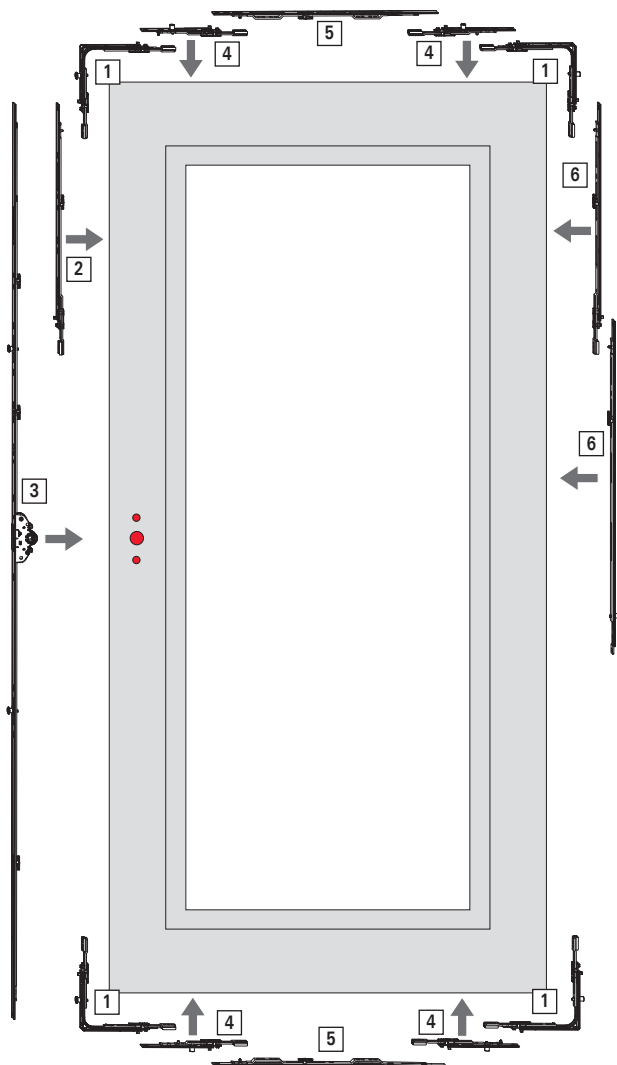

- [1] Corner drives
- [2] Centre lock, vertical on the locking side (size-dependent)
- [3] Espagnolette
- [4] Centre locks CL 130, horizontal at the top and bottom
- [5] Centre locks, horizontal at the top and bottom (size-dependent)
- [6] Centre locks, vertical on the mullion (size-dependent)



INFO

After installation, break the centre fixing on the espagnolette by turning the handle 180°. Turn the handle to the open sliding position.



9.5.4 Corner drive

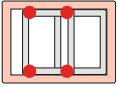

Installing the corner drive

1. Insert the corner drive with vertical cam position [1] and secure with two screws [2].

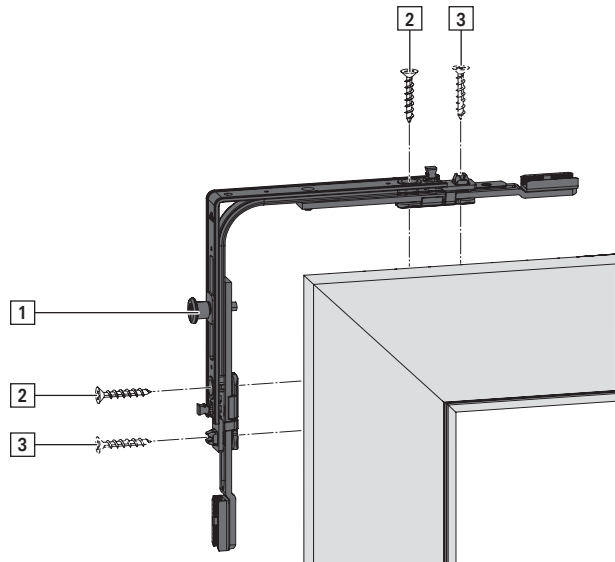

2. After all of the connector components have been installed, screw down the corner drives with a further two screws [3]. → 9.4 "Force-fit connection" from page 170



INFO

Diagram C / C' – second opening sash: insert the corner drives (with E cam) horizontally on the locking side with cam position and secure with screws.

9.5.5 Centre locks

9.5.5.1 Centre lock, vertical

Installing the centre lock, vertical

1. Place the centre lock in the required position on the mullion and espagnolette side, mark the length on one side, remove it and crop it. → 9.5.1 "Cropping the hardware components" from page 171
2. Insert the centre lock with the cropped side facing downwards and create a force-fit connection. → 9.4 "Force-fit connection" from page 170

9.5.5.2 Centre lock, horizontal

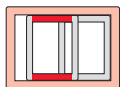

Installing the centre lock, horizontal

1. Place the centre lock at the bottom on the mullion side and at the top on the locking side, mark the length on one side, remove it and crop it → 9.5.1 "Cropping the hardware components" from page 171.
2. Insert the centre locks and create a force-fit connection → 9.4 "Force-fit connection" from page 170.

9.5.6 VT espagnolette

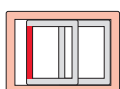

Installing the VT espagnolette

1. Place the espagnolette in the required position, mark the length on one side, remove and crop → 9.5.1 "Cropping the hardware components" from page 171.
2. Insert the espagnolette.
Create a force-fit connection → 9.4 "Force-fit connection" from page 170.

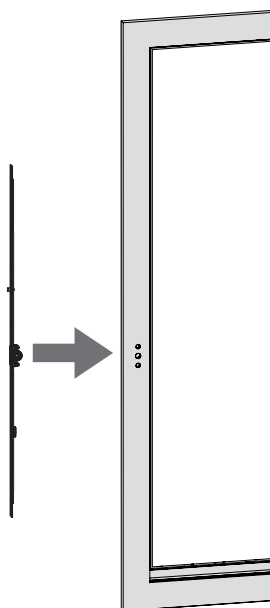



9.5.7 Handle and recessed grip

Installing the handle and recessed grip

1. Move the handle [1] to the 90° position → 12.1.1 "Roto Patio Inowa" from page 244.
2. Turn the escutcheon cover [2] in order to expose the screw holes.

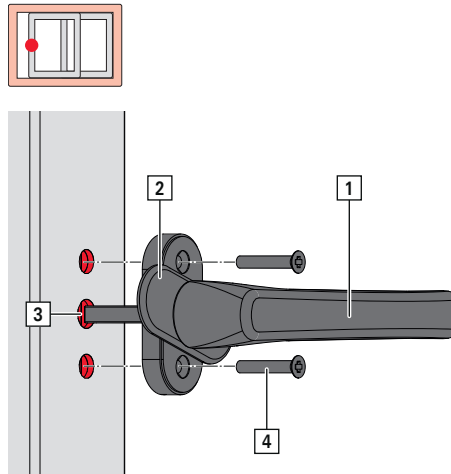

3. Insert the handle into the sash [3].
4. Insert the recessed grip into the sash on the opposite side.
5. Screw the recessed grip through the handle with two screws [4].
6. Turn the escutcheon cover in order to expose the screw holes.

9.5.8 Roller unit

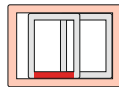

INFO

The roller unit must not be pushed into the timber. Adapt the torque if necessary.
No spacer blocking for load transfer via the middle roller unit.

Positioning the drilling jig



ATTENTION

Improper drilling work may cause property damage.

An incorrect handle position and incorrect alignment of the drilling jig damage the sash during drilling.

- ▶ The handle must be in the open sliding position [1].

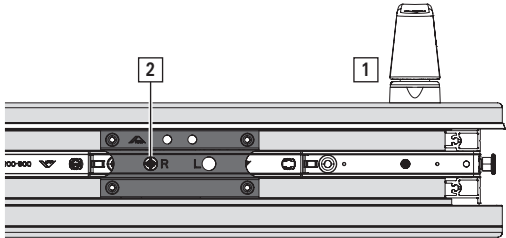
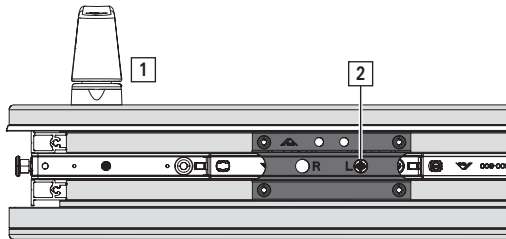
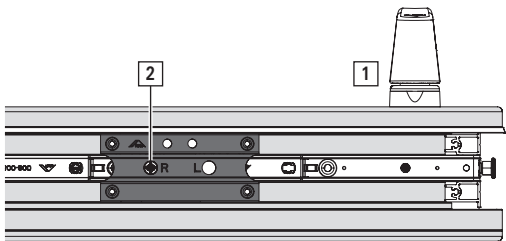
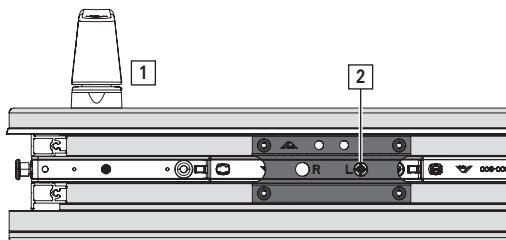

Attach the drilling jig to the cam [2].

Refer to the installation drawing for the position → from page 237.



Installing the roller unit

1. Drill the holes [1].
Drill: timber \varnothing 3.0; PVC \varnothing 3.5
Shown: diagram A, DIN L

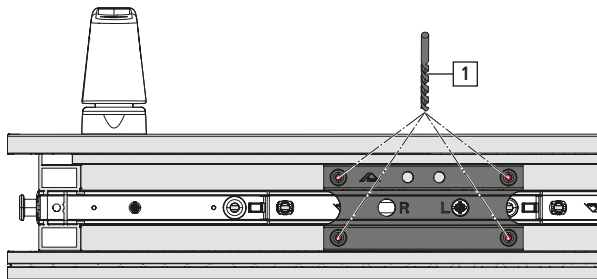

2. Insert the roller unit [2] and fasten with screws [3].

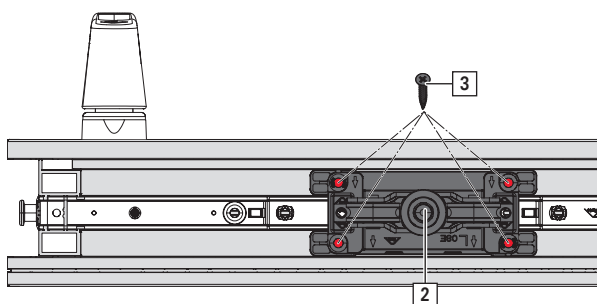

Fitting the brush holder

1. Attach the brush holder [1] on the roller unit, ensuring that the brushes [2] are aligned opposite one another.

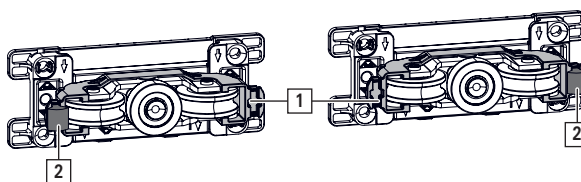

9.5.9 Control unit

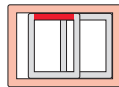

INFO

The control unit must not be pushed into the timber. Adapt the torque if necessary.

For control units with Soft function, ensure that the additional control roller [1] is facing towards the centre of the sash during installation .

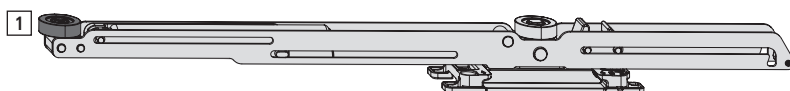

Positioning the drilling jig



ATTENTION

Improper drilling work may cause property damage.

An incorrect handle position and incorrect alignment of the drilling jig damage the sash during drilling.

- ▶ The handle must be in the open sliding position [1].

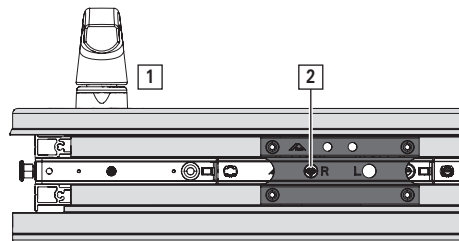
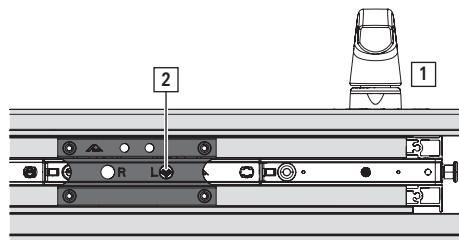
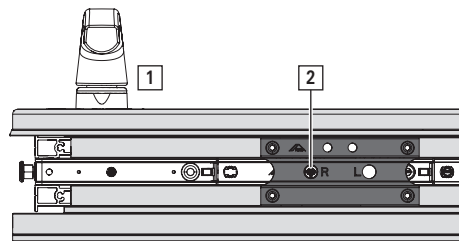
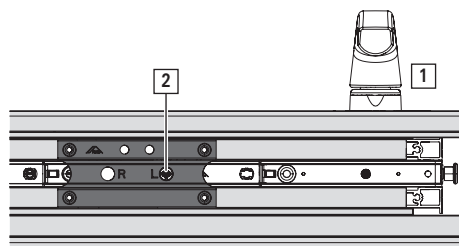

Attach the drilling jig to the cam [2].

Refer to the installation drawing for the position → *from page 237.*



Installing the control unit

1. Drill the holes [1].
Drill: timber \varnothing 3.0; PVC \varnothing 3.5
Shown: diagram A, DIN L

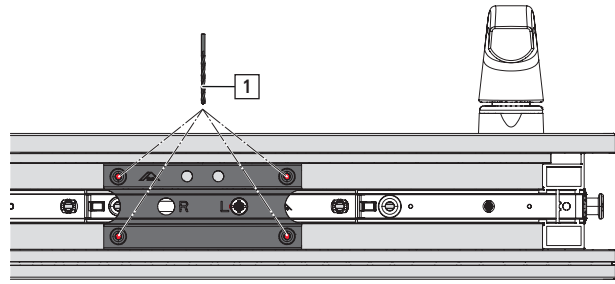

2. Insert the control unit and fasten with screws [2].

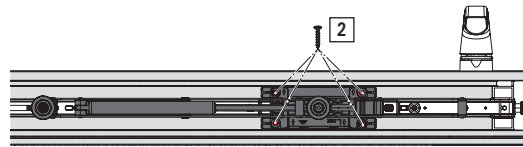

9.5.10 Centre closer

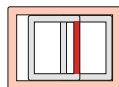

Figures: installation of the non-adjustable version.



INFO

The centre closer must not be pushed into the timber. Adapt the torque if necessary.

Checking the combination of centre closer and mullion locking cam

1. Make sure that the components have been combined correctly:
 - Centre closer, adjustable with mullion locking cam, adjustable and $\varnothing 14.0$ drilling jig.
 - Centre closer with mullion locking cam and $\varnothing 12.0$ drilling jig.

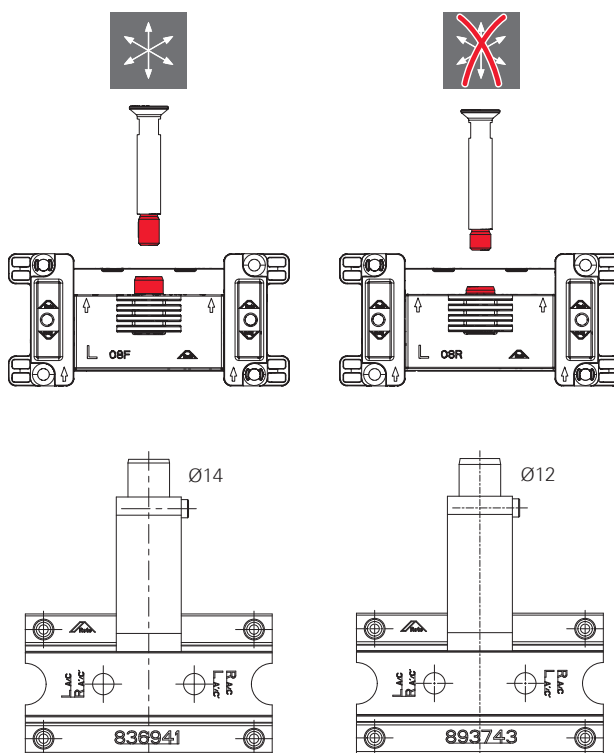



Positioning the drilling jig



ATTENTION

Improper drilling work may cause property damage.

An incorrect handle position and incorrect alignment of the drilling jig damage the sash during drilling.

- ▶ The handle must be in the open sliding position [1].
- ▶ **Inward running sashes:** position the drilling jig so that the side with the $\varnothing 12.0 / 14.0$ drill hole [2] is facing **away** from the handle.
- ▶ **Outward running sashes:** position the drilling jig so that the side with the $\varnothing 12.0 / 14.0$ drill hole [2] is facing **towards** the handle.

Attach the drilling jig to the control cam [3].

Refer to the installation drawing for the position → *from page 237*.



INFO

For both RC 2 and diagram C, drill the holes for the centre closers for anti-pushback function → *from page 186*.

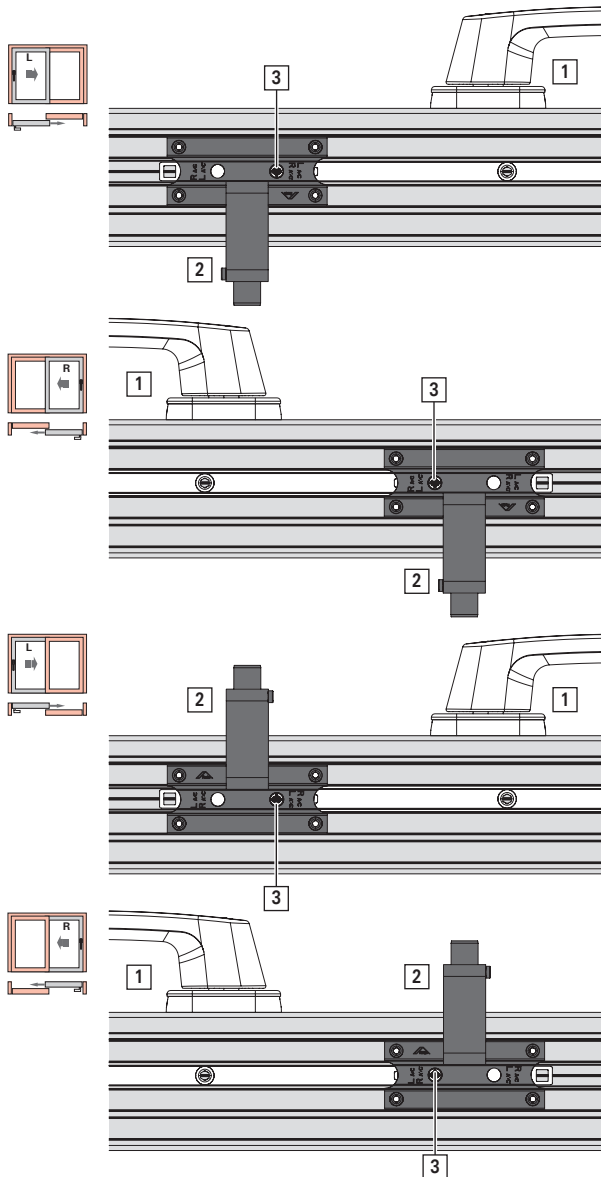

Installing the centre closer

1. Drill holes.

Drill [1]: Ø 12.0 / 14.0

Drill [2]: timber Ø 3.0; PVC Ø 3.5

Shown: diagram A, DIN L

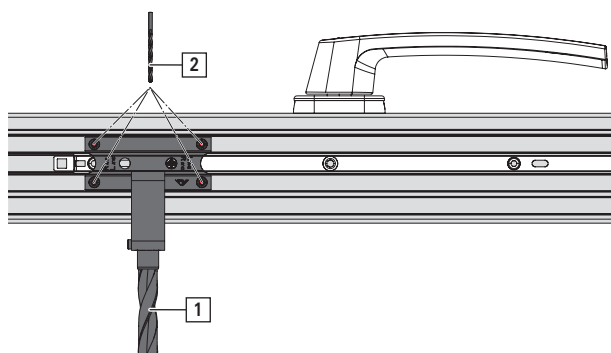

2. Insert the centre closer so that the mullion locking cam mount is facing the drill hole [3] on the outer side of the sash.

Fasten with four screws [4].

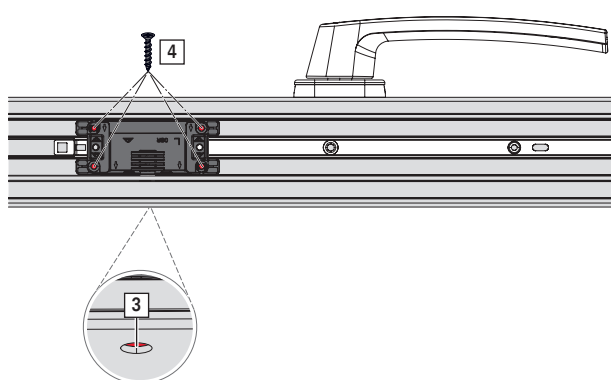

3. Insert the mullion locking cam [5] into the cam guide.

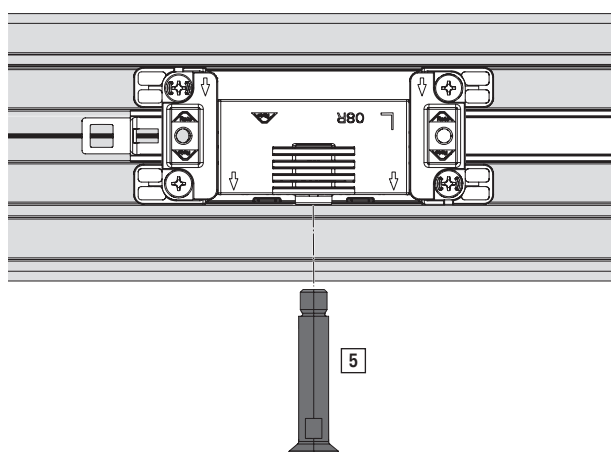



4. Screw down the mullion locking cam.
Tool: size 8 open-end spanner / size 4 hex key



INFO

Tighten the mullion locking cam so that it is hand-tight.

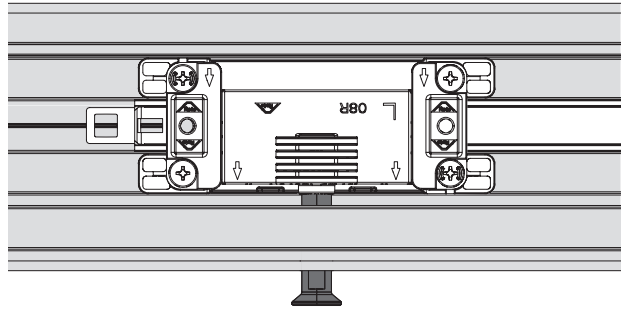

9.5.11 Centre closer for anti-pushback function

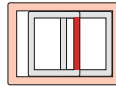

INFO

Diagram A / C: install right components for DIN L; install left components for DIN R.

Diagram A' / C': install left components for DIN L; install right components for DIN R.

Drilling with a Ø 14.0 drilling jig is mandatory for the centre closer, adjustable.

The centre closer must not be pushed into the timber. Adapt the torque if necessary.

Figures: installation of the non-adjustable version.

Positioning the drilling jig



ATTENTION

Improper drilling work may cause property damage.

An incorrect handle position and incorrect alignment of the drilling jig damage the sash during drilling.

- ▶ The handle must be in the open sliding position.
- ▶ **Inward running sashes:** position the drilling jig so that the side with the Ø 12.0 / 14.0 drill hole [1] is facing **away** from the handle.
- ▶ **Outward running sashes:** position the drilling jig so that the side with the Ø 12.0 / 14.0 drill hole [1] is facing **towards** the handle.

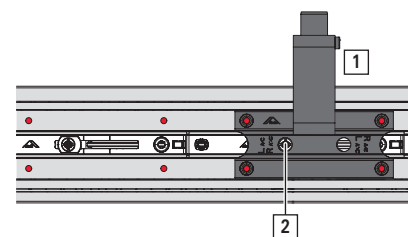
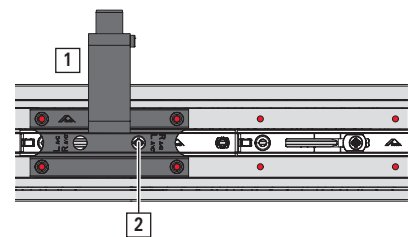
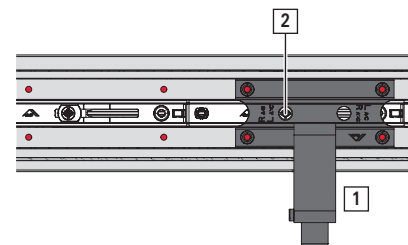
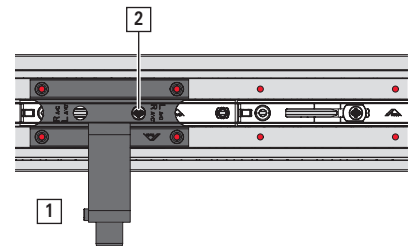

Attach the drilling jig to the control cam [2].

Refer to the RC installation drawing or diagram C for the position → *from page 237*.



Installing the centre closer for anti-pushback function

1. Drill holes.
 Drill [1]: Ø 12.0 / 14.0
 Drill [2]: timber Ø 3.0; PVC Ø 3.5
 Shown: diagram A, DIN L

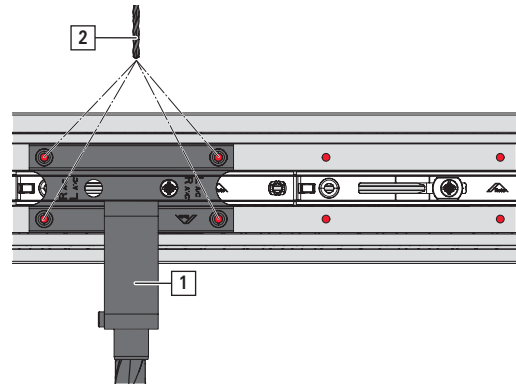

2. Install the centre closer → *from page 182*.
 Move the handle to the closed position.

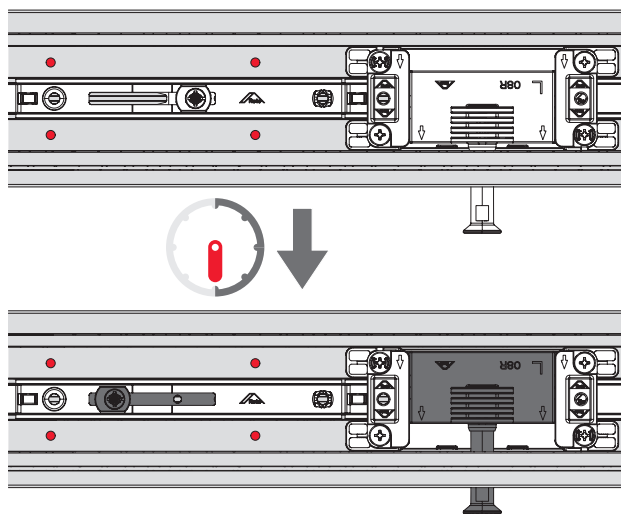

3. Insert the centre closer so that the mullion locking cam mount is facing the drill hole [3] on the outer side of the sash.
 Fasten with four screws [4].

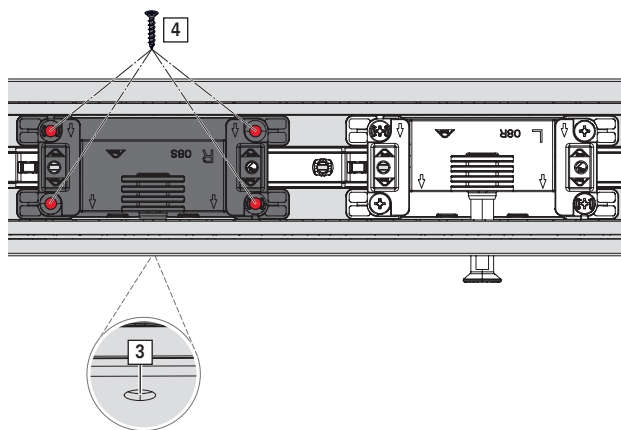

Installation

Sash

Centre closer for anti-pushback function

4. Insert the pin for anti-pushback function [5] into the cam guide.

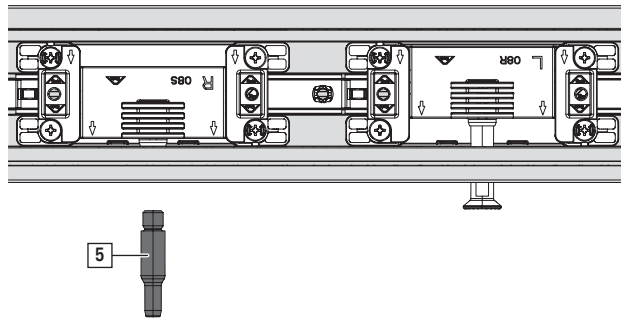

5. Fasten the pin for anti-pushback function.
Tool: size 3 hex key.



INFO

Tighten the pin for anti-pushback function so that it is hand-tight.

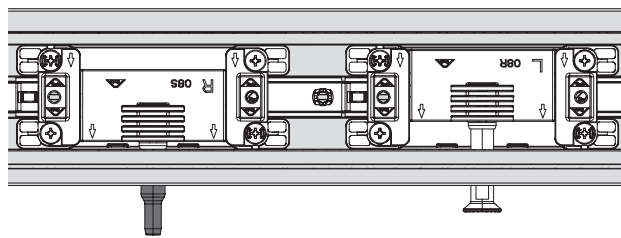



9.5.12 Rubber buffer



INFO

Timber: install the rubber buffer in the frame → 9.6.5 "Rubber buffer" from page 206.

Installing rubber buffers

1. Install the profile-related cover on the mullion side. Ensure that the guide track and roller track are running smoothly.

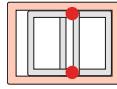

INFO

Place pressure-proof packers underneath the cover at the top and bottom in the hatched area for installing the rubber buffers. Ensure that the cam on the corner drive is running smoothly.

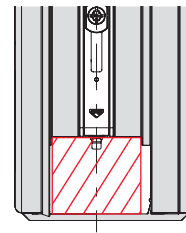

2. Drill two holes $\varnothing 10$ mm for rubber buffers at the top and bottom of the cover.



INFO

The dimension X for the drill hole is profile-related.

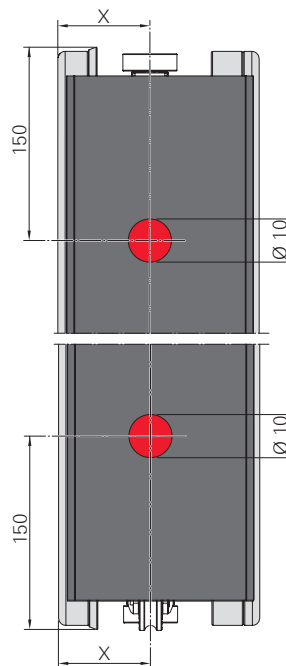

3. Insert the rubber buffer [1].

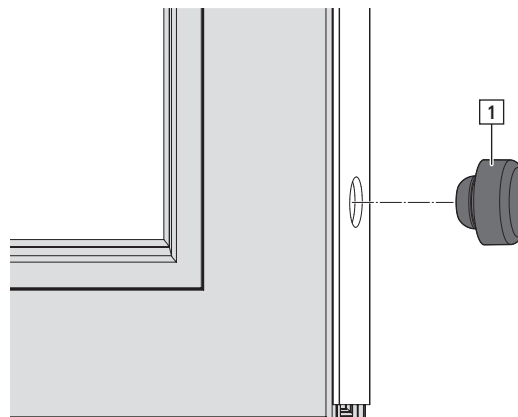

9.5.13 Cover profile

The cover profile is customer-specific and must be notched at the top and bottom prior to installation.

Notching the cover profile

1. Crop the cover profile to the sash height (SH).
Notch the cover profile at the top in the operator track [1] area and at the bottom in the roller track [2] area.

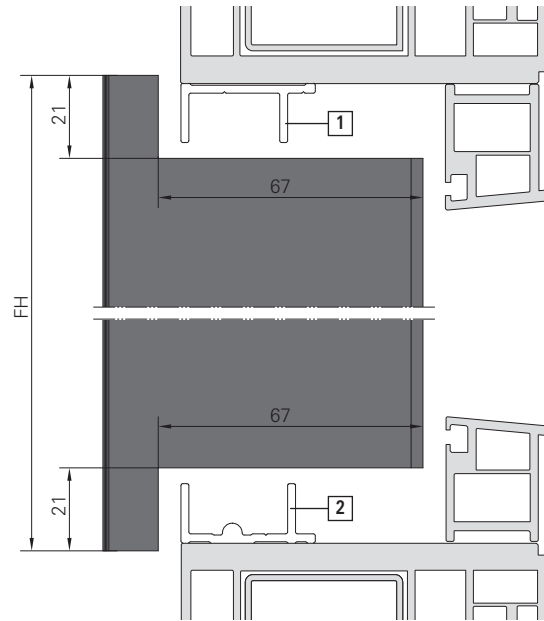



9.5.14 Components in the floating mullion



INFO

The installation of the operating sequence control is only shown as an example. For profile-related installation, see the profile assessment.

Diagram C / C' – timber

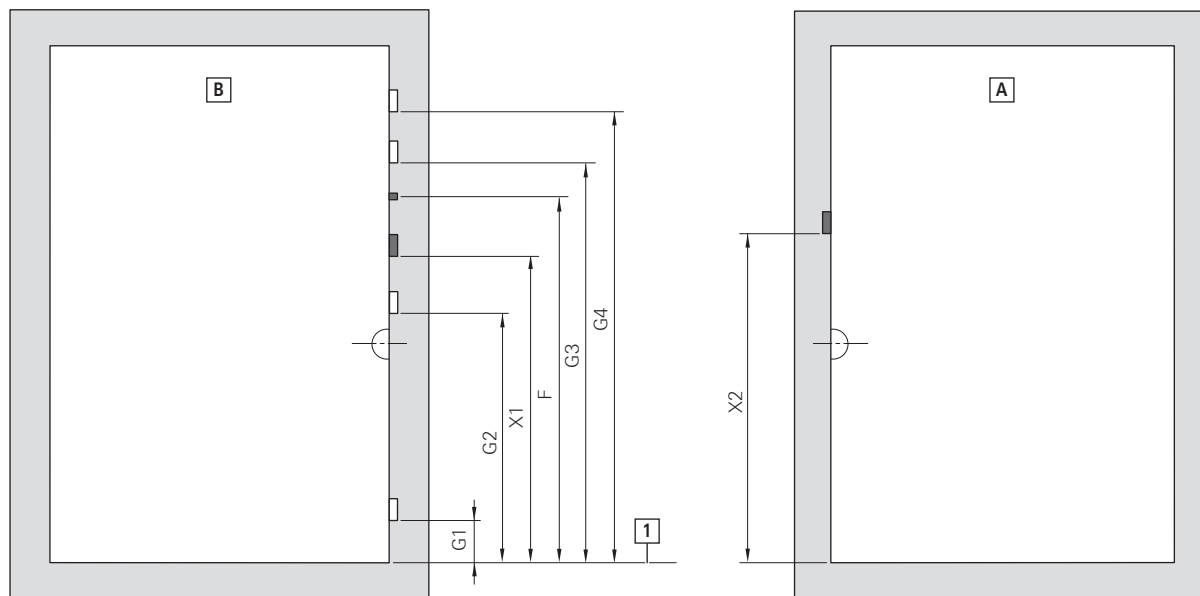

[1] Sash rebate edge

□ Striker, diagram C

■ Operating sequence control: [F] Bolt, [X1] Anti-lifting device, [X2] Stop, routed

First opening sash

| SRH [mm] | X2 |
|-------------|------|
| 600 – 800 | – |
| 801 – 1000 | – |
| 1001 – 1200 | – |
| 1201 – 1400 | 819 |
| 1401 – 1600 | 819 |
| 1601 – 1800 | 1206 |
| 1801 – 2000 | 1551 |
| 2001 – 2200 | 1551 |
| 2201 – 2400 | 1551 |
| 2401 – 2500 | 1595 |

Second opening sash

| SRW [mm] | G1 | G2 | G3 | G4 | F | X1 |
|-------------|----|----------|----------|----------|------|------|
| 600 – 800 | 51 | SRH – 59 | – | – | – | – |
| 801 – 1000 | 51 | SRH – 59 | – | – | – | – |
| 1001 – 1200 | 51 | 675 | SRH – 59 | – | 766 | – |
| 1201 – 1400 | 51 | 675 | SRH – 59 | – | 853 | 793 |
| 1401 – 1600 | 51 | 675 | SRH – 59 | – | 853 | 793 |
| 1601 – 1800 | 51 | 675 | SRH – 59 | – | 1239 | 1180 |
| 1801 – 2000 | 51 | 675 | 1345 | SRH – 59 | 1585 | 1525 |
| 2001 – 2200 | 51 | 675 | 1345 | SRH – 59 | 1585 | 1525 |
| 2201 – 2400 | 51 | 675 | 1345 | SRH – 59 | 1585 | 1525 |
| 2401 – 2500 | 51 | 675 | 1745 | SRH – 59 | 1629 | 1569 |



Installing the operating sequence control

1. Move the handle of the second opening sash to the closed sliding position.
2. Attach the bolt at the position provided [1] on the espagnolette of the second opening sash. The marking (red) points up. Fasten with one screw [2].

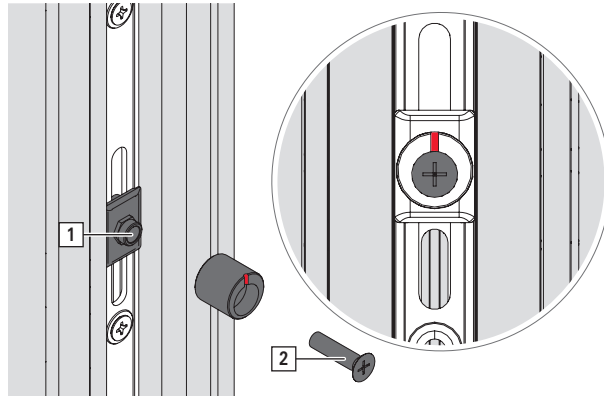

3. Push the first opening sash shut until the lower edge [A] of the bolt can be transferred to the first opening sash. Open the first opening sash again and pre-position the stop [3] on the first opening sash with two screws [4] in slots, at an offset of 2 mm from the lower edge of the bolt. Check the position and fasten with an additional two screws [5]. Push the first opening sash shut until the lower edge [B] of the stop can be transferred to the second opening sash. Open the first opening sash again and fasten the anti-lifting device [6] to the second opening sash with two screws, at an offset of 2 mm from the stop.

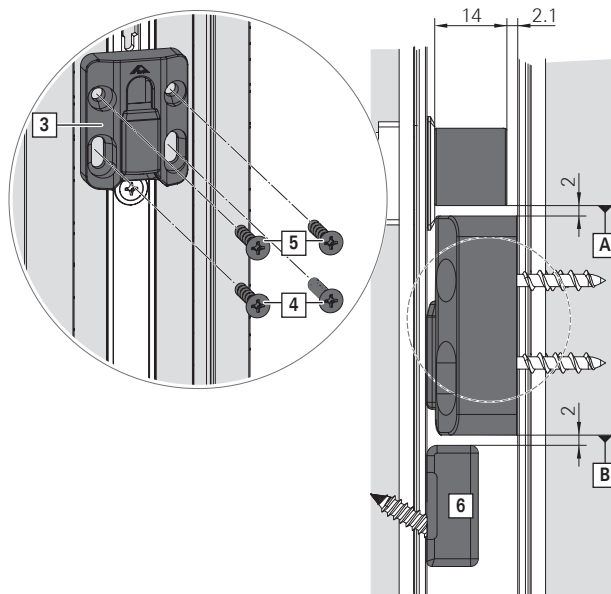

Striker, diagram C, dimensional drawing in open sliding position

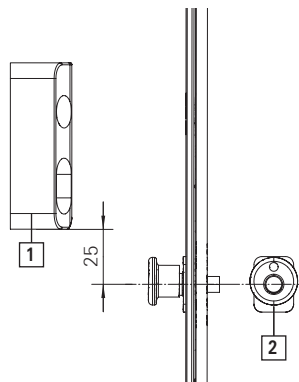

- [1] Striker, diagram C
- [2] Locking cam

Installing the striker, diagram C

1. Pre-position the striker, diagram C [1] with two screws [2] in the slots.
Check the position and fasten with an additional two screws [3].

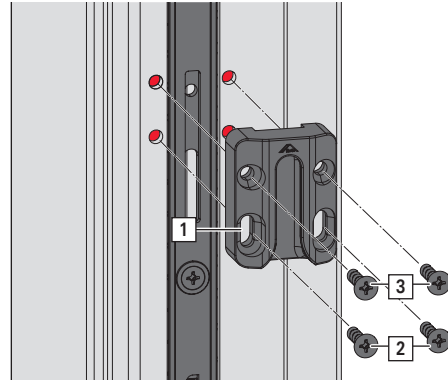
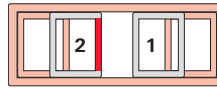
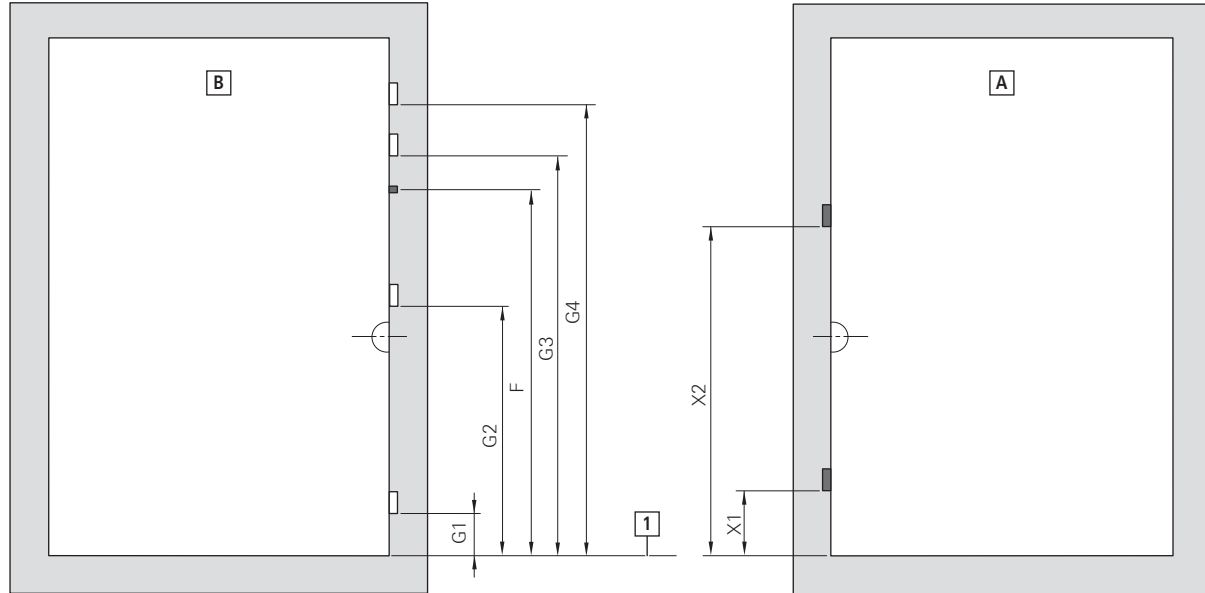



Diagram C – PVC



[A] First opening sash; [B] Second opening sash

[1] Sash rebate edge

□ Striker, screw-on: to prevent incorrect operation G1[1], standard G2[2]

■ Operating sequence control: striker with buffer [X2], cam / trapezoid [F], anti-lifting device [X1]

First opening sash

| SRH [mm] | X1 | X2 |
|-------------|----|------|
| 600 – 800 | – | – |
| 801 – 1000 | – | – |
| 1001 – 1200 | 89 | 732 |
| 1201 – 1400 | 89 | 819 |
| 1401 – 1600 | 89 | 819 |
| 1601 – 1800 | 89 | 1206 |
| 1801 – 2000 | 89 | 1551 |
| 2001 – 2200 | 89 | 1551 |
| 2201 – 2400 | 89 | 1551 |
| 2401 – 2500 | 89 | 1595 |

Second opening sash

| SRH [mm] | G1[1] | G1[2] | G2 | G3 | G4 | F |
|-------------|-------|-------|----------|----------|----------|------|
| 600 – 800 | 51 | 62 | SRH – 48 | – | – | – |
| 801 – 1000 | 51 | 62 | SRH – 48 | – | – | – |
| 1001 – 1200 | 51 | 62 | 686 | SRH – 48 | – | 766 |
| 1201 – 1400 | 51 | 62 | 686 | SRH – 48 | – | 853 |
| 1401 – 1600 | 51 | 62 | 686 | SRH – 48 | – | 853 |
| 1601 – 1800 | 51 | 62 | 686 | SRH – 48 | – | 1239 |
| 1801 – 2000 | 51 | 62 | 686 | 1356 | SRH – 48 | 1585 |
| 2001 – 2200 | 51 | 62 | 686 | 1356 | SRH – 48 | 1585 |
| 2201 – 2400 | 51 | 62 | 686 | 1356 | SRH – 48 | 1585 |
| 2401 – 2500 | 51 | 62 | 686 | 1756 | SRH – 48 | 1629 |

Installing the operating sequence control**First opening sash**

1. Pre-position the striker with buffer [1] in the slots with two screws [2].
Check the position and fasten with an additional two screws [3].

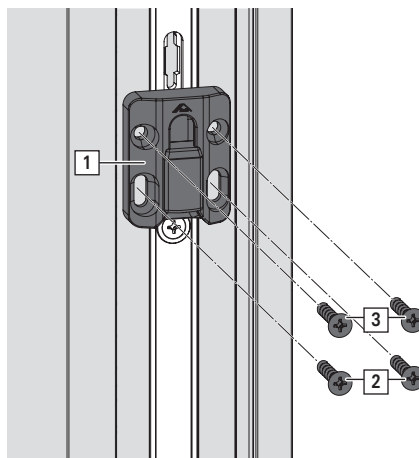

2. Position the anti-lifting device [4] and fasten with two screws.

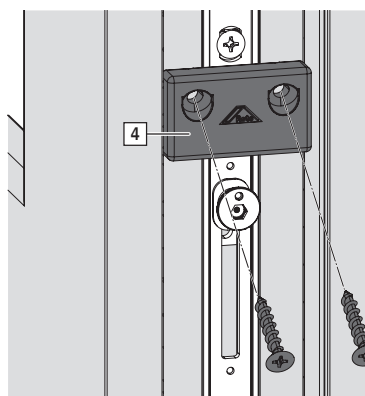
**Second opening sash**

1. Position the strikers and fasten with two screws → *9.7.3 "Striker, screw-on" from page 212.*
2. Version 1:
Attach the bolt at the position provided on the espagnolette [1] so that the marking (red) points up.
Fasten with one screw [2].

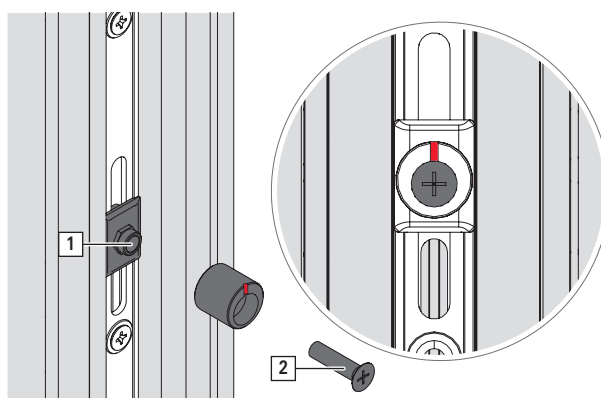



Version 2:

Screw the pin for anti-pushback function [1] into the trapezoid [2] as far as it will go. Attach it at the position provided on the espagnolette .

Fasten with one screw [3].

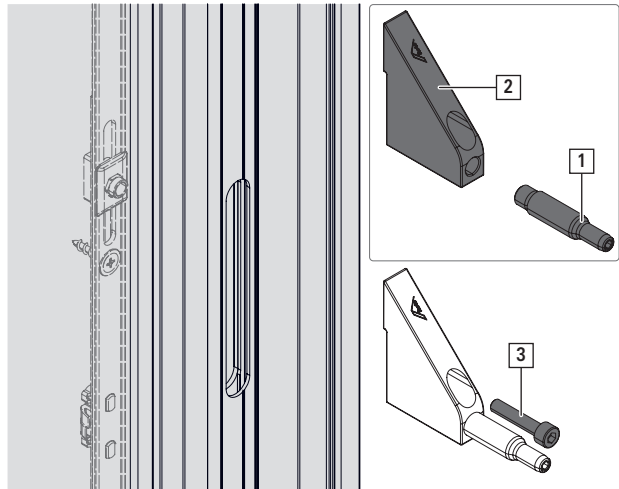

9.6 Frame

9.6.1 Roller track



INFO

Pay attention to the profile assessment.

- Adapt the width of the roller track under your own responsibility.
- Seal the roller track properly under your own responsibility. Prevent water from entering underneath the roller track.
- Fit a water drain under your own responsibility so that water is drained away to the outside in a controlled manner.
- Ensure that the roller track is securely attached.
- Protect the roller track against contamination and additional surface treatment.

Version with continuous roller track

Diagram A' is shown here.

Timber

1. Cut the roller track [1] to size.

$$X = \text{FIW} - 2$$

$$Y = \text{profile width}$$

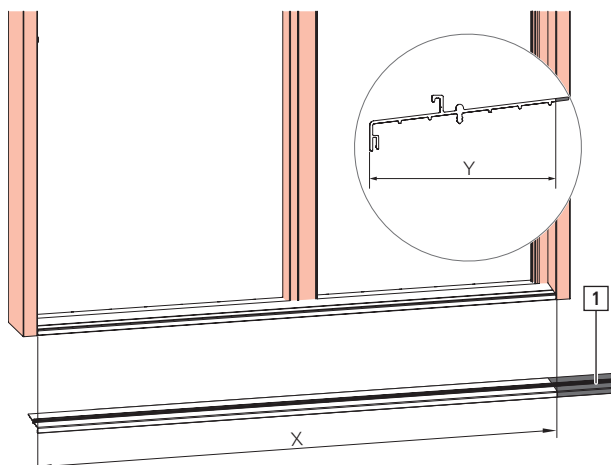
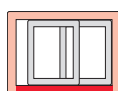

2. Place the roller track on the threshold [2] and press down firmly into the threshold groove [3].

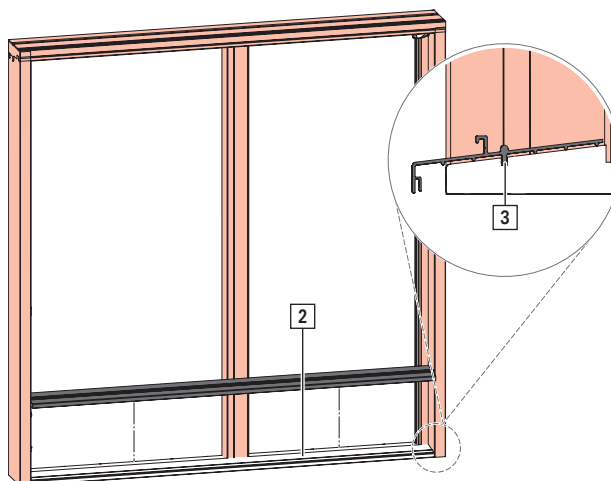



Salamander | evolutionDrive Plus+ and Schüco | Living move

1. Cut the roller track [1] to size.
 - Salamander | evolutionDrive Plus+: X = FEW - 78
 - Schüco | Living move: X = FEW - 90

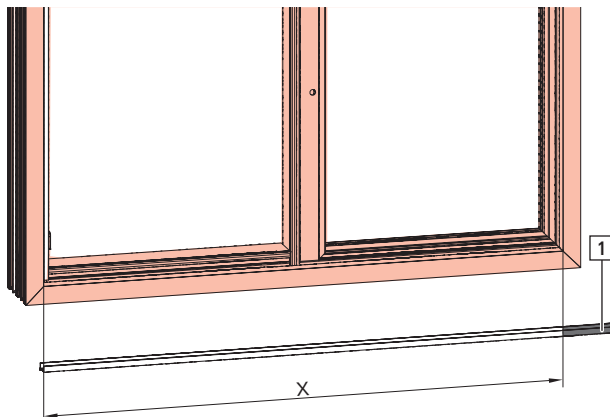
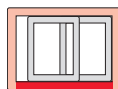

2. Place the roller track on the threshold [2].

Pre-drill the roller track with frame profile in the area of the steel reinforcement (at a distance of max. 300 mm).

Fasten the roller track in all pre-drilled holes using screws [3].

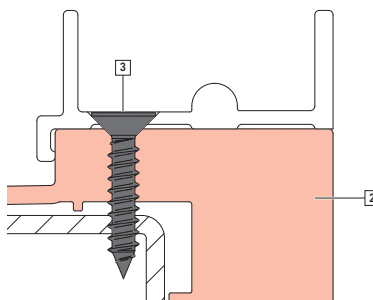

Version with split roller track

Diagram C' is shown here.

Timber

1. Cut the roller tracks [1] to size.



INFO

Ensure that the drainage holes are located at least 50 mm away from the edge.

Cut both roller tracks to the same length.

$$X = \text{FIW} - 2$$

$$Y = \text{profile width}$$

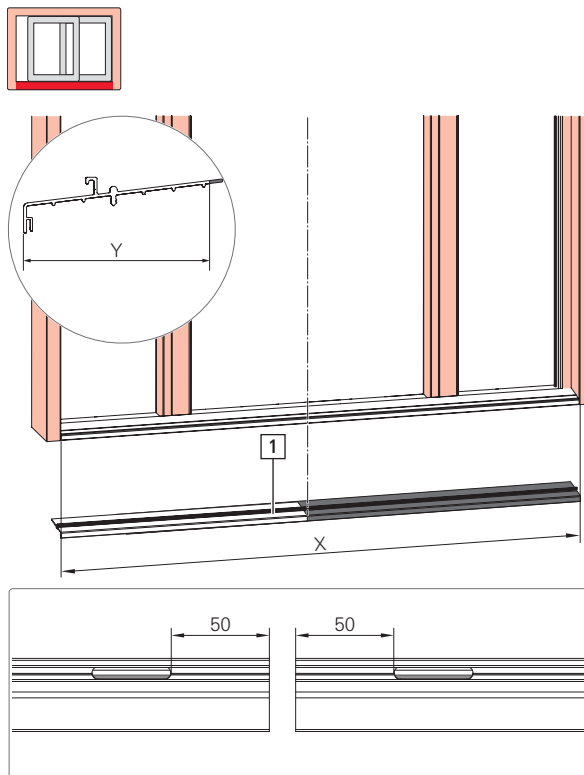

2. Remove the roller track grooves in the joint area.

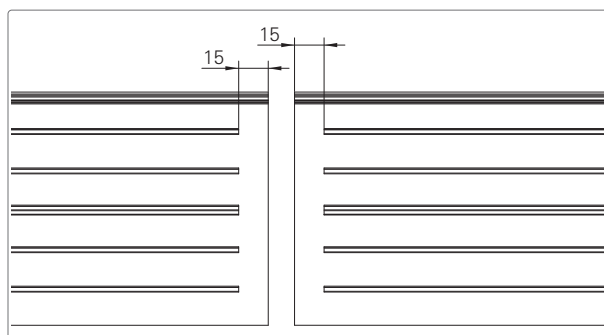

3. Attach a sealing strip [2] as a connection element between the two roller tracks.

Place the roller tracks on the threshold [3] and press down firmly into the threshold groove [4].

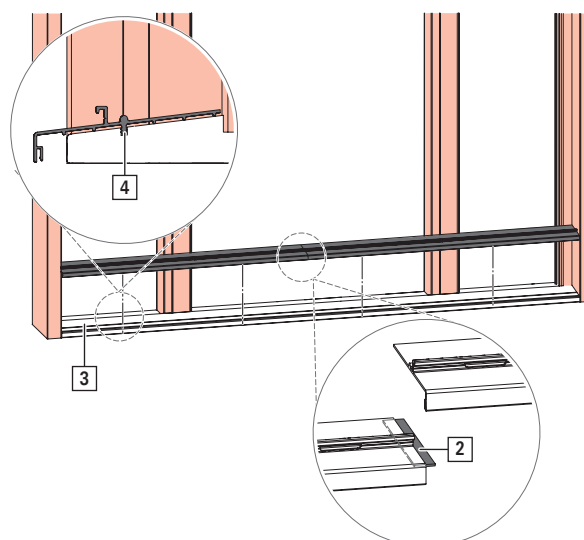



9.6.2 Operator track



ATTENTION

Protruding screw heads may cause property damage.

Protruding screw heads in the area of the activator can damage the control unit when opening the sash.

1. Do not screw the operator track in the area of the activator.



INFO

- Pay attention to the system-specific profile assessment.
- Seal the guide track properly under your own responsibility. Prevent water from entering underneath the guide track.
- Ensure that the guide track is securely attached.
Adhere to a screw spacing of max. 300 mm.

Preparing the operator track – version with split operator track

1. Cut the operator track for the access area to size and predrill it.

$$X = (FIW - 2) / 2$$

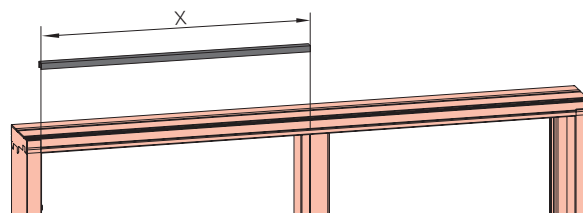
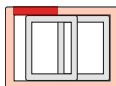

2. Cut the operator track for the fixed glazing area to size and predrill it.

$$Y = FIW - X$$

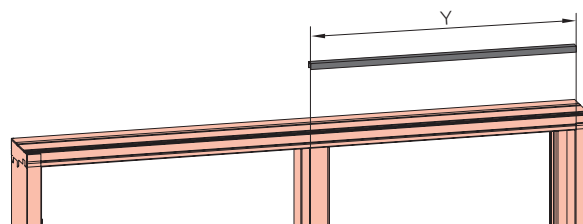
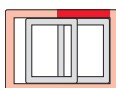

Preparing the operator track – version with split operator track

Only applicable to Salamander | evolutionDrive Plus+ and Schüco | Living move

1. Cut the operator track for the access area to size and predrill it.
 - Salamander | evolutionDrive Plus+: $X = (FEW / 2) - 94$
 - Schüco | Living move: $X = (FEW / 2) - 160$

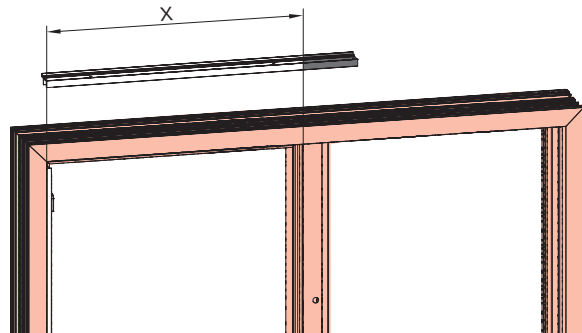
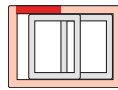

2. Cut the operator track for the fixed glazing area to size and predrill it.
 - Salamander | evolutionDrive Plus+:
 $Y = (FEW / 2) + 16$
 - Schüco | Living move: $Y = (FEW / 2) + 51$

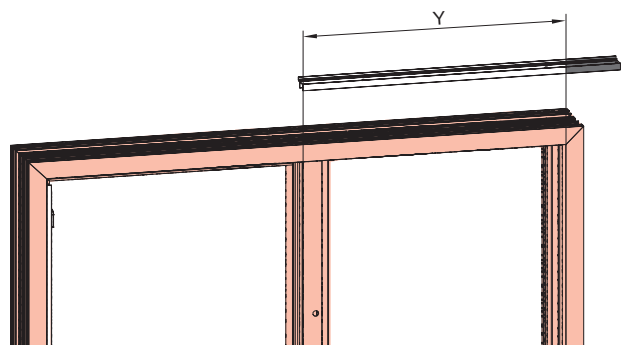
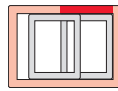

Installing the operator track in the access area – version with split operator track

Only applicable to Salamander | evolutionDrive Plus+ and Schüco | Living move

1. Insert the operator track into the frame in the access area and fasten with screws [1] (screws spaced max. 300 mm apart).

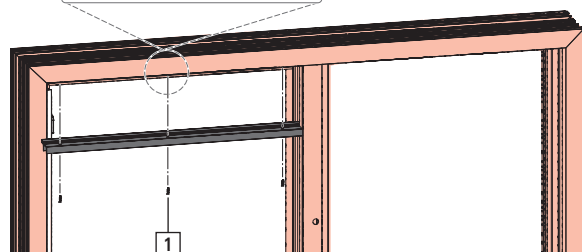
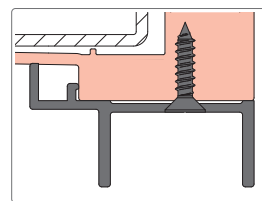



2. **RC 2 / RC 2 N** (only applicable to Salamander | evolutionDrive Plus+)
Predrill the frame profile in the area of the steel reinforcement (at a distance of max. 300 mm).
Fasten the operator track with additional screws.

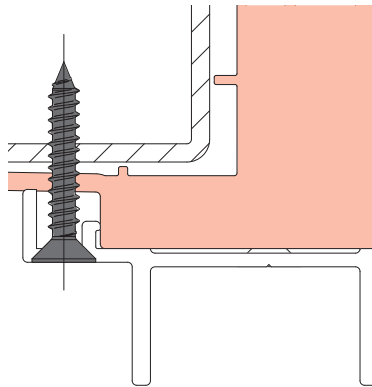

Installing the operator track in the access area – version with split operator track

1. Insert the operator track into the frame in the access area and fasten with screws [1] (screws spaced max. 300 mm apart).

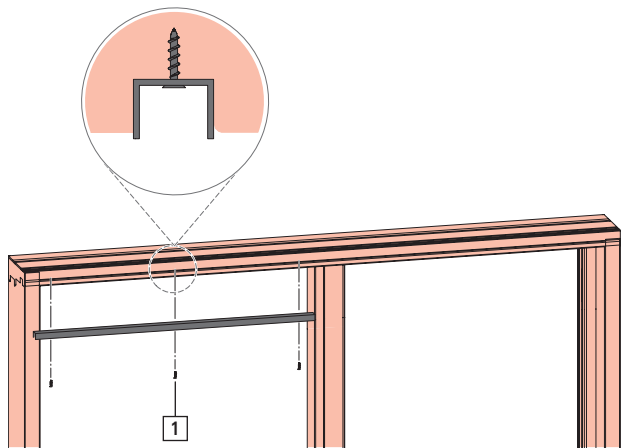

INFO

Only install the operator track in the fixed glazing area once the sash has been inserted.

9.6.3 Frame adapter profile

Only applicable to Salamander | evolutionDrive Plus+ and Schüco | Living move

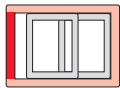

Preparing the adapter profile

1. Crop the adapter profile [1].
 - Salamander | evolutionDrive Plus+: X = FEH - 106
 - Schüco | Living move: X = FEH - 120

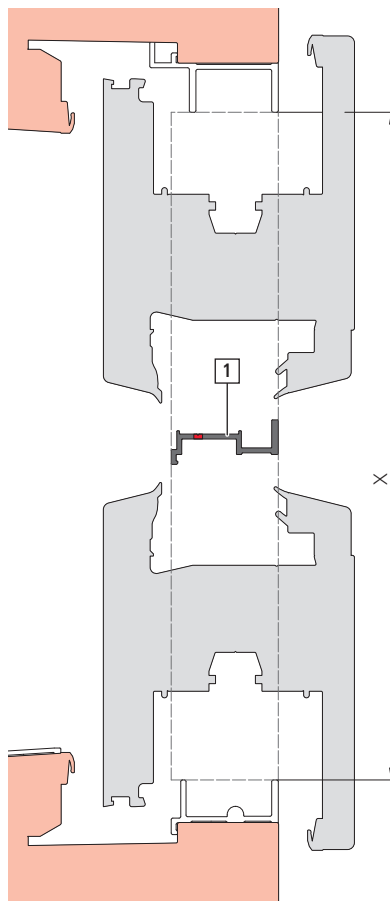

Installing the adapter profile

1. Fasten the adapter profile, together with strikers and buffer, to the frame on the locking side.



- Only applicable to Salamander | evolutionDrive Plus+: Also fasten the adapter profile in the centre between two strikers or between the buffer and striker using one flat-headed screw [1] each with drill point in the groove provided.

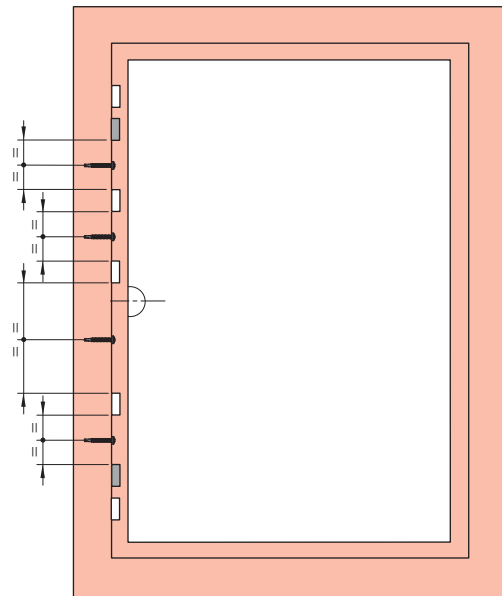
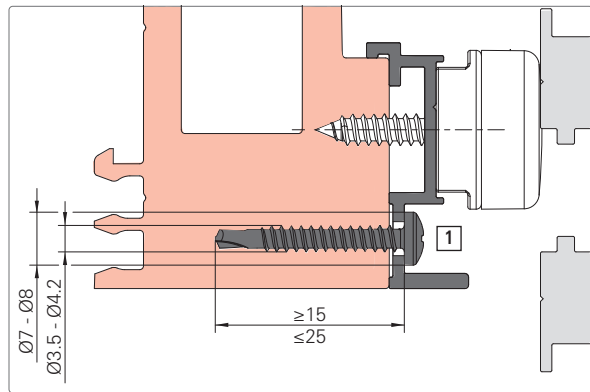

9.6.4 Gasket pad

Only applicable to Salamander | evolutionDrive Plus+ and Schüco | Living move

- Apply adhesive to the entire underside of the gasket pad.
 Push the gasket pad [1] under the roller track [2] in the fixed glazing area, at a distance [X] from the floating mullion, and adhere it to the threshold.
 Salamander | evolutionDrive Plus+: X = 15
 Schüco | Living move with T-profile 82/112 AS: X = 35
 Schüco | Living move with T-profile 82/92 AS: X = 15

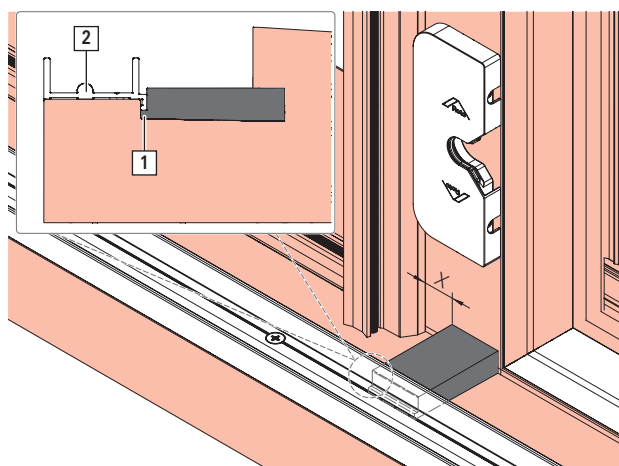

9.6.5 Rubber buffer



Installing rubber buffers

1. Insert the rubber buffer [1].

**INFO**

Note the drilling specifications → *from page 169.*

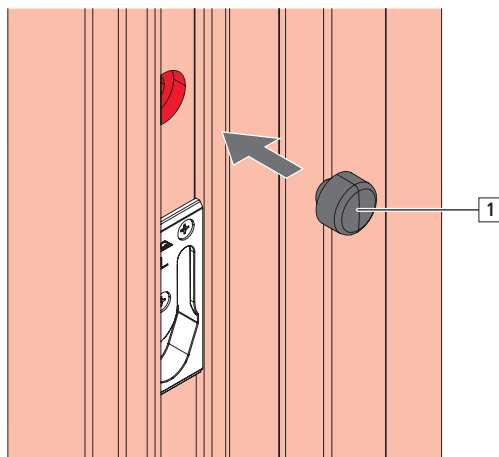
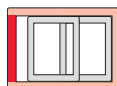

9.7 Joining the sash and frame

**CAUTION****Heavy loads pose a risk of injury.**

Lifting and carrying heavy loads in an uncontrolled manner may lead to physical injury.

- ▶ Transport and installation must be carried out by at least two people.
- ▶ Use transportation means. → *15 "Transport" from page 252*
- ▶ Note the applicable accident prevention regulations.

**ATTENTION****Heavy loads may cause property damage.**

Lifting and carrying heavy loads in an uncontrolled manner may lead to property damage.

- ▶ Transport and installation must be carried out by at least two people.
- ▶ Use transportation means. → *15 "Transport" from page 252*
- ▶ Do not rest sashes on the rollers.



9.7.1 Inserting the sash



WARNING

An unsecured sash may pose a risk of death!

The sash may fall during installation if it is not securely connected to the frame.

- ▶ Secure the sash to prevent it from falling, e.g. by using two people.



INFO

- Pay attention to the system-specific profile assessment.
- Seal the guide track properly under your own responsibility. Prevent water from entering underneath the guide track.
- Ensure that the guide track is securely attached.
Adhere to a screw spacing of max. 300 mm.

Version with split operator track, inserting the sash at the bottom

The operator track is installed in the access area.

The operator track for the fixed glazing area is prepared → *from page 201*.

1. Move the handle to the open sliding position



2. In front of the fixed glazing area, insert the sash at the bottom of the frame and position the roller unit on the roller track without impact.

For roller tracks with just one wall, ensure that the roller unit rollers are not set down next to the roller track.

Check that the roller unit rollers are correctly positioned on the roller track by pushing the sash.

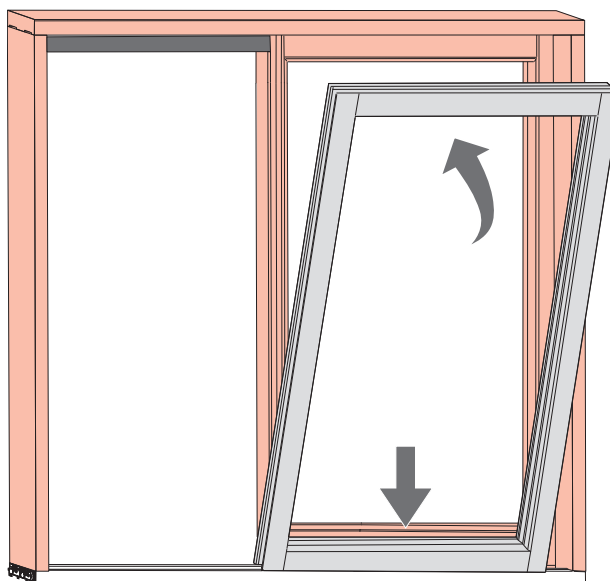

Installation

Joining the sash and frame

Inserting the sash

3. Push the sash onto the roller track in front of the access area in a controlled manner until all control units are located in the operator track that is already installed.

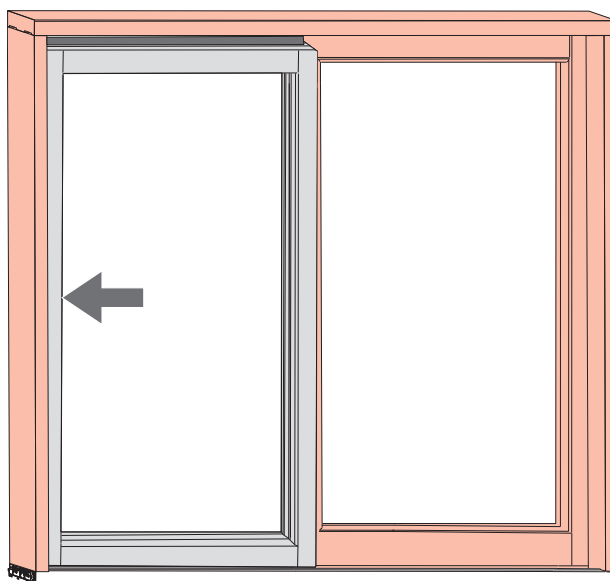

4.

Move the handle to the closed position



5. Insert the prepared operator track into the frame in the fixed glazing area and fasten with screws (screws spaced max. 300 mm apart).

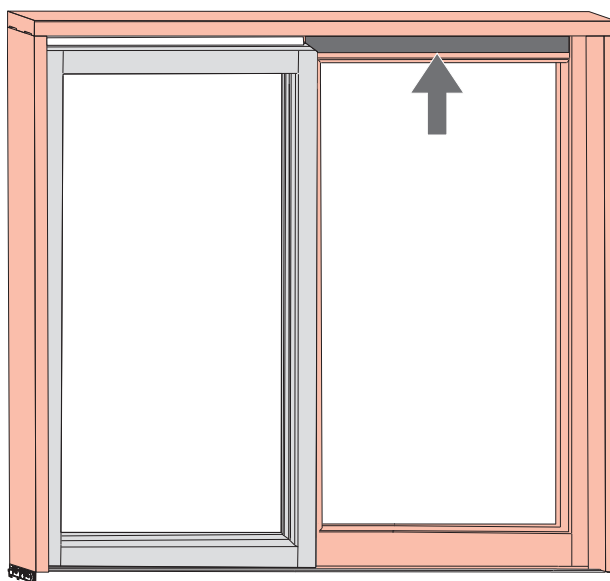

6. **RC 2 / RC 2 N** (only applicable to Salamander | evolutionDrive Plus+)
Predrill the frame profile in the area of the steel reinforcement (at a distance of max. 300 mm).
Fasten the operator track with additional screws.

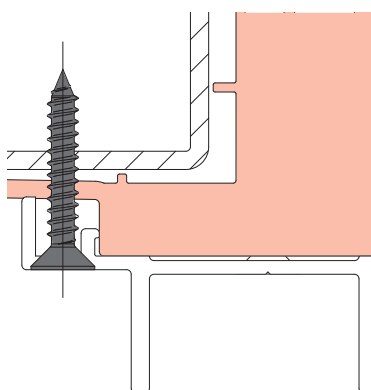



9.7.2 Frame component position

Diagram A

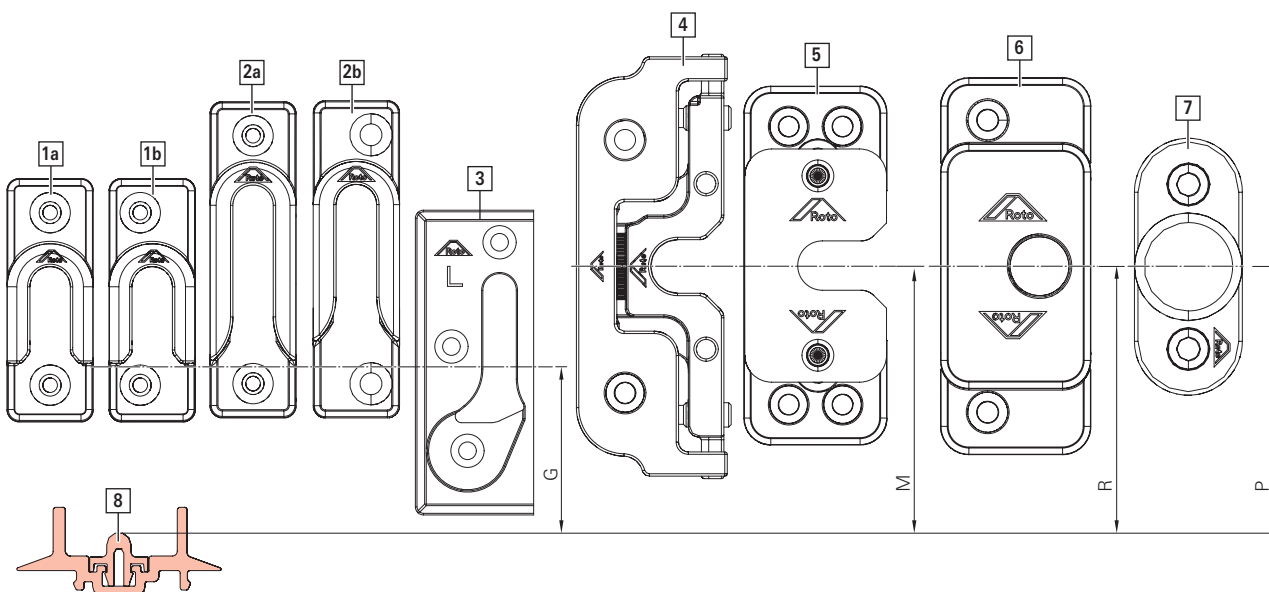

- [1a] Striker, for timber and PVC, screw-on (G1 - G4)
- [1b] Striker (DIN R), for Salamander | evolutionDrive Plus+, screw-on (G1 - G4)
- [2a] Striker to prevent incorrect operation (G1)
- [2b] Striker to prevent incorrect operation (DIN L), for Salamander | evolutionDrive Plus+ (G1)
- [3] Striker (DIN L), for timber, can be routed in (G1 - G4)
- [4] Mullion striker (M1 - M4)
- [5] Mullion security striker (M1 - M4)
- [6] Striker for anti-pushback function (S1 - S2)
- [7] Buffer
- [8] Roller track

i INFO

- Align the striker, screw-on, with the point of entry.
- Insert the striker, which can be routed in, in the centre of the routing.
- Align the mullion striker in the centre.
- Dimensions M1 - M4 apply to the coverage between the operator track and control unit of ≥ 9 mm.
- Pay attention to the profile assessment.

Installation

Joining the sash and frame

Frame component position

Standard

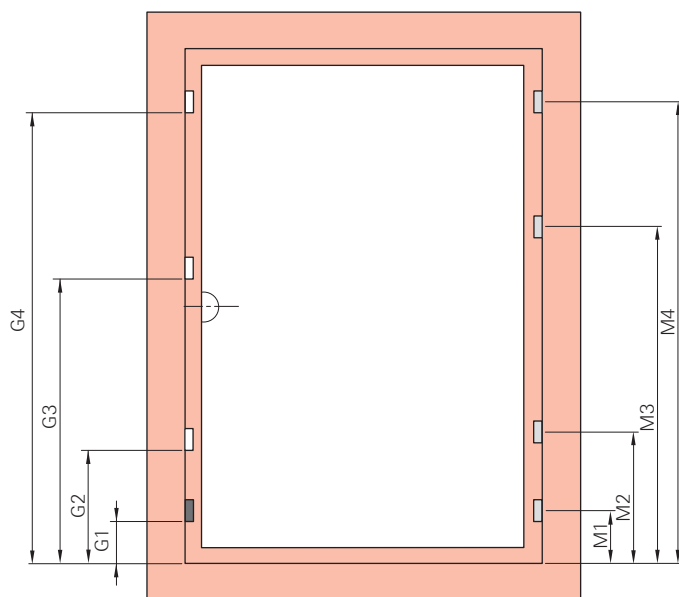

□ Striker

■ Striker, screw-on [1], striker to prevent incorrect operation [2] or striker, can be routed in

□ Mullion striker

Striker, screw-on, on the locking side

| SRH / mm | G1 [1] | G1 [2] | G2 [1] | G3 [1] | G4 [1] |
|-------------|--------|--------|--------|--------|--------|
| 600 - 800 | 97 | 86 | SRH-13 | – | – |
| 801 - 1000 | 97 | 86 | SRH-13 | – | – |
| 1001 - 1200 | 97 | 86 | 721 | SRH-13 | – |
| 1201 - 1400 | 97 | 86 | 721 | SRH-13 | – |
| 1401 - 1600 | 97 | 86 | 721 | SRH-13 | – |
| 1601 - 1800 | 97 | 86 | 721 | SRH-13 | – |
| 1801 - 2000 | 97 | 86 | 721 | 1391 | SRH-13 |
| 2001 - 2200 | 97 | 86 | 721 | 1391 | SRH-13 |
| 2201 - 2400 | 97 | 86 | 721 | 1391 | SRH-13 |
| 2401 - 2500 | 97 | 86 | 721 | 1791 | SRH-13 |

Striker, on the locking side, can be routed in

| SRH / mm | G1 | G2 | G3 | G4 |
|-------------|----|--------|--------|--------|
| 600 - 800 | 94 | SRH-16 | – | – |
| 801 - 1000 | 94 | SRH-16 | – | – |
| 1001 - 1200 | 94 | 718 | SRH-16 | – |
| 1201 - 1400 | 94 | 718 | SRH-16 | – |
| 1401 - 1600 | 94 | 718 | SRH-16 | – |
| 1601 - 1800 | 94 | 718 | SRH-16 | – |
| 1801 - 2000 | 94 | 718 | 1388 | SRH-16 |
| 2001 - 2200 | 94 | 718 | 1388 | SRH-16 |
| 2201 - 2400 | 94 | 718 | 1388 | SRH-16 |
| 2401 - 2500 | 94 | 718 | 1788 | SRH-16 |

MUL striker, on the mullion

| SRH / mm | M1 | M2 | M3 | M4 |
|-------------|----|---------|--------|----|
| 600 - 800 | 91 | SRH-21 | – | – |
| 801 - 1000 | 91 | SRH-21 | – | – |
| 1001 - 1200 | 91 | SRH-21 | – | – |
| 1201 - 1400 | 91 | SRH-619 | SRH-21 | – |



| SRH / mm | M1 | M2 | M3 | M4 |
|-------------|----|----------|---------|--------|
| 1401 - 1600 | 91 | SRH-619 | SRH-21 | - |
| 1601 - 1800 | 91 | SRH-619 | SRH-21 | - |
| 1801 - 2000 | 91 | SRH-819 | SRH-21 | - |
| 2001 - 2200 | 91 | SRH-1019 | SRH-21 | - |
| 2201 - 2400 | 91 | SRH-1219 | SRH-219 | - |
| 2401 - 2500 | 91 | SRH-1619 | SRH-819 | SRH-21 |

Security

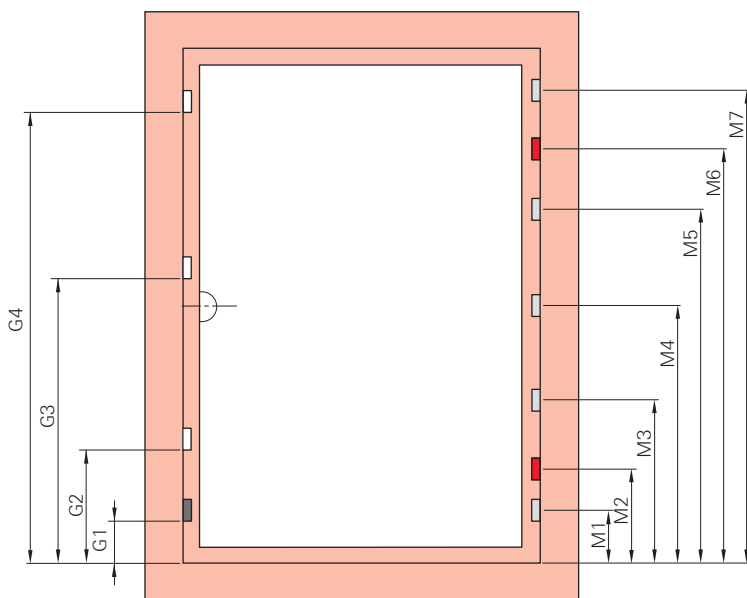

- SEC striker
- SEC striker to prevent incorrect operation
- Mullion security striker
- Striker for anti-pushback function

SEC striker, on the locking side, screw-on

| SRH / mm | G1 | G2 | G3 | G4 |
|-------------|----|-----|--------|--------|
| 1072 - 1300 | 86 | 721 | SRH-13 | - |
| 1301 - 1500 | 86 | 721 | SRH-13 | - |
| 1501 - 1700 | 86 | 721 | SRH-13 | - |
| 1701 - 1900 | 86 | 721 | 1391 | SRH-13 |
| 1901 - 2100 | 86 | 721 | 1391 | SRH-13 |
| 2101 - 2300 | 86 | 721 | 1391 | SRH-13 |
| 2301 - 2500 | 86 | 721 | 1791 | SRH-13 |

SEC MUL striker, on the mullion

| SRH / mm | M1 | M2 | M3 | M4 | M5 | M6 | M7 |
|-------------|-----|-----|----------|----------|---------|---------|---------|
| 1072 - 1300 | 219 | 349 | SRH-478 | - | - | SRH-279 | SRH-149 |
| 1301 - 1500 | 219 | 349 | SRH-683 | - | - | SRH-279 | SRH-149 |
| 1501 - 1700 | 219 | 349 | SRH-843 | SRH-679 | - | SRH-279 | SRH-149 |
| 1701 - 1900 | 219 | 349 | SRH-1083 | SRH-679 | - | SRH-279 | SRH-149 |
| 1901 - 2100 | 219 | 349 | SRH-1279 | SRH-679 | - | SRH-279 | SRH-149 |
| 2101 - 2300 | 219 | 349 | SRH-1483 | SRH-1079 | SRH-679 | SRH-279 | SRH-149 |
| 2301 - 2500 | 219 | 349 | SRH-1679 | SRH-1079 | SRH-679 | SRH-279 | SRH-149 |

9.7.3 Striker, screw-on

9.7.3.1 Preparing the frame for the striker, screw-on



INFO

The marker can be used for sashes that run inward or outward.

In its delivery state, it is suitable for:

- DIN L running inward
- DIN R running outward

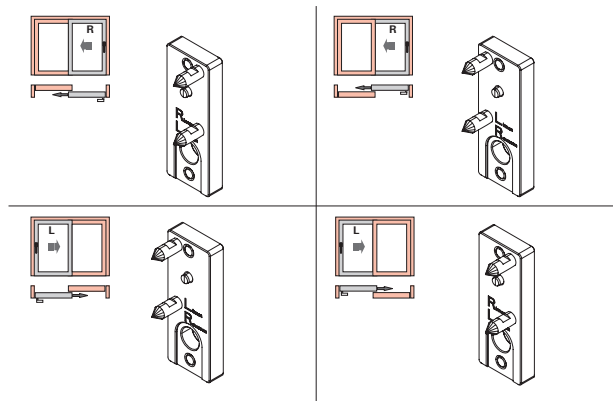

Preparing the marker

1. Unscrew the tip of the marker [1].

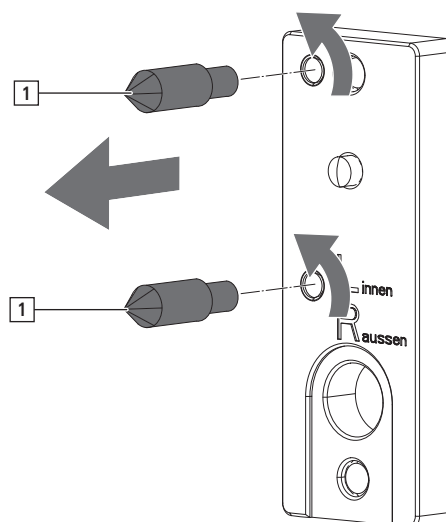



- Turn the marker [2] and reinsert the tip of the marker on the rear.

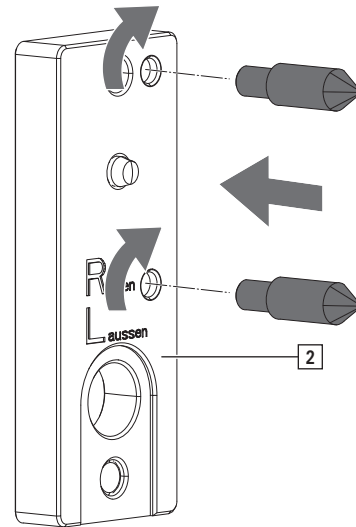

- Tighten the tip of the marker.

**INFO**

The marker is now suitable for:

- DIN R running inward
- DIN L running outward

Marking a position

- Place the markers for strikers, screw-on [1] on the locking side on each locking cam [2].

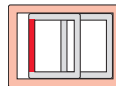
**INFO**

When using the marker to determine the correct drill markings, move the handle to the open position.

The correct position is ensured using a magnet in the marker.

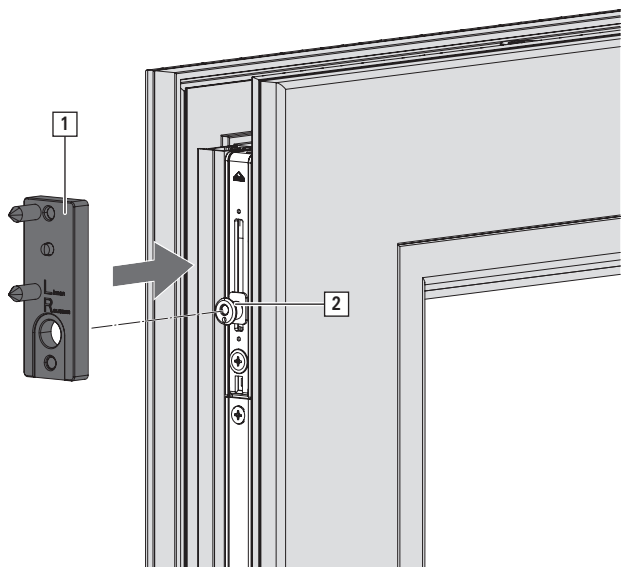
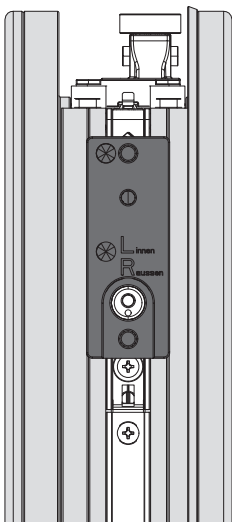

Installation

Joining the sash and frame

Striker, screw-on

2. Close the sash with the marker fitted.

View without sash and hardware:

When closing the sash, the tips of the markers create two marks in the frame profile. These mark the correct drilling position for the striker in question.

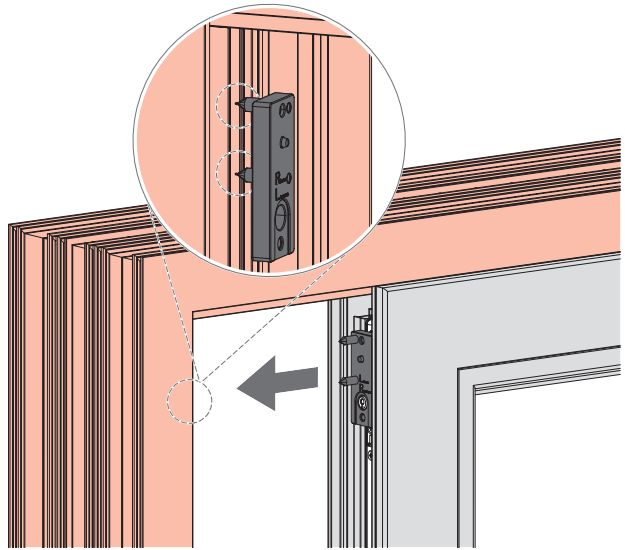



9.7.3.2 Drilling the holes for the striker

Dimensional drawing in open sliding position

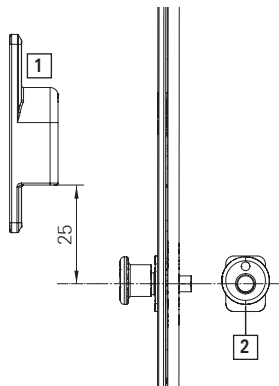

- [1] Striker, screw-on
- [2] Locking cam

1. For the position of the strikers, see the installation drawing → *from page 237*. Alternatively: with marking jig.



INFO

Predrill the frame profile with steel reinforcement.

Drill: 2x Ø 3.5; depth = X

Drill holes.

Drill: 2 x Ø 4.5 mm; depth = Y

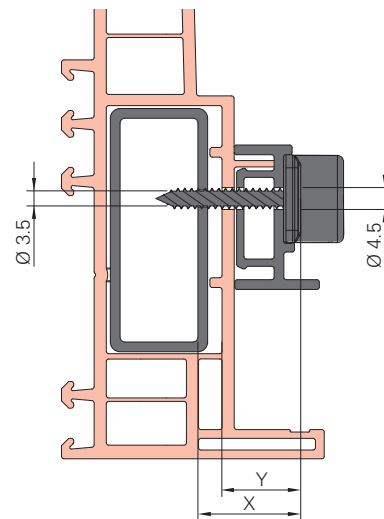
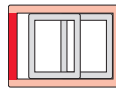

Fig. 9.1: Symmetrical striker

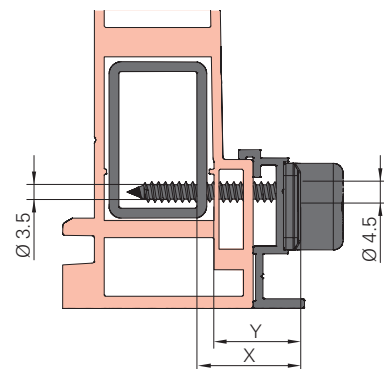

Fig. 9.2: Asymmetrical striker

Installation

Joining the sash and frame

Striker, screw-on

9.7.3.3 Installing the striker

1. Fasten each striker [1] with two screws [2].

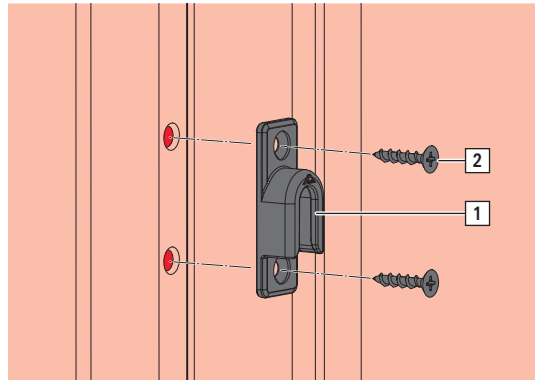
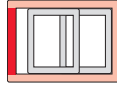

Fig. 9.3: Symmetrical striker

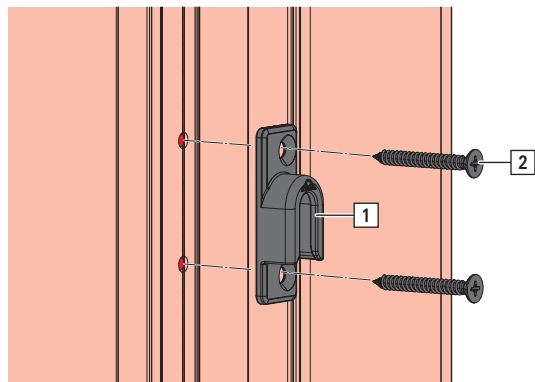

Fig. 9.4: Asymmetrical striker



9.7.4 Striker to prevent incorrect operation

9.7.4.1 Drilling the holes for the striker to prevent incorrect operation

Dimensional drawing in open sliding position

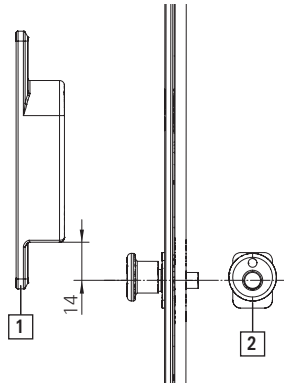

[1] Striker to prevent incorrect operation
[2] Locking cam

1. For the position of the striker to prevent incorrect operation, see the installation drawing.



INFO

Predrill the frame profile with steel reinforcement.

Drill: 2x Ø 3.5; depth = X

Drill holes.

Drill: 2 x Ø 4.5; depth = Y

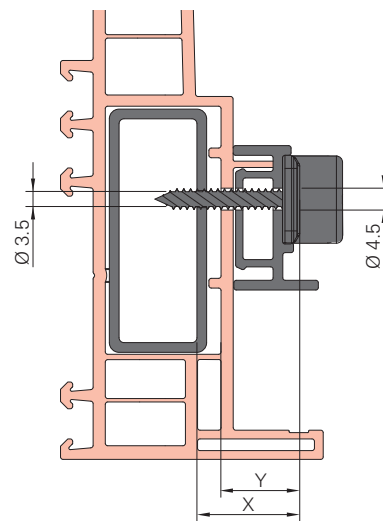
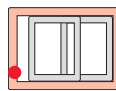

Fig. 9.5: Symmetrical striker

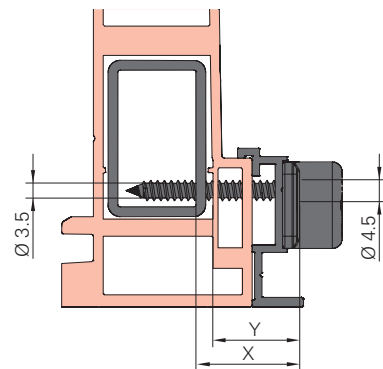
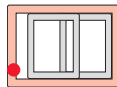

Fig. 9.6: Asymmetrical striker

9.7.4.2 Installing the striker to prevent incorrect operation

1. Fasten the striker to prevent incorrect operation [1] with two screws [2].



INFO

Note the drilling specifications → 9.7.4.1 “Drilling the holes for the striker to prevent incorrect operation” from page 217.

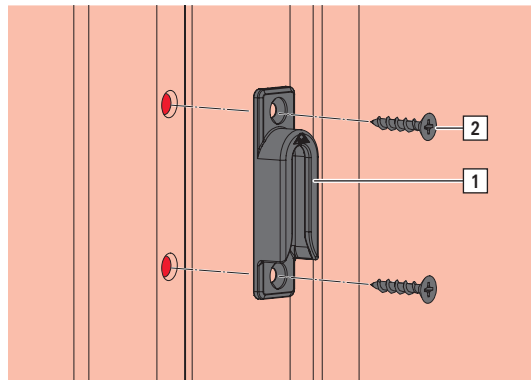

Fig. 9.7: Symmetrical striker to prevent incorrect operation

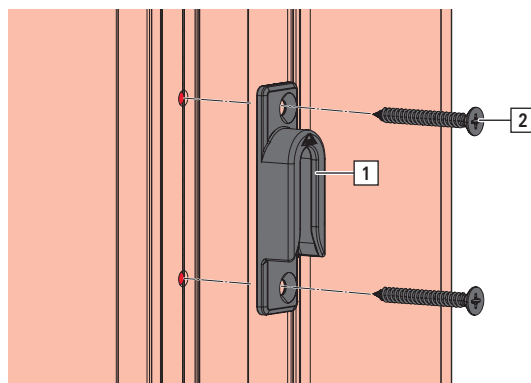

Fig. 9.8: Asymmetrical striker to prevent incorrect operation



9.7.5 MUL striker

9.7.5.1 Drilling the holes for the mullion striker

1. Place the drilling jig for the mullion striker [1] flush against the frame profile at the height of the locking cam [2]. Mark the position of the drilling jig.

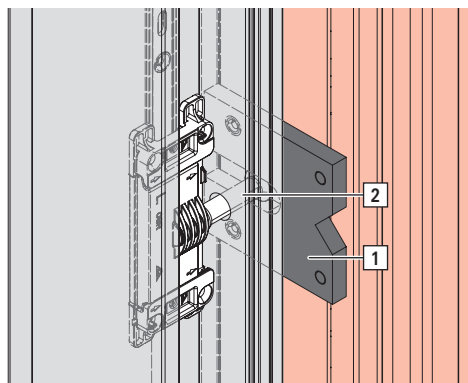
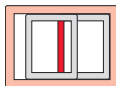

2. Drill the holes [3].
Drill: timber \varnothing 3.0; PVC \varnothing 3.5

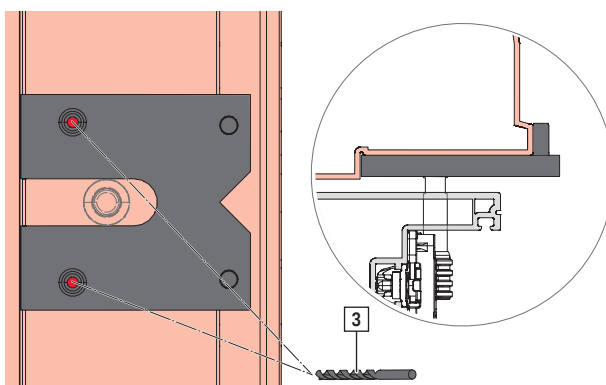

9.7.5.2 Installing the mullion striker

1. Fasten the mullion striker [1] with two screws [2].

**INFO**

Note the drilling specifications → 9.7.5.1 "Drilling the holes for the mullion striker" from page 219.

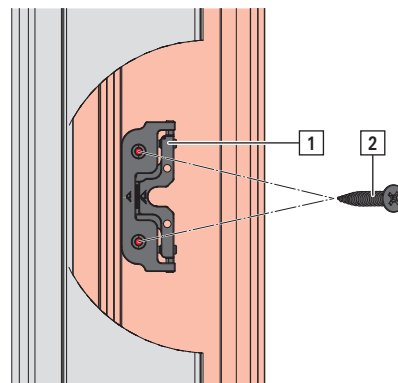
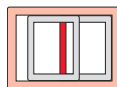

2. Clip the cover cap [3] onto the mullion striker.

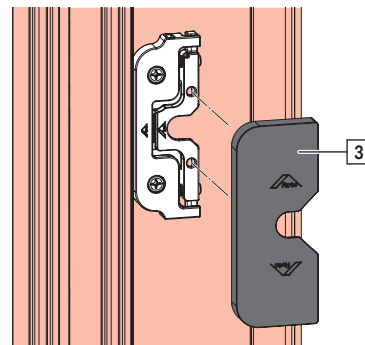

9.7.6 SEC MUL striker

9.7.6.1 Drilling the holes for the mullion security striker

1. Place the mullion security striker drilling jig [1] flush against the frame profile at the height of the locking cam [2] as shown. For better guidance, move the sash with locking cam fitted in the direction of the arrow.

Drill the holes [3].

Drill: timber Ø 3.0; PVC Ø 3.5

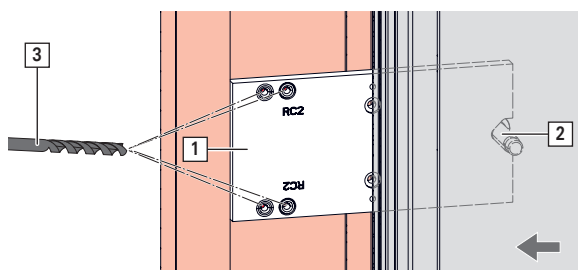
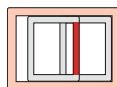



9.7.6.2 Installing the SEC MUL striker

1. Secure the SEC MUL striker [1] with four screws [2].

**INFO**

Note the drilling specifications →
9.7.6.1 "Drilling the holes for the mullion security striker" from page 220.

Clip the cover cap [3] onto the SEC MUL striker.

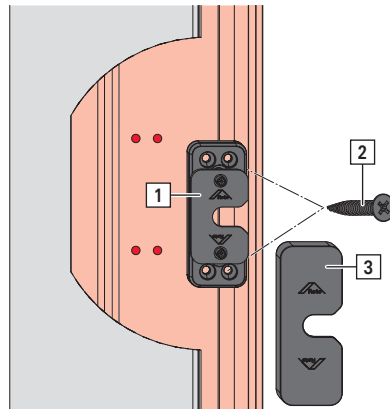
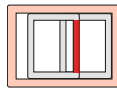

9.7.7 Striker for anti-pushback function

Installing the striker for anti-pushback function

1. Place the drilling jig for the striker for anti-pushback function [1] flush against the frame profile at the height of the pin [2]. For better guidance, move the sash with pin fitted in the direction of the arrow.

Drill the holes [3].

Drill: timber \varnothing 3.0; PVC \varnothing 3.5

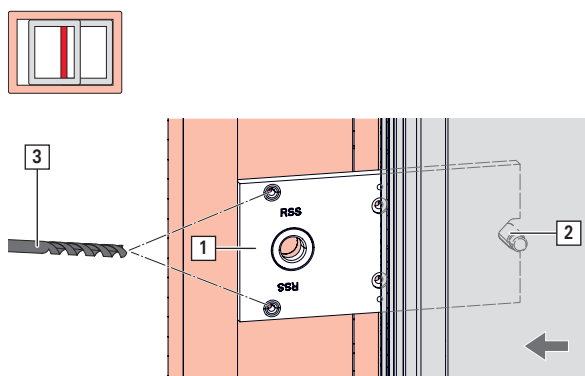

2. Drill the hole [4].

Drill: \varnothing 12.5 mm

**INFO**

Refer to the system-specific profile assessment for the drilling depth.

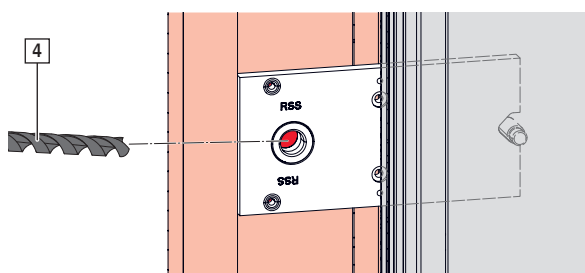

3. Fasten the striker for anti-pushback function [5] with two screws [6].

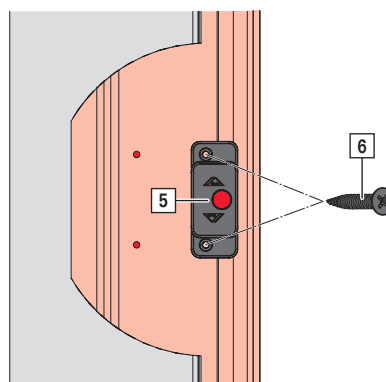

4. Clip the cover cap [7] onto the striker for anti-pushback function.

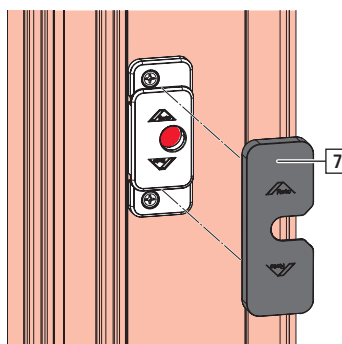



9.7.8 Activator and packer

⇒ The control unit with soft function comes assembled in its delivery state (= untensioned).

⇒ The element is glazed.

9.7.8.1 Preparing the positioning jig

Determining the quantity of packers

1. Calculate or refer to the profile assessment for the quantity of packers required [1].

$$\text{Quantity of packers} = (Y - 38) / 2$$

Maintain a distance of 27.5 ± 1 mm between the highest point of the activator [2] and the control unit supporting surface.

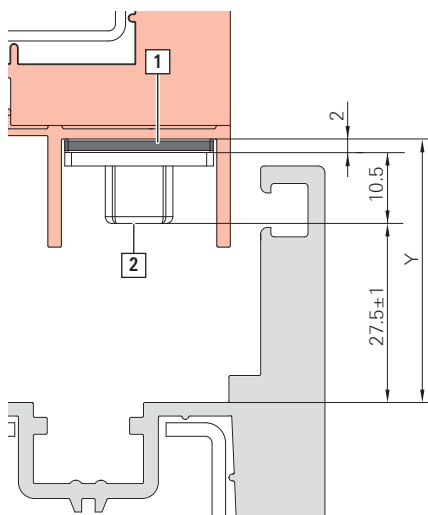

Adjusting and equipping the positioning jig for the activator with a centre screw fixing

On the locking side for control unit with SoftClose

- 1 Adjust the screw [1] on the "SoftClose" side (X = profile-related).
- 2 If necessary, connect the packer to the activator using locating aids. Ensure that the slots are aligned.
- 3 Place everything in the positioning jig mount. The activator bolt [2] is facing towards the "SoftOpen" text.
- 4 Insert the drilling aid [3] into the positioning jig.

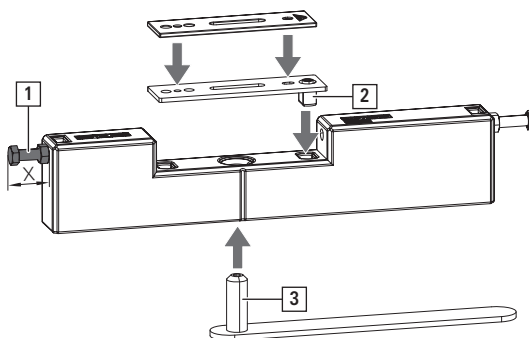

On the mullion side for control unit with SoftOpen

- 1 Adjust the screw [1] on the "SoftOpen" side (X = profile-related).
- 2 If necessary, connect the packer to the activator using locating aids. Ensure that the slots are aligned.
- 3 Place everything in the positioning jig mount. The activator bolt [2] is facing towards the "SoftClose" text.
- 4 Insert the drilling aid [3] into the positioning jig.

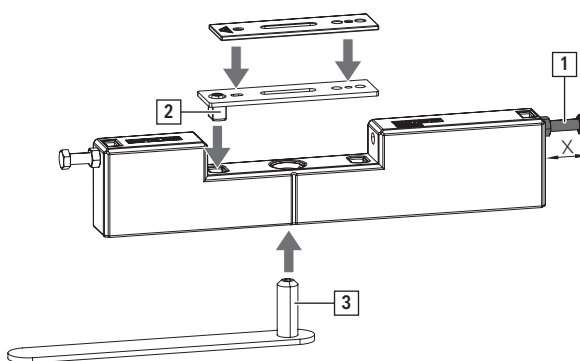

Installation

Joining the sash and frame

Activator and packer

Control unit with SoftStop

Prepare SoftClose or SoftOpen accordingly, depending on the installation situation.

Adjusting and equipping the positioning jig for activator with an asymmetrical screw fixing

On the locking side for control unit with SoftClose

- 1 Adjust the screw [1] on the "SoftClose" side (X = profile-related).
- 2 Align the positioning jig so that the drilling aid mount [2] is facing towards the side on which the holes were drilled for the activator.
- 3 If necessary, connect the packer to the activator using locating aids. Ensure that the slots are aligned.
- 4 Place everything in the positioning jig mount. The activator bolt [3] is facing towards the "SoftOpen" text.
- 5 Insert the drilling aid into the positioning jig.

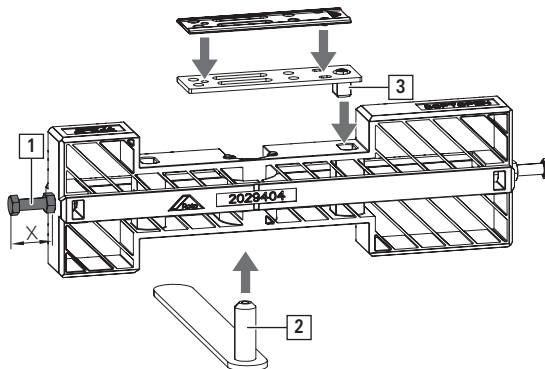

On the mullion side for control unit with SoftOpen

- 1 Adjust the screw [1] on the "SoftOpen" side (X = profile-related).
- 2 Align the positioning jig so that the drilling aid mount [2] is facing towards the side on which the holes were drilled for the activator.
- 3 If necessary, connect the packer to the activator using locating aids. Ensure that the slots are aligned.
- 4 Place everything in the positioning jig mount. The activator bolt [3] is facing towards the "SoftClose" text.
- 5 Insert the drilling aid into the positioning jig.

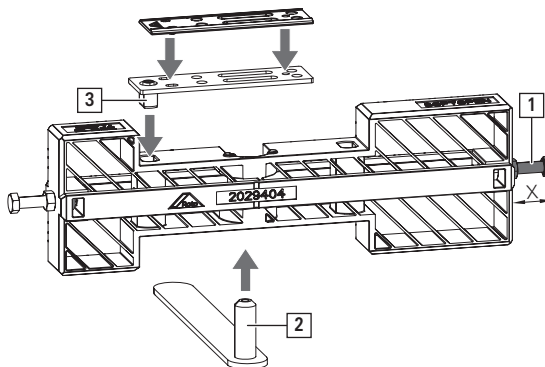

9.7.8.2 Diagram A



INFO

Pay attention to the profile assessment.

Installation without a positioning jig

Installing the activator with / without packer(s) on the locking side

1. Pre-drill a hole for the screw [1] (for dimensions X and Y, see the profile assessment).

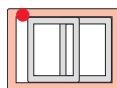

If necessary, connect the packer to the activator using locating aids. Ensure that the slots are aligned.

Slightly tighten the activator with one screw to position it so that the activator can still be moved. The activator bolt [2] is facing towards the centre of the access area.

Close the sash slowly and open it again to move the activator into the installation position.

Pre-drill the holes for screws [3].



Fasten the activator with three screws.

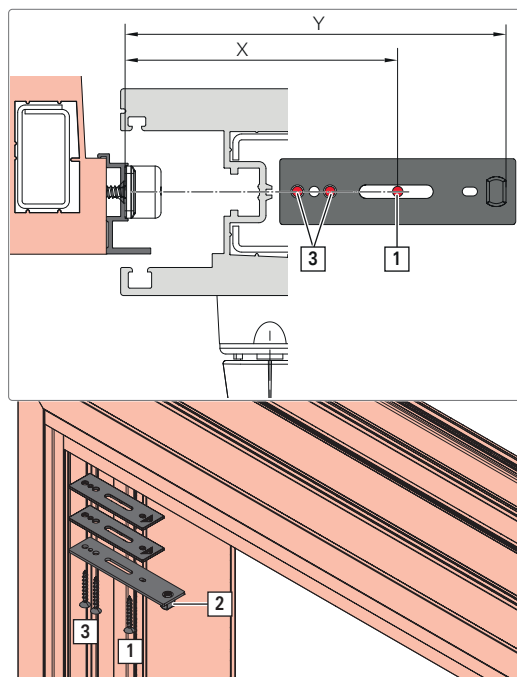

Fig. 9.9: Activator and packers with a centre screw fixing

Installing the activator with / without packer(s) on the mullion side

1. Pre-drill a hole for the screw [1] (for dimension Z, see the profile assessment).

Slightly tighten the activator with one screw to position it (for dimension Y, see the profile assessment) so that the activator can still be moved. The activator bolt is facing towards the centre of the access area.

Slowly open the sash fully and close it again to move the activator into the installation position. Pre-drill the holes for screws [2].

Fasten the activator with three screws.

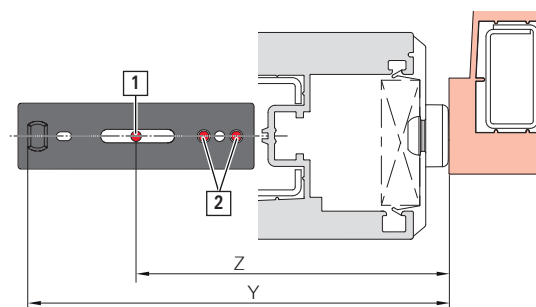
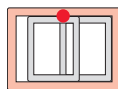

Fig. 9.10: Activator and packers with a centre screw fixing



INFO

Control unit with SoftOpen: if the sash should not hit the buffer, move the activator screw position by at least 21 mm ($Z + 21$ and $Y + 21$).

Installation with a positioning jig

Installing the activator with / without packer(s) using a positioning jig on the locking side

1. Insert the equipped positioning jig into the operator track and push the screw head of the adjusting screw onto the frame on the locking side until it reaches the stop.

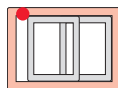

Pre-drill through the drilling aid with a $\varnothing 3.5$ drill [A].

Remove the drilling aid.

Slightly tighten the activator with one screw [5] through the positioning jig to position it so that the activator can still be moved.

Installation

Joining the sash and frame

Activator and packer

Remove the positioning jig.

Close the sash slowly and open it again to move the activator into the installation position.

Predrill the holes for screws [6] in the same screw axis as the first screw.

Fasten the activator with three screws.

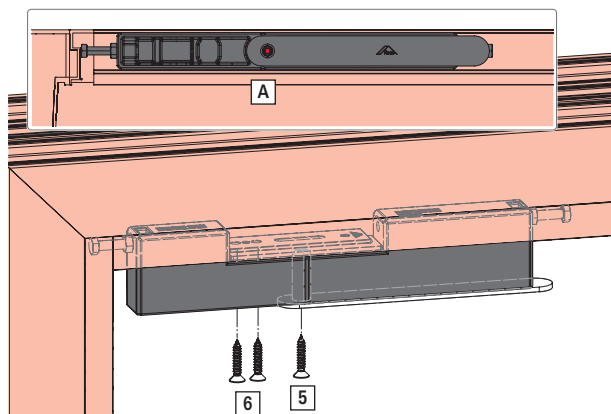

Fig. 9.11: Activator and packers with a centre screw fixing

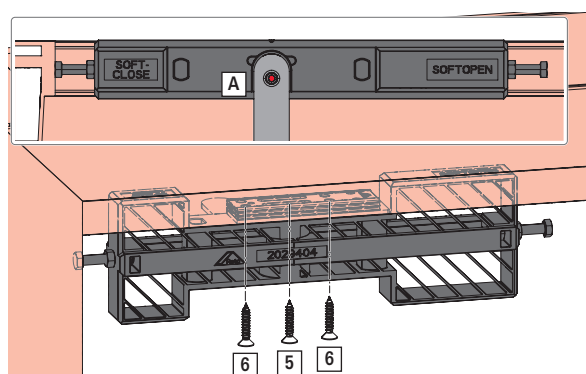

Fig. 9.12: Activator and packers with an asymmetrical screw fixing

Installing the activator with / without packer(s) using a positioning jig on the mullion side

1. Insert the equipped positioning jig into the operator track. Push the screw head of the adjusting screw onto the frame on the mullion side until it reaches the stop.

Predrill through the drilling aid with a \varnothing 3.5 drill [A].

Remove the drilling aid.

Slightly tighten the activator with one screw [5] through the positioning jig to position it so that the activator can still be moved.

Remove the positioning jig.

Close the sash slowly and open it again to move the activator into the installation position.

Predrill the holes for screws [6] in the same screw axis as the first screw.

Fasten the activator with three screws.

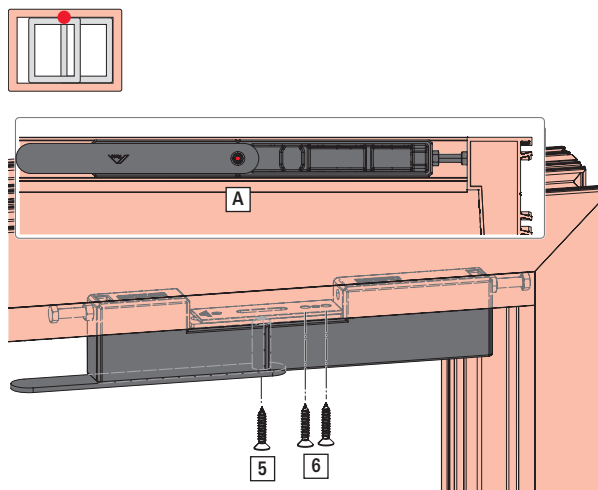

Fig. 9.13: Activator and packers with a centre screw fixing

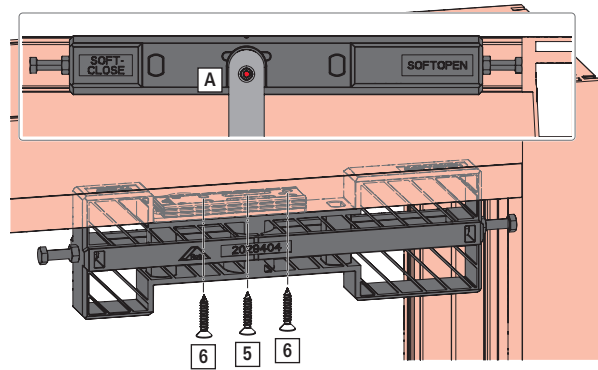
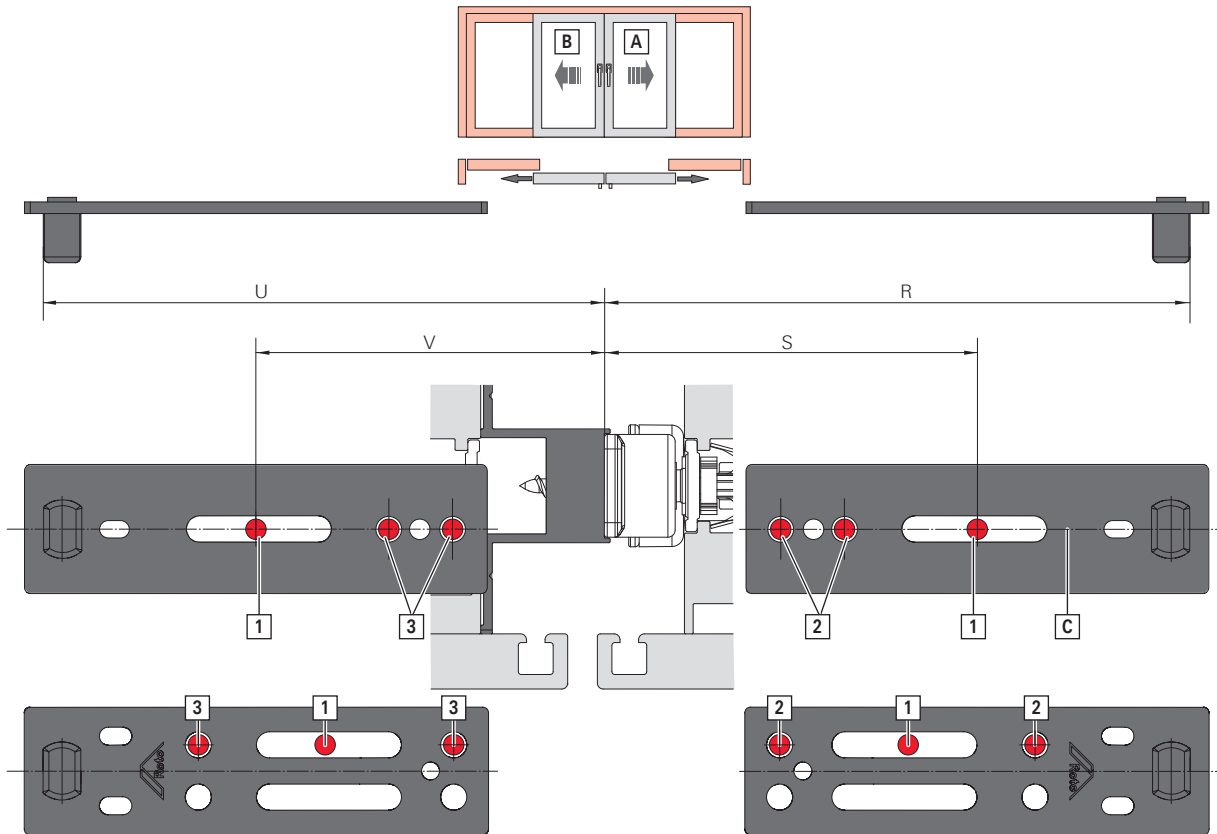

Fig. 9.14: Activator and packers with an asymmetrical screw fixing

9.7.8.3 Diagram C



- [A] First opening sash
- [B] Second opening sash
- [C] Centre of guide groove in the operator track

1. Connect the packers to the activator using locating aids. Ensure that the slots are aligned.
 Pre-drill a hole for the screw [1] (for the first opening sash to dimension S, for the second opening sash to dimension V, see profile assessment). Slightly tighten every activator with one screw each to position them (for dimensions R and U, see the profile assessment) so that the activator can still be moved.
 Close the second opening sash [B] slowly and open it again to move the activator into the installation position.
 Pre-drill the holes for screws [2].
 Fasten with three screws.
 Close the second opening sash and move the handle to the closed position.
 Close the first opening sash [A] slowly and open it again to move the activator into the installation position.

Installation

Joining the sash and frame

Tensioning the control unit with soft function

Predrill the holes for screws [3].

Fasten with three screws.

9.7.9 Tensioning the control unit with soft function



CAUTION

Risk of injury caused by tensioning the control unit with soft function by hand.

When installing the control unit with soft function, tensioning by hand may cause injuries due to sharp edges.

1. Only tension the control unit with soft function using a tensioning tool.

1. Mount the tensioning tool recess [1] in the activator bolt [2].
Push the element shut slowly until the connector [3] on the tensioning tool engages in the control unit with soft function.

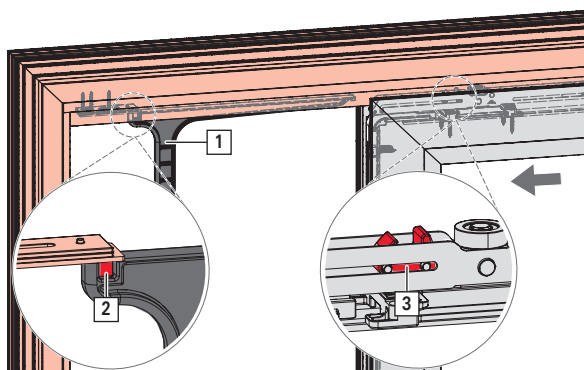

2. Open up the element slowly to activate the soft function. The connector on the tensioning tool will be released automatically.



9.7.10 Tilt protection device



DANGER

The uncontrolled tilting of sashes with aspect ratios > 2:1 poses a risk of death!

Uncontrolled tilting may cause sashes with aspect ratios > 2:1 to jump out of the operator track. This may lead to hazardous situations and cause serious or fatal accidents.

- ▶ The roller track must have two walls → 3.6 "Dimensions of the roller track" from page 30.
- ▶ Install the tilt protection device (only without control unit with Soft function) → 3.7 "Dimensions of the tilt protection device" from page 30.
- ▶ An installation space examination is a mandatory part of a profile assessment.



ATTENTION

Premature installation may cause property damage.

If the tilt protection device is installed before the sash and frame are joined, this can damage the installed hardware.

1. Only install the device once the sash and frame have been joined.



INFO

Example diagram.

Drilling patterns are profile-related (available upon request).

Preparing the drilling jig

For use on the locking side

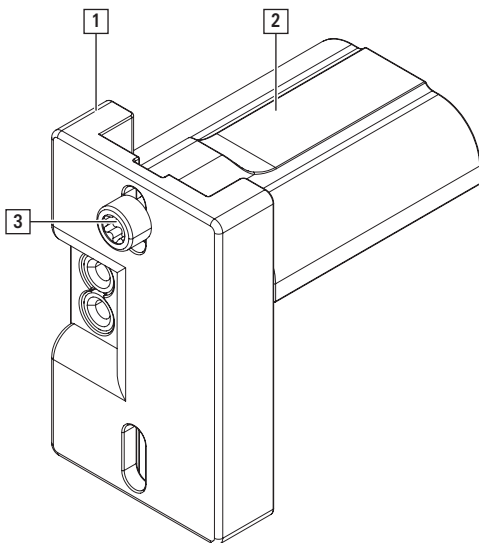

For use on the mullion side

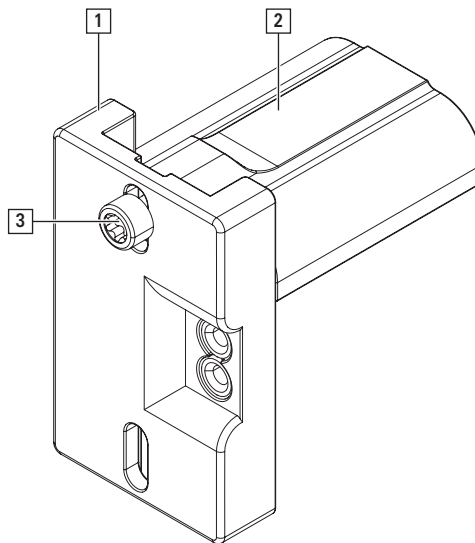

1. Detach the drilling plate [1] from the stop [2] by loosening the screw [3].
2. Turn the drilling plate 180°.
3. Fasten the drilling plate to the stop with one screw.

Installation

Joining the sash and frame

Tilt protection device

Drilling the holes for the tilt protection device

1. Open the sash.

Loosen the screw [1] on the drilling plate [2].

Position the drilling jig on the corner of the sash at the top on the locking side.

- **Inward running sashes:** position the drilling jig so that the side with the drill holes is facing **away** from the handle.
- **Outward running sashes:** position the drilling jig so that the side with the drill holes is facing **towards** the handle.

Push the drilling plate up until it reaches the stop on the operator track [3].

Fasten the drilling plate with a screw again.

Align the drilling jig so that it is centred relative to the hardware and drill through two walls.

Drill: 2 x Ø 3.5



INFO

Screw lengths are profile-related.

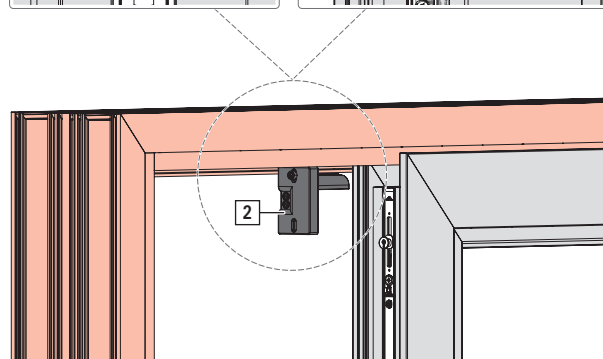
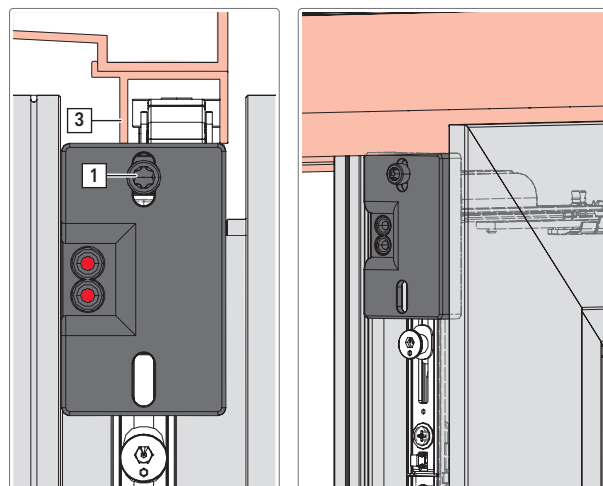

Installing the tilt protection device

⇒ The adapter profile (if present) is routed → *from page 169*.

⇒ The adapter profile stops flush with the sash rebate.

1. Fasten the tilt protection device with two screws through two walls.

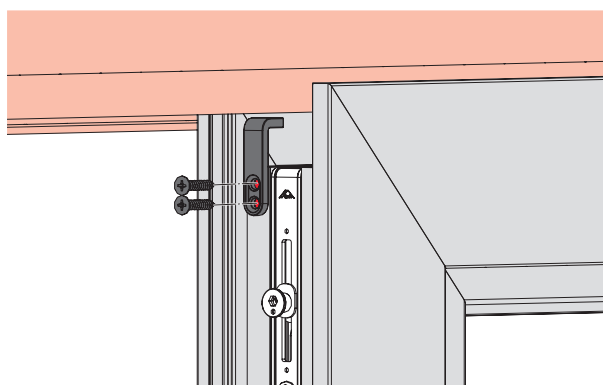



9.7.11 Buffer

9.7.11.1 Drilling the holes for the buffer

Installation drawing in open sliding position

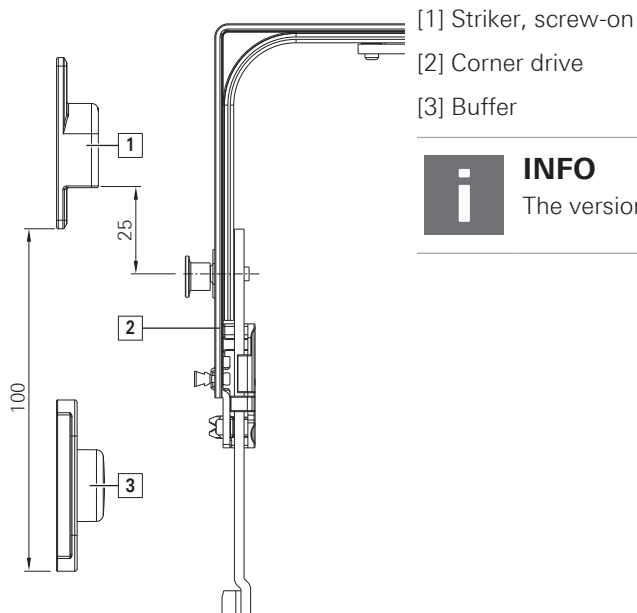

INFO

The version on the bottom is mirror-inverted.

1. Drill holes.



INFO

Predrill the frame profile with steel reinforcement.

Drill: 2x Ø 3.5; depth = X

Drill: 2 x Ø 4.5; depth = Y

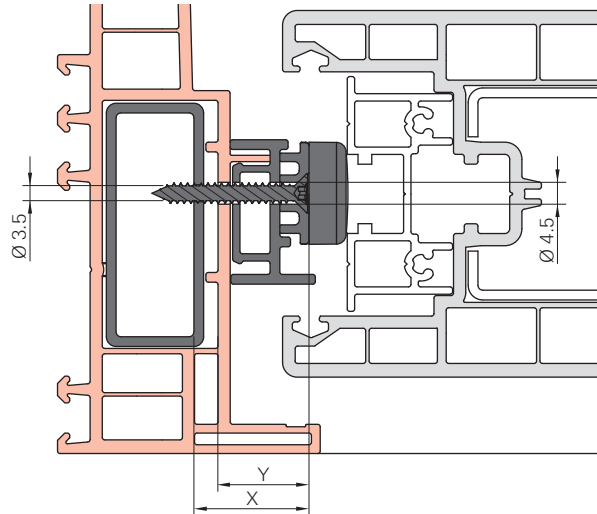

9.7.11.2 Installing the buffer

1. Fasten each buffer [1] with two screws [2].



INFO

Note the drilling specifications → 9.7.11.1 "Drilling the holes for the buffer" from page 231.

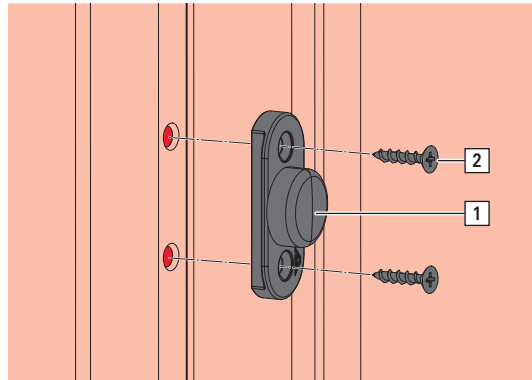
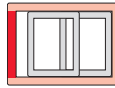

Exception: timber, diagram C'

1. Align the buffer [1] horizontally and fasten with two screws [2].

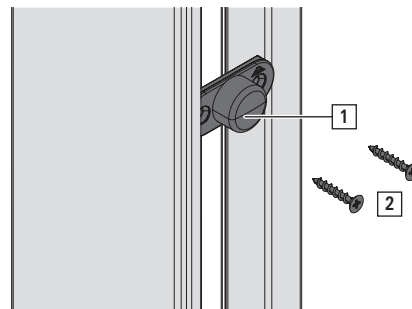
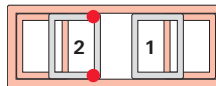



9.7.12 End stop with packer

1. Adapt the end stop and, if necessary, the end stop packer on a profile-related basis.

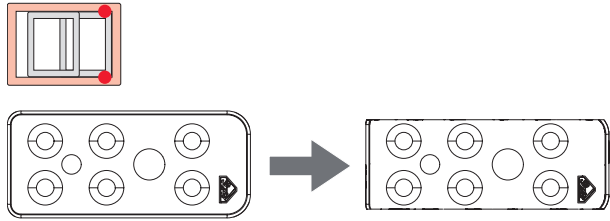

2. Place the end stop packer [1] on the roller track [2] and fasten with screws.

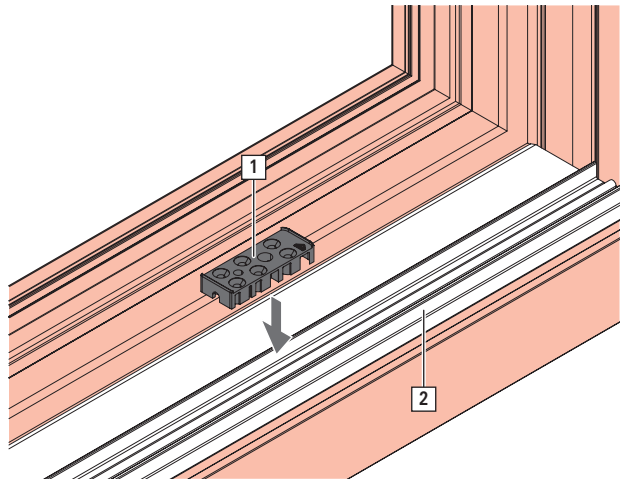

3. Drill the holes for the end stop.
 [A]: $\text{Ø } 8.0+0.2$ (1x)
 [B]: predrill $\text{Ø } 3.0$ (1x)

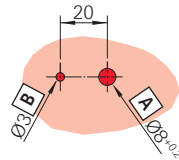

4. Install the rubber buffer [3] in the end stop [4], position it on a packer, and fasten with a screw [5].

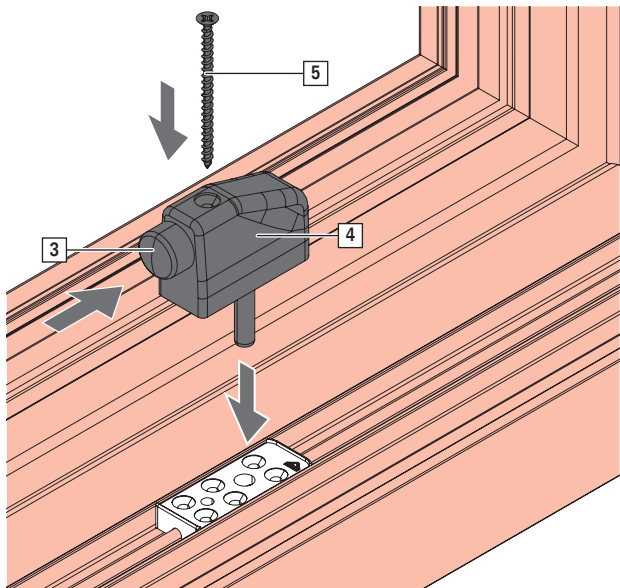

9.7.13 Operator track stopper

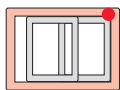

INFO

Pay attention to the profile assessment.

Installation without a positioning jig

1. If necessary, connect the packer [1] to the stopper [2] using locating aids. Ensure that the slots are aligned.
 Pre-drill a hole for the screw [3] (dimension X can be freely selected).
 Slightly tighten the stopper with one screw to position it so that the stopper can still be moved. The stopper buffer side is facing towards the centre of the access area.
 Open the sash slowly and close it again to move the stopper into the installation position.
 Pre-drill the holes for screws [4].
 Fasten the stopper with three screws.

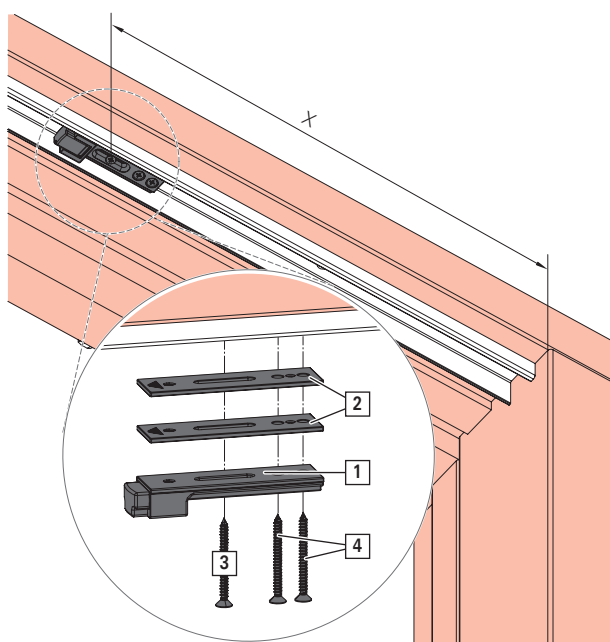

Installation with a positioning jig

Installing the operator track stopper, diagram A

1. Adjust the screw [1] (dimension X can be freely selected).
 If necessary, connect the packer [2] to the stopper [3] using locating aids. Ensure that the slots are aligned.
 Place everything in the positioning jig mount.
 Insert the drilling aid [4] into the positioning jig.

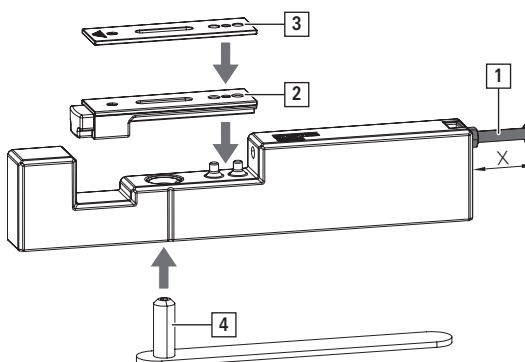

Fig. 9.16: Stopper and packers with a centre screw fixing

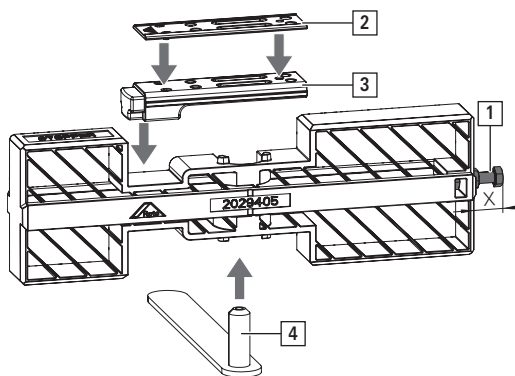

Fig. 9.17: Stopper and packers with an asymmetrical screw fixing

2. Insert the equipped positioning jig into the operator track and push the screw head of the adjusting screw onto the frame until it reaches the stop.

Pre-drill through the drilling aid with a \varnothing 3.5 drill [A].

Remove the drilling aid.

Slightly tighten the stopper with one screw [5] through the positioning jig to position it so that the stopper can still be moved.

Open the sash slowly and close it again to move the stopper into the installation position.

Pre-drill the holes for screws [6].

Fasten the stopper with three screws.

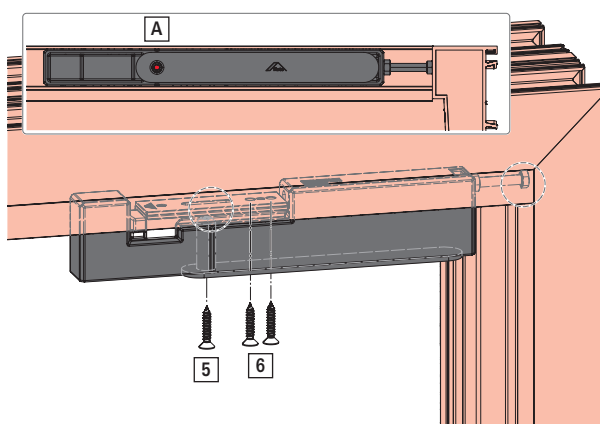

Fig. 9.18: Stopper and packers with a centre screw fixing

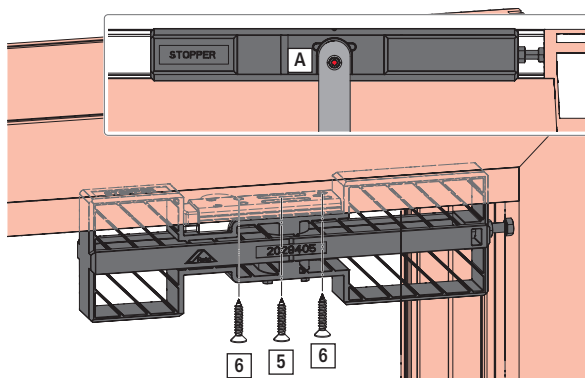

Fig. 9.19: Stopper and packers with an asymmetrical screw fixing

Installing the operator track stopper, diagram C

⇒ The second opening sash is on the bench: mark the position of the roller outer edge of the control unit on the espagnolette side [A].

1. Close the second opening sash.

Transfer the marking for the "position of the roller outer edge of the control unit" from the sash to the frame and move it 82 mm towards the espagnolette side [B].

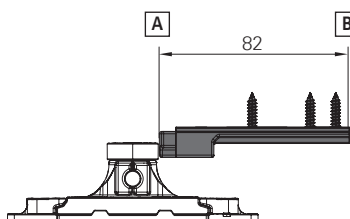

Installation

Joining the sash and frame

Notes on final assembly

2. Insert the stopper [1] and, if required, packers [2] into the operator track.
Move the stopper up to the marking [B].
Fasten loosely with one screw [3] but so that it is not yet secure.
Check the stopper position and reposition if necessary.
Fasten the stopper with three screws.

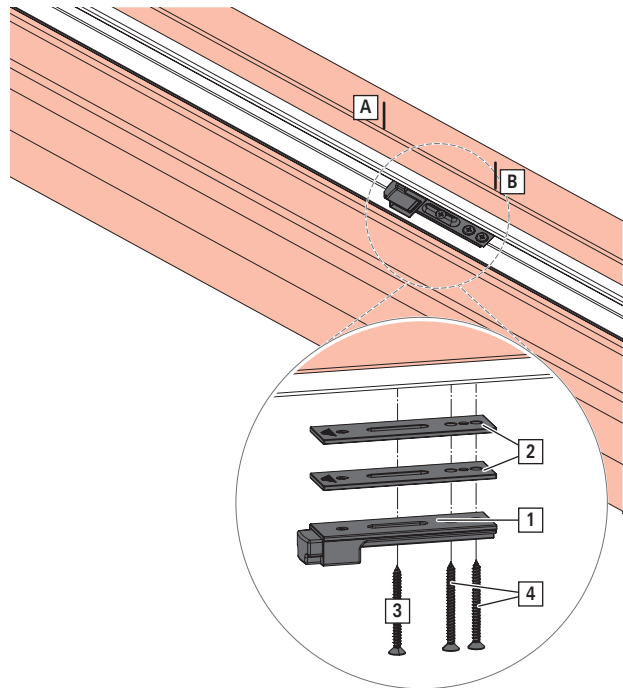

9.7.14 Notes on final assembly



DANGER

Risk of death caused by excessive bending of the running profile.

Incorrect installation of the sash in an element that bends by ≥ 3 mm may cause the sash to fall out.

1. Underlay the element so that it bends by < 3 mm.



INFO

In order to ensure that the element works properly and is safe, the bending of the frame must not exceed 3 mm.



INFO

Place supports uniformly under the threshold across its entire area (spaced max. 300 mm apart, profile-related).

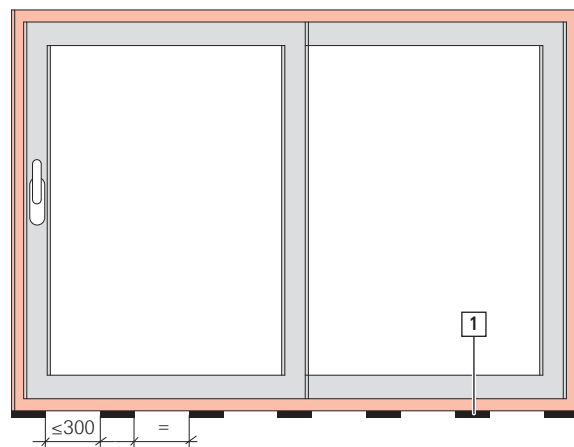
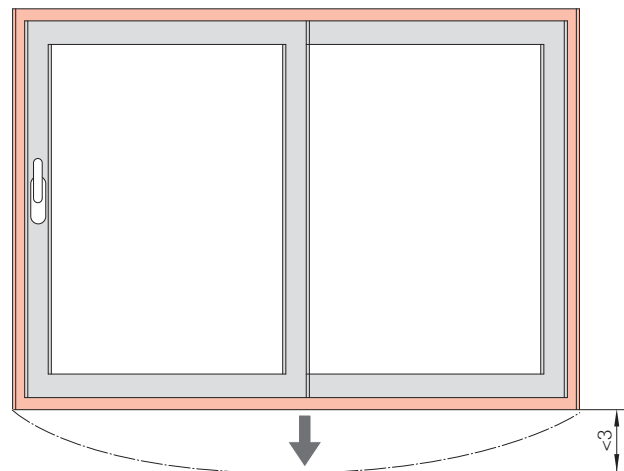

[1] Packer



10 Installation drawings

10.1 Explanation

The following markings are used in the installation drawings to emphasise references and other elements:

| Marking | Meaning |
|------------------------------|--|
| 3.Laufwagen ab FFB >1061 | Third roller unit from SRW > 1061 mm |
| 3.Steuereinheit ab FFB >1061 | Third control unit from SRW > 1061 mm |
| aktiv | First opening |
| Ansicht von innen | View from inside |
| Ausfuehrung | Version |
| aussen laufend | Running outward |
| Beschlagteile links | Hardware components, left |
| Beschlagteile rechts | Hardware components, right |
| FFB | Sash rebate width |
| Fehlbed.-Schliessstueck RC2 | SEC striker to prevent incorrect operation |
| FFH | Sash rebate height |
| Garnitur-Positionierung | Set positioning |
| innen laufend | Running inward |
| min | Minimum |
| max | Maximum |
| passiv | Second opening |
| Puffer | Stop |
| RC 2 / RC 2 N | RC 2 / RC 2 N |
| Rueckschiebesicherung | Anti-pushback function |
| Schaltfolgeregelung | Operating sequence control |
| Schema A | Diagram A |
| Schema A' | Diagram A' |
| Schema C | Diagram C |
| Schema C' | Diagram C' |
| Schliessstueck RC2 | RC 2 striker |
| Schliessteile | Locking components |
| Standard | Standard |
| Standardausfuehrung | Standard version |



11 Adjustment



INFO

Roto hardware components may only be adjusted by authorised professionals when the element is installed.

11.1 Striker

Lateral and height adjustment

1. Close the window sash (open handle position).
2. Adjust the striker [1] using two threaded pins [2] in the fastening plate.
Tool: size 2.5 hex key.



INFO

The striker features variable height adjustment, which permits an installation tolerance of ± 3 mm for the locking cam.

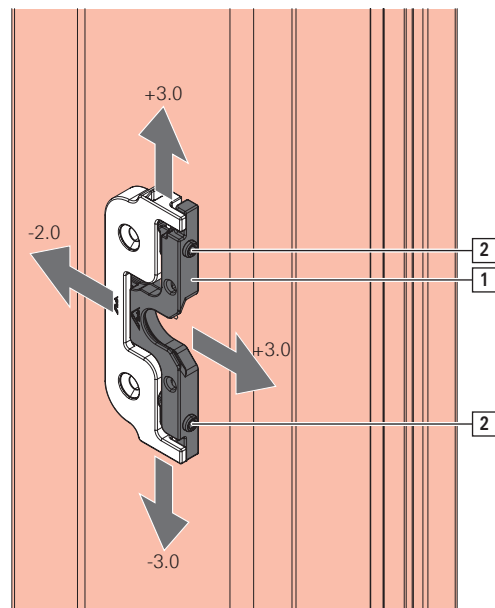

11.2 Adjusting the locking cam

E cam

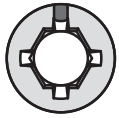
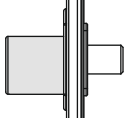
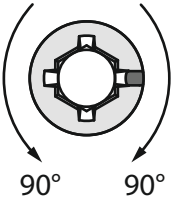
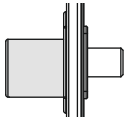
| E cam | Adjustment distance | Gasket compression adjustment [mm] | Height | Side view |
|---|--|------------------------------------|--------|---|
|  | | | |  |
| |  90° 90° | ± 0.8 | |  |

Adjustment

MUL locking cam / pin for anti-pushback function – adjustable

V cam

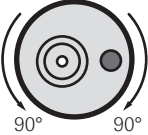
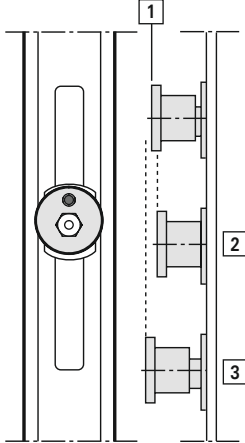
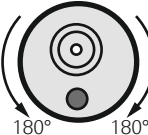
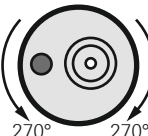
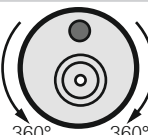
| V cam | Adjustment distance | Gasket compression adjustment [mm] | Height adjustment [mm] | Side view |
|---|---------------------|---------------------------------------|------------------------|--|
|  | | | | |
|  90° 90° | ±0.8 | | ±0.2 |  <p>[1] 0 = initial position [2] -0.8 mm max. adjustment [3] +0.8 mm max. adjustment</p> |
|  180° 180° | | | ±0.4 | |
|  270° 270° | ±0.8 | | ±0.6 | |
|  360° 360° | | | ±0.8 | |

11.3 MUL locking cam / pin for anti-pushback function – adjustable



INFO

Roto hardware components may only be adjusted by authorised qualified personnel.

Adjustment

MUL locking cam / pin for anti-pushback function – adjustable



Gasket compression adjustment

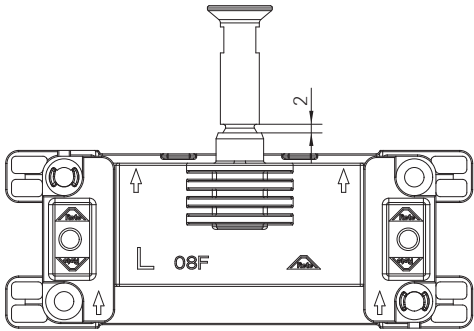

Initial position

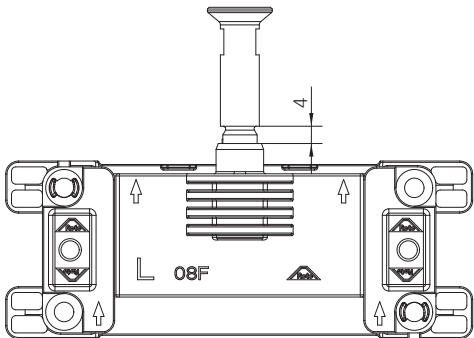
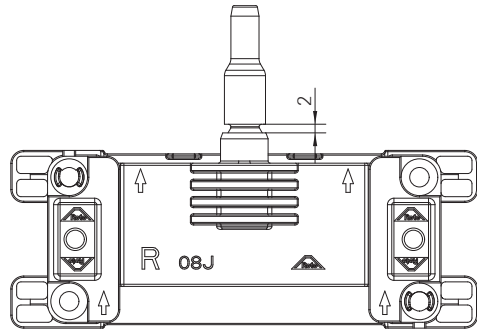

+2,0

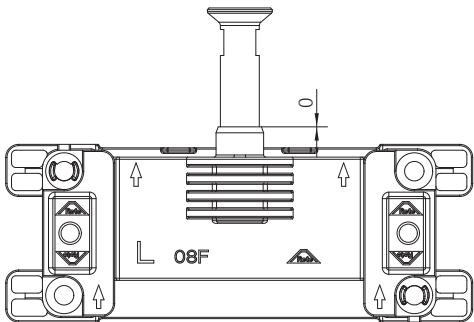
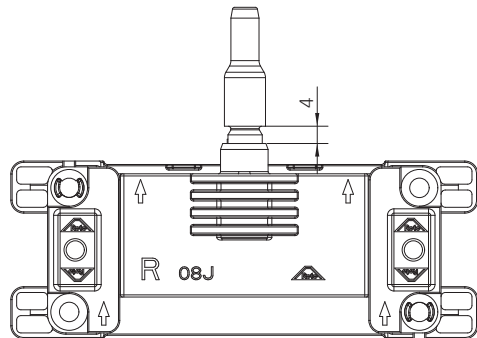

-2,0

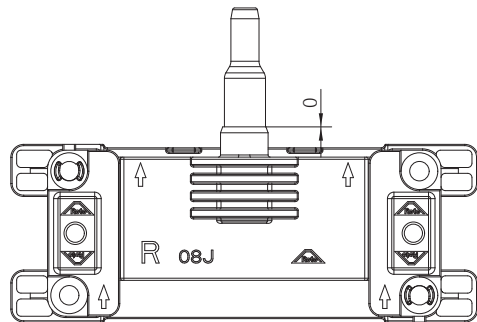

12 Operation

12.1 Operating information

The windows and balcony doors are operated using a handle.

The following symbols illustrate the different handle positions and the resultant sash positions of the windows and balcony doors.

12.1.1 Roto Patio Inowa



ATTENTION

Risk of being accidentally locked out.

If the sash is in the sliding position and closes, the sash can engage and then be impossible to reopen from the outside.

- ▶ Secure the sash against accidentally engaging when in the sliding position.
- ▶ Ensure that access is possible if necessary.

| Handle position | Sash position | Meaning |
|-----------------|---------------|----------------------------------|
| | | Sash in closed position. |
| | | Sash in open sliding position. |
| | | Sash in closed sliding position. |

12.2 Fault assistance

| Fault | Cause | Corrective action | To be carried out by |
|---|--|---|--------------------------|
| Handle is difficult to turn. | Frame components have not been greased. | Grease the frame components. | <input type="checkbox"/> |
| | Handle is damaged. | Replace the handle. | ■ |
| | Handle screwed into place too tightly. | Undo the screw fixing slightly. | ■ |
| | Sash components with slanting screws. | Screw the sash components in straight. | ■ |
| | Sash components are damaged. | Replace the sash components. | ■ |
| | Incorrect striker positions. | Adapt the striker positions. | ■ |
| Handle cannot be turned 180°. | Sash components hinged or installed incorrectly. | Check the setting in the turn position (potentially rehanging – start from the T&T espagnolette). | ■ |
| | | Check the connecting rod and replace if necessary. | |
| Locking cams brush against the striker. | Sash components hinged or installed incorrectly. | Check the setting in the turn position (potentially rehanging – start from the T&T espagnolette). | ■ |
| | | Incorrect striker positions. | |

= May be carried out by a specialist company or the end user

■ = **Must** be carried out by a specialist company



13 Maintenance



CAUTION

Performing maintenance work incorrectly can lead to injuries.

Performing maintenance incorrectly can lead to injuries.

- ▶ Ensure that there is sufficient space for installation before starting work.
- ▶ Ensure that the installation site is clean and tidy.
- ▶ Always have hardware adjustment and replacement work performed by a specialist company.
- ▶ Secure the sash against unintentionally opening or closing.
- ▶ Do not unhinge the sash for maintenance.



ATTENTION

Incorrect or improper testing may cause property damage.

Incorrect or improper testing of the hardware may cause the element to malfunction.

- ▶ Have the hardware checked by a specialist company when installed.
- ▶ If defects need to be remedied, have the element unhinged and remounted by a specialist company.



INFO

The manufacturer must draw the attention of builders and end consumers to these maintenance instructions.

Roto Frank Fenster- und Türtechnologie GmbH recommends the manufacturer conclude a maintenance agreement with their end users.

No legal claims can be derived from the following recommendations; their application is to be based on the specific individual case.

| | Responsibility | |
|--|-------------------------------------|-----------------|
| Maintenance interval | <input type="checkbox"/> | → from page 245 |
| Cleaning | | → from page 246 |
| Clean hardware | <input type="checkbox"/> | |
| Care | | → from page 246 |
| Lubricate movable parts | <input type="checkbox"/> | |
| Lubricate locking points | <input type="checkbox"/> | |
| Performance test | | |
| Check that hardware components are fitted securely | <input type="checkbox"/> | |
| Inspect hardware components for wear | <input type="checkbox"/> | |
| Check that movable parts work properly | <input type="checkbox"/> | |
| Check that locking points work properly | <input type="checkbox"/> | |
| Check ease of movement | <input checked="" type="checkbox"/> | |
| Repair | | → from page 248 |
| Retighten screws | <input checked="" type="checkbox"/> | |
| Replace damaged components | <input checked="" type="checkbox"/> | |

= May be carried out by a specialist company or the end user

= **Must** be carried out by a specialist company

13.1 Maintenance intervals



ATTENTION

Failure to adhere to maintenance intervals may cause property damage.

The maintenance interval for all tasks relating to the hardware components is **annually** at the least. In hospitals, schools and hotels, the maintenance interval is **six-monthly**.

Regular maintenance is necessary in order to maintain the proper and smooth-running operation of the hardware and to prevent premature wear or even defects.

- ▶ Determine and adhere to the appropriate maintenance interval in accordance with the ambient conditions.

13.2 Cleaning



ATTENTION

Using incorrect cleaning agents and sealing compounds may cause property damage.

Cleaning agents and sealing compounds may damage the surfaces of components and gaskets.

- ▶ Do not use aggressive or flammable liquids, acidic cleaners or abrasive cleaners.
- ▶ Only use mild, pH-neutral cleaning agents that have been diluted.
- ▶ Apply a thin protective film to the components, for example using a cloth soaked in oil.
- ▶ Avoid aggressive vapours (e.g. produced by formic acid, acetic acid, ammonia, amine compounds, ammonia compounds, aldehyde, carbolic acid, chlorine, tannic acid) around the element.
- ▶ Do not use any acetic acid-crosslinking or acid-crosslinking sealing compounds or those with the aforementioned constituents as both direct contact with the sealing compound and its fumes can corrode the surface of the components.

Cleaning the hardware

- ▶ Clean deposits and contaminants off the hardware using a soft cloth.
- ▶ Lubricate movable parts and locking points after cleaning. → 13.3 "Care" from page 246
- ▶ Apply a thin protective film to the hardware, for example using a cloth soaked in oil.

13.3 Care



ATTENTION

Using incorrect lubricants may cause property damage.

Substandard lubricants can prevent the hardware from working properly.

- ▶ Use high-quality lubricants.
- ▶ Only use resin-free and acid-free lubricants.
- ▶ Use appropriate lubricant in more challenging climatic conditions. Note the manufacturer specifications.



ATTENTION

Cleaning agents and lubricants may pollute the environment.

Leaking or excess cleaning agents and lubricants may pollute the environment.

- ▶ Remove any leaking or excess cleaning agents and lubricants.
- ▶ Dispose of cleaning agents and lubricants separately and properly.
- ▶ Observe the applicable directives and national laws.

Ease of movement can be improved by lubricating or adjusting the hardware. All functional hardware components must be lubricated on a regular basis.

Recommended lubricants

- Roto NX / NT grease



INFO

The figure displays the positioning of potential lubrication points. The figure does not necessarily match the installed hardware. The quantity of lubrication points varies depending on the size and design of the element.



13.3.1 Roto Patio Inowa

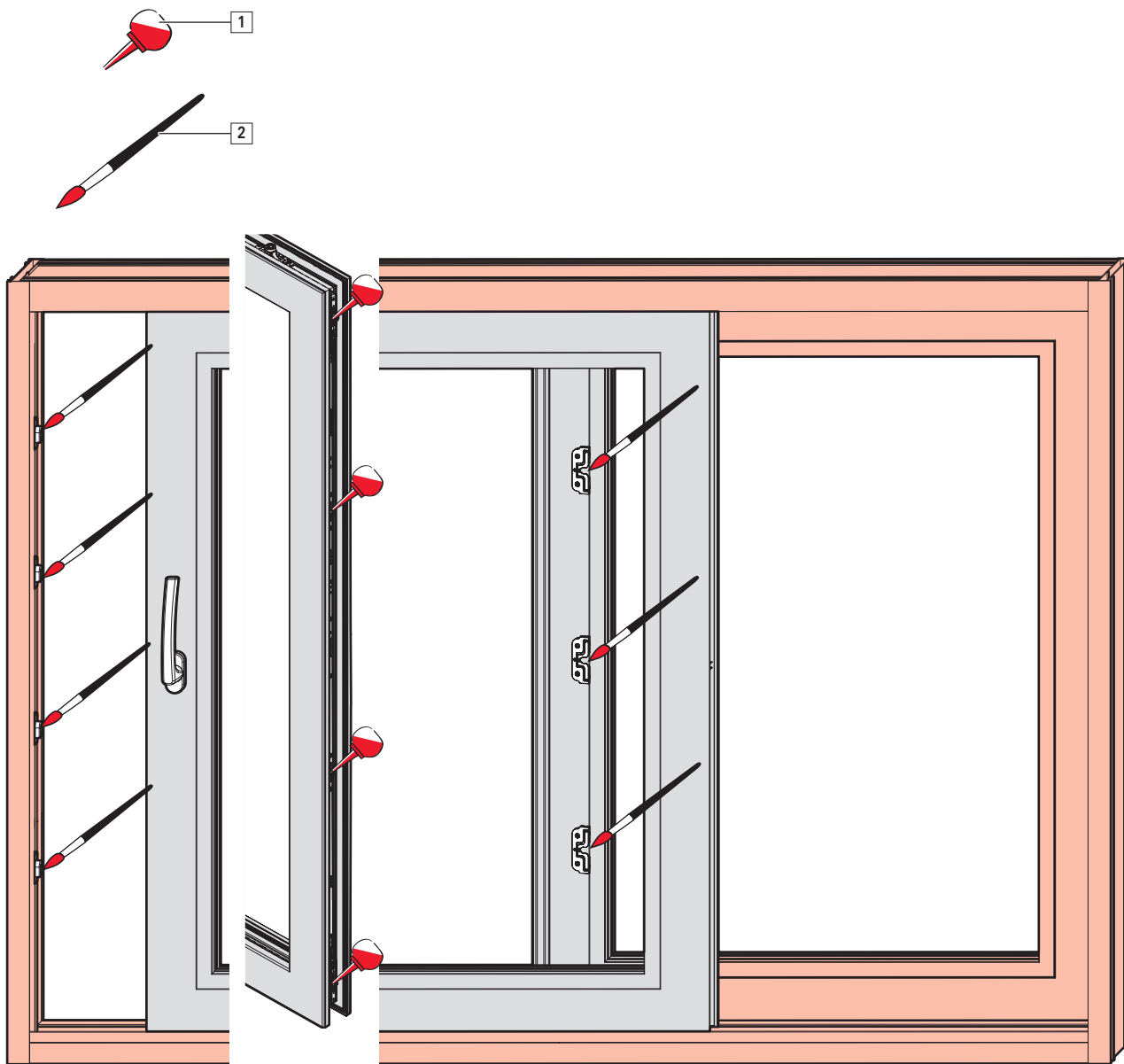

- [1] Lubricant
- [2] Grease

13.4 Performance test



DANGER

Risk of death caused a defective roller unit / damaged roller track!

A defective roller unit (which can be identified from scraping noises when moving the leaf) or a damaged roller track may cause the leaf to fall out.

1. If the leaf is stiff or does not slide evenly, have it inspected by a specialist company.
2. If the roller track is visibly damaged, have the elements inspected by a specialist company.
3. If necessary, have defective / damaged components replaced.



WARNING

Improper repair work may pose a risk of death!

Improper maintenance may prevent the element from working properly and make it less safe to use.

- ▶ Always have repairs performed by a specialist company.

Check for proper operation:

- ▶ Inspect hardware components for damage, deformation and a secure fit.
- ▶ Check that the elements run smoothly by opening and closing them.
- ▶ Check the element gaskets for elasticity and fit.
- ▶ Check closed elements to ensure that they are leakproof.
- ▶ Locking and unlocking torque max. 10 Nm. The check can be performed using a torque wrench.

Have malfunctions remedied by a specialist company.

13.5 Repair



WARNING

Improper repair work may pose a risk of death!

Improper maintenance may prevent the element from working properly and make it less safe to use.

- ▶ Always have repairs performed by a specialist company.



ATTENTION

Improper screw fixings may cause property damage.

Loose or faulty screws can prevent the hardware from working properly.

- ▶ Check that the individual screws are secure and seated correctly.
- ▶ Tighten or replace loose or faulty screws.
- ▶ Use only the suggested screws.

Repair work includes replacing and repairing components and is only necessary if components have become damaged after wear or as a result of external circumstances. The hardware must be secured reliably in order to ensure that the element works properly and is safe to use.

The following tasks must only be performed by a specialist company:

- All adjustment work on the hardware,
- Replacing hardware or hardware components,
- Installing and removing windows, doors or balcony doors

The specialist company must observe the following:

- Perform the necessary repair work properly, according to generally recognised engineering practice and in accordance with the applicable regulations.
- Do not perform makeshift repairs on worn or damaged components.
- Only use original or approved spare parts for repairs.



14 Dismantling



WARNING

Improper dismantling may pose a risk of death!

The sash may fall during dismantling.

- ▶ Secure the sash to prevent it from falling, e.g. by using two people.
- ▶ Always have dismantling work performed by a specialist company.



CAUTION

Physical strain may cause injury and damage to health.

Carrying and lifting heavy loads for extended periods leads to physical injury in the long term.

- ▶ When carrying or lifting loads, maintain an ergonomically correct posture. The maximum permissible load is 25 kg for men and 10 kg for women.



INFO

Unless otherwise stated, dismantling is performed in reverse order to installation.

14.1 Unhinging the sash

Version with split guide track

1. Remove the guide track in the fixed glazing area.

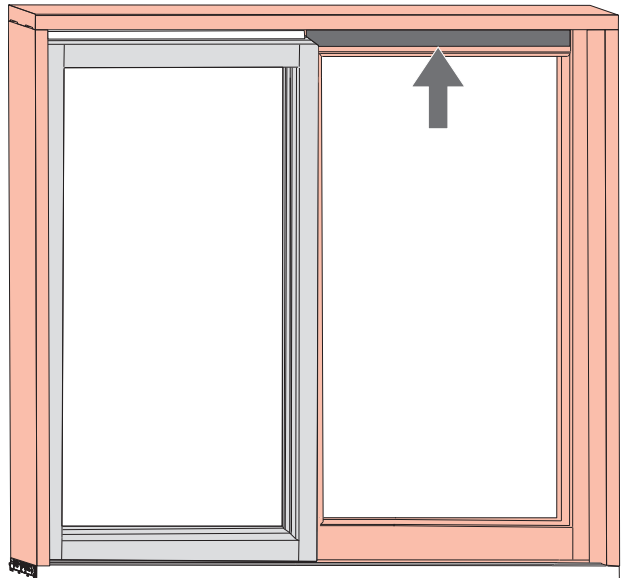

2. Move the handle to the open sliding position



Dismantling

Unhinging the sash

3. Push the sash onto the roller track in front of the fixed glazing area in a controlled manner until the control units are exposed.

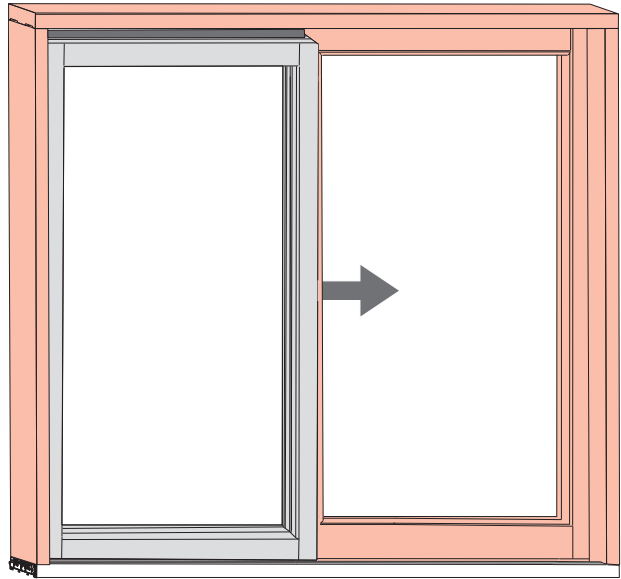

4. Remove the sash parallel to the frame.

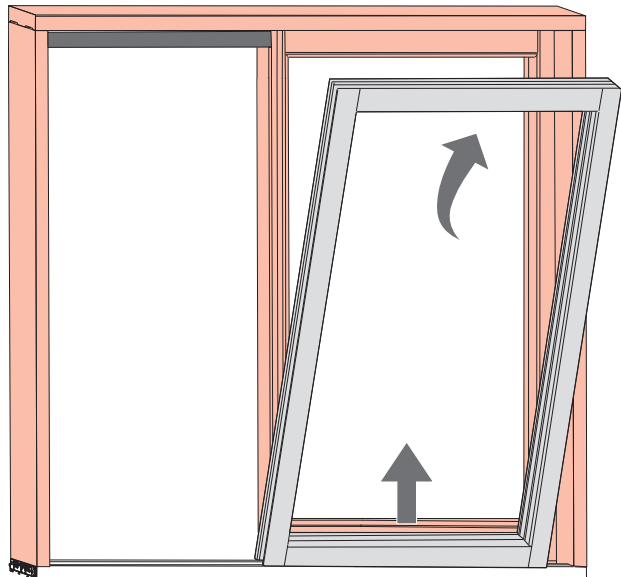

Version with continuous guide track

1. Move the handle to the open sliding position





2. Lift the sash and tilt it outwards at the bottom.
Lower the sash in a controlled manner until the control units are exposed.

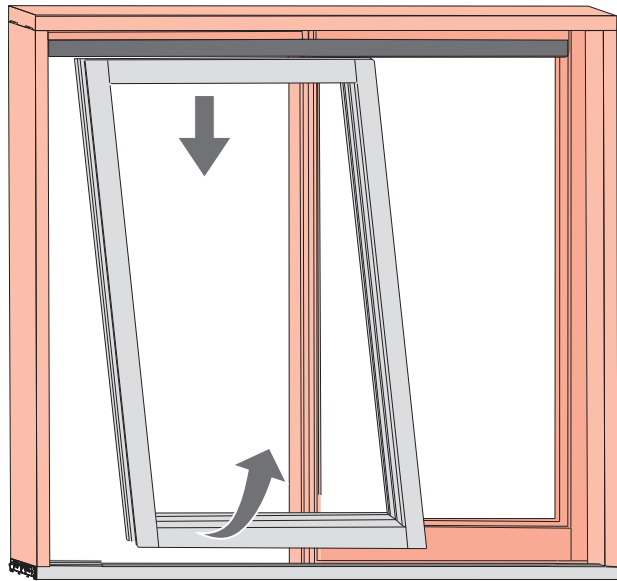

3. Remove the sash parallel to the frame.

14.2 Hardware components

Removing hardware components

1. Undo all screw connections.
2. Remove the hardware components.
3. Dispose of the hardware components properly.

15 Transport

15.1 Transporting elements and hardware



DANGER

Improper transport poses a risk of death!

Improper procedures for transporting, loading or unloading elements may cause serious injuries and glass breakage as a result of the elements swinging open, falling or becoming overloaded.

- ▶ Note the applicable accident prevention regulations.
- ▶ Note force application points and reaction forces.
- ▶ Prevent the sash from opening uncontrollably.
- ▶ Avoid jerky movements.
- ▶ Use suitable transportation means and protective devices.
- ▶ Watch out for protruding components.
- ▶ Transport heavy loads with two people and use suitable transportation means (such as an industrial truck).



CAUTION

Trapped limbs may result in injuries.

The transported goods can skid, open, close or fall during transportation tasks. This can result in limbs being trapped and seriously injured.

- ▶ Never reach near the scissor stays.
- ▶ Close the sash after installation and secure it in place for transport.
- ▶ Wear safety gloves and protective footwear.



CAUTION

Physical strain may cause injury and damage to health.

Carrying and lifting heavy loads for extended periods leads to physical injury in the long term.

- ▶ When carrying or lifting loads, maintain an ergonomically correct posture. The maximum permissible load is 25 kg for men and 10 kg for women.

Hardware is supplied to the specialist company as complete sets. The components are packaged accordingly for each scope of delivery. The instructions for safely transporting the hardware are described below.

Observe the following basic instructions when transporting hardware:

- ▶ Transport larger scopes of delivery using appropriate transportation means (such as industrial trucks).
- ▶ Note the transport weight in order to select appropriate transportation means.
- ▶ Ensure that the transport process is careful and appropriate for the material and that components are protected against dirt during transport.
- ▶ Immediately check the delivery for completeness and transport damage on receipt.



INFO

Submit a complaint about any defects as soon as they are identified. Claims for damages may only be made within the reclamation period.

Use the following transportation means for support when transporting, loading and unloading larger scopes of delivery:

- Industrial trucks, e.g. forklifts, telescopic handlers, pallet trucks
- Lifting equipment, e.g. transport nets, carry straps, round slings
- Protective devices, e.g. edge protection, spacer blocks



INFO

Industrial trucks and lifting devices may only be operated by qualified persons.



INFO

Lifting equipment and protective devices may only be used if they are in full working order.

15.2 Storing the hardware

Store all hardware components as follows until they are installed:

- Dry and protected
- On a level surface
- Protected against sunlight

16 Disposal



ATTENTION

Incorrect disposal may pollute the environment.

Pieces of hardware are raw materials.

- ▶ Dispose of hardware for environmentally friendly material reutilisation as mixed scrap.

16.1 Disposing of packaging

The hardware is supplied as complete sets together with the packaging. Once unpacked, the installation company or builder is responsible for disposing of the packaging properly. The packaging materials are produced in accordance with current environmental protection standards. The materials can be recycled separately.

Follow the basic instructions below for the proper disposal of packaging:

- ▶ Do not dispose of packaging in household waste.
- ▶ Hand over packaging at local waste collection points or recycling centres.
- ▶ Observe the national regulations on the disposal of recyclable materials.
- ▶ Contact the local authorities if necessary.

16.2 Disposing of hardware

Once the hardware is finished with, the end user or builder is responsible for properly disposing of the windows, doors or balcony doors and the hardware, including any accessories. Hardware is produced in accordance with current environmental protection standards. The materials can be recycled separately.

Follow the basic instructions below for the proper disposal of hardware:

- ▶ Observe the information and specifications for disposal contained in the other applicable documents.
- ▶ Separate hardware components from windows, doors or balcony doors.
- ▶ Do not dispose of hardware in household waste.
- ▶ Hand over hardware at local waste collection points or recycling centres.
- ▶ Observe the national regulations on the disposal of recyclable materials.
- ▶ Contact the local authorities if necessary.



Roto Frank
Fenster- und Türtechnologie GmbH

Wilhelm-Frank-Platz 1
70771 Leinfelden-Echterdingen
Germany

Phone +49 (0) 711 7598 0
Fax +49 (0) 711 7598 253
info@roto-frank.com

www.roto-frank.com

From a single source: Optimum hardware systems to meet all challenges

- Roto Window** | Hardware systems for windows and balcony doors
- Roto Sliding** | Hardware systems for large sliding windows and doors
- Roto Door** | Matching hardware technology everything about doors
- Roto Equipment** | Additional technology for windows and doors